



# City of Chicago



Or2023-181

Office of the City Clerk

## Document Tracking Sheet

<b>Meeting Date:</b>	5/24/2023
<b>Sponsor(s):</b>	Burnett (27)
<b>Type:</b>	Order
<b>Title:</b>	Issuance of permits for sign(s)/signboard(s) at 1730 W. Fullerton Ave. - Permit No. 101012401
<b>Committee(s) Assignment:</b>	Committee on Zoning, Landmarks and Building Standards

CITY COUNCIL  
COMMITTEE ON ZONING, LANDMARKS AND BUILDING STANDARDS

COUNCIL ORDER

RE: Approval of sign over 100 square feet in area or over 24 feet above grade

ORDERED, that the City Council hereby approves the following sign application submitted by:

Level Nails Bar

Applicant\*:

(\* The Applicant is the owner of the real property or the business tenant of the real property. Do not list the sign contractor, sign erector, sign company or advertising entity in the above space.)

This Order approves the following sign in accordance with Municipal Code of Chicago Section 13-20-680:

Address of Sign: 1730 W Fullerton Chicago, IL 60614

Zoning District: PD437

DOB Sign Permit Application #: 101012401

Sign Details:

1. On-premise  OR Off-premise

2. Static sign  OR Dynamic-image display sign

3. Number of sign faces 1

4. Projecting over the public way No (Yes or No) If yes, Public Way Use #: \_\_\_\_\_

5. Dimensions: Length 34 feet \_\_\_\_\_ inches Height 3 feet 11 inches

Total square feet in area: 133 feet \_\_\_\_\_ inches

6. Height above grade: 13 feet \_\_\_\_\_ inches

7. Elevation (side of building or lot where the sign will be erected): N

8. Name of Sign Contractor/Erector: Monsibic Inc.

To be legal, such sign shall comply with all provisions of Title 17 of the Chicago Municipal Code ("Zoning Ordinance") and all other provisions of the Municipal Code governing the permitting, construction and maintenance and removal of signs and sign structures. Failure of the applicant and the applicant's successors to comply shall be grounds for invalidation or revocation of the sign permit.

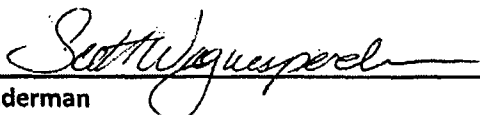
  
Alderman

  
Ward

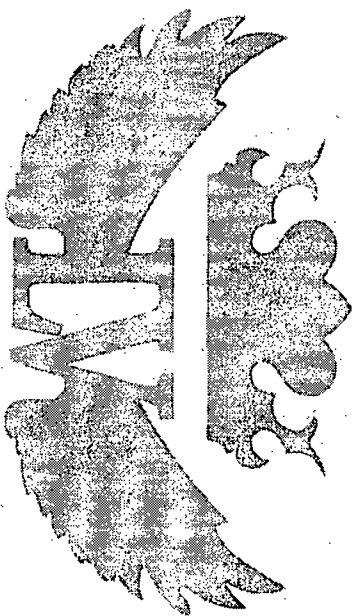

# LEVEL NAILS BAR

1730 W. Fullerton, suites 27 & 28  
Chicago, IL 60614

**PRESENTED BY: KEVIN WONG**



E365547

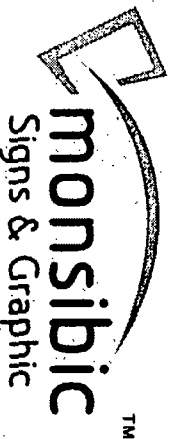

INTERNATIONAL SIGN ASSOCIATION



Tel: 773-847-2828 Fax 773-847-0088  
927 W 35th St,  
Chicago, IL 60608  
U.S.A

Sign Location

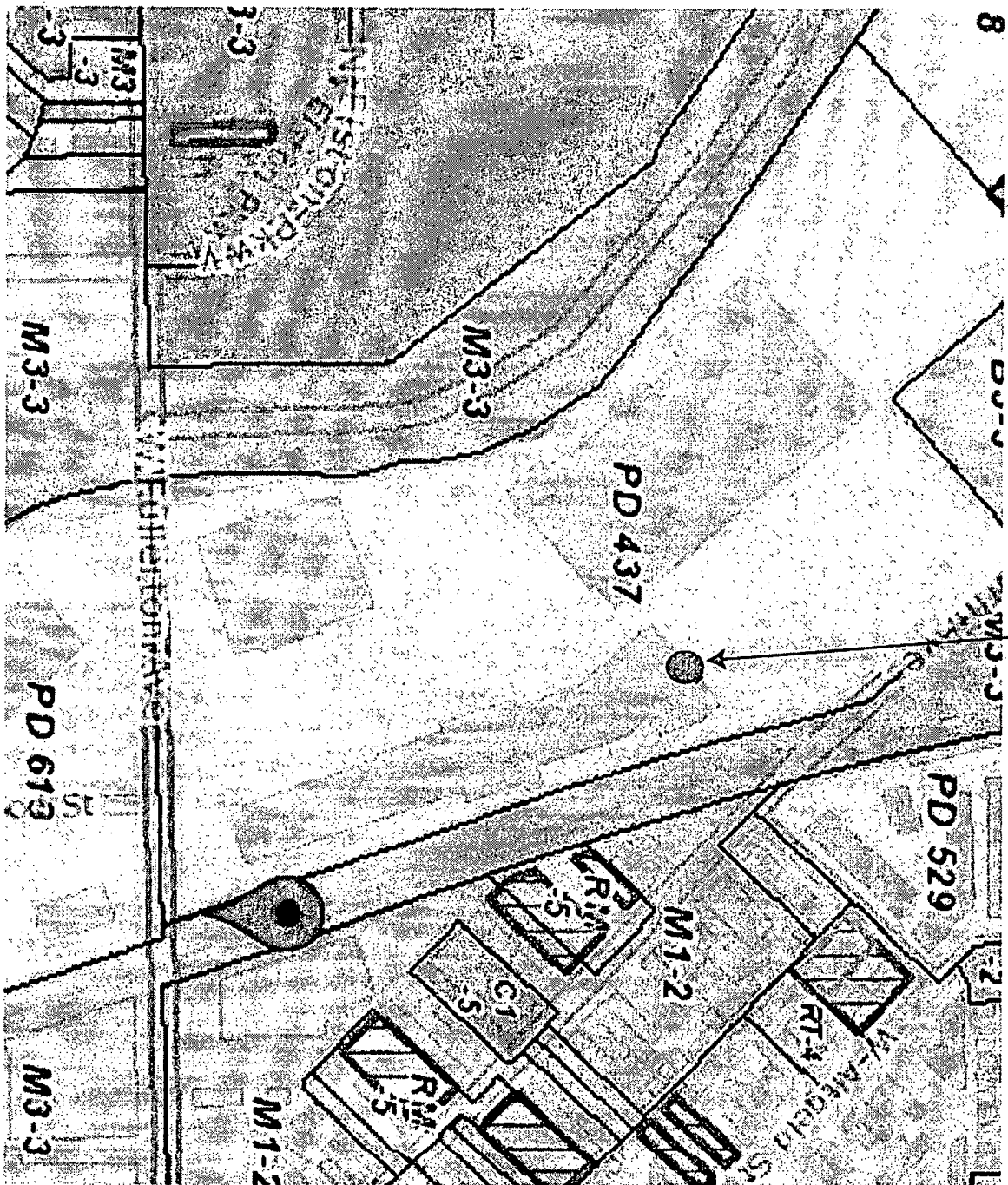

# SIGN 1 : SITE VIEW

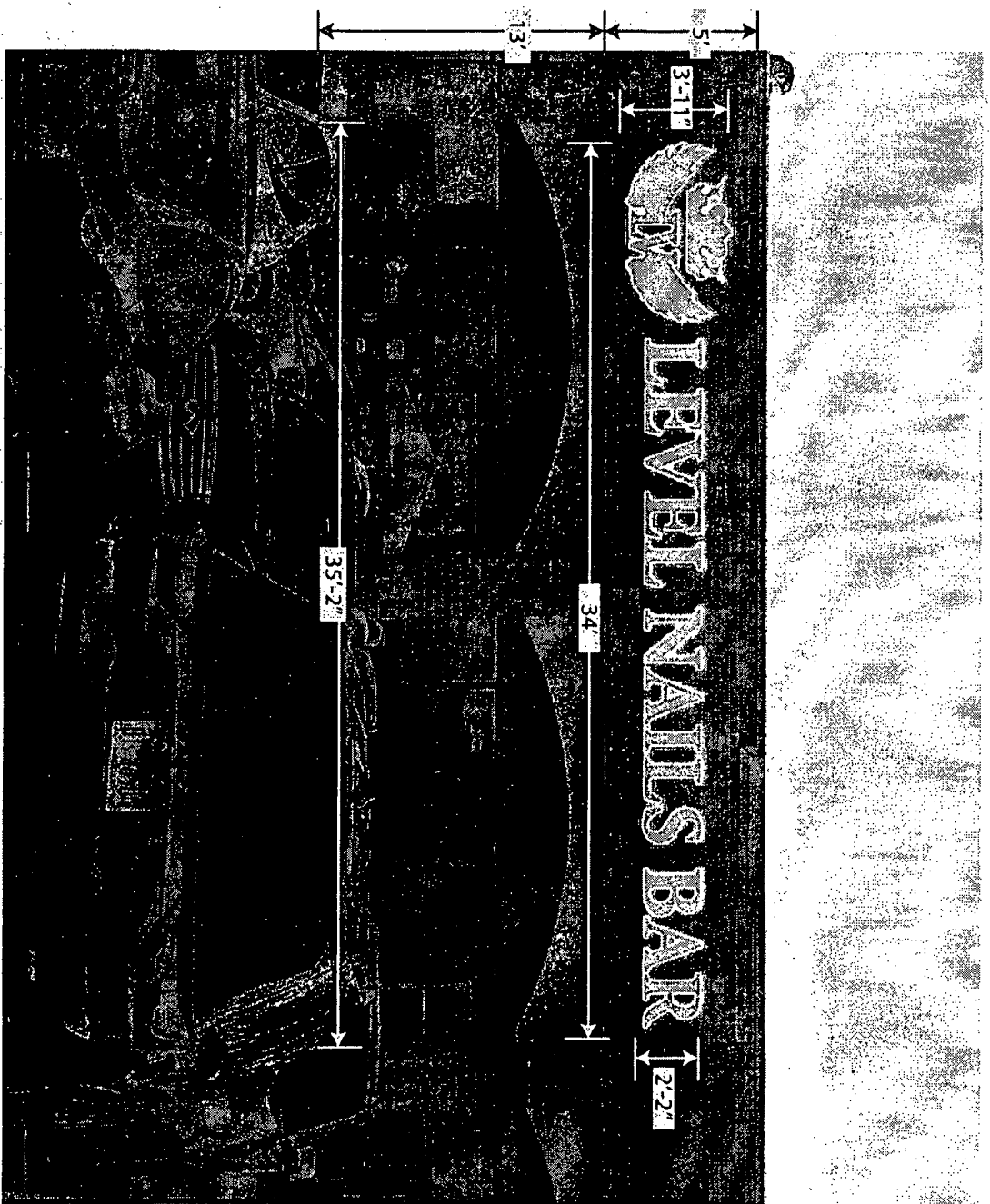

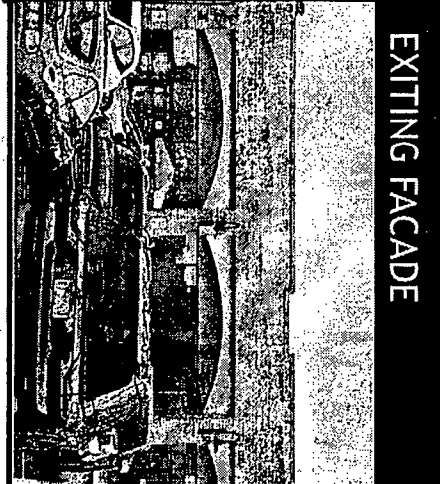

Sample:  
Backlit Gold Channel Letter

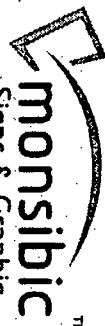

EXITING FACADE

**NOTE:** Elevation drawings are for customer approval only; drawings are not to be used as any installation guide, all dimensions must be verified before installation.  
Color output may not be exact when viewing or printing this drawing. All colors used are PMS or the closest CMYK

 <b>monsibic</b> <sup>TM</sup> Signs & Graphic T: 773-847-2828 927 W 35th St., Chicago, IL 60608	<b>Client Name:</b> LEVEL NAILS BAR	<b>Start Date:</b> 03/15/2023	..... <b>Client Approval</b>	<b>Sales Rep:</b> kw
	<b>Location:</b> 1730 W. Fullerton Ave suites 27 & 28 Chicago, IL 60614	<b>Last Revision:</b>	..... <b>Landlord Approval</b>	<b>Designer:</b> 
<b>Job#:</b> .....	<b>Job#:</b> .....	..... <b>Landlord Approval</b>		
<b>Drawing#:</b> .....	<b>Drawing#:</b> .....			
<b>Page:</b> .....				

© COPYRIGHT 2018, BY MONSIBICI INC. - ALL DESIGNS PRESENTED ARE THE SOLE PROPERTY OF MONSIBICI INC AND MAY NOT BE REPRODUCED IN PART OR WHOLE WITHOUT WRITTEN PERMISSION FROM MONSIBICI INC.

# SIGN 1: INTERNALLY ILLUMINATED CHANNEL LETTER

Back Lit, Channel Letters w/ LED, Flush Mounted

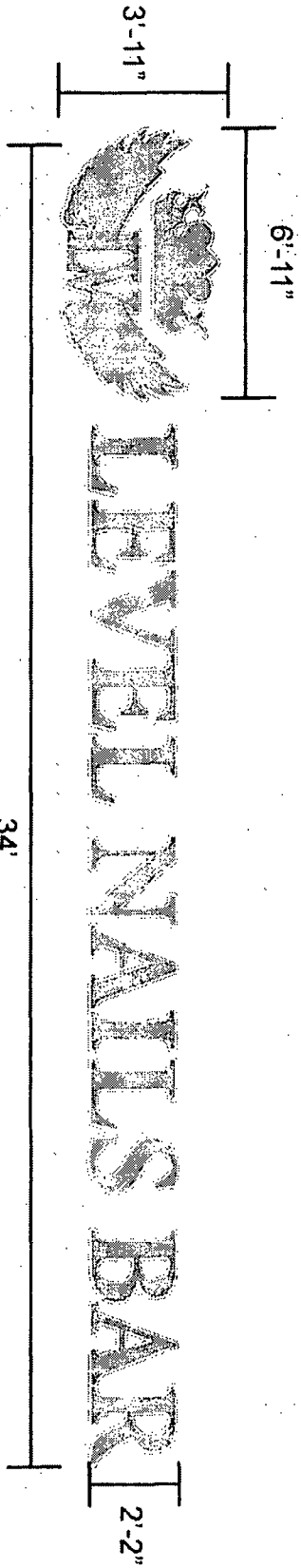

34

## SPECIFICATIONS

Area:	47'H x 408'W	TO BE CONFIRM
Total Sq.Ft.:	133,17 R²	
Returns:	Gold	
Trimcap:	Gold	
Illumination:	White LED	
Face:	Gold	
Raceway:	N/A	

## BACK-LIT CHANNEL LETTER - TYPICAL SECTION - FLUSH MOUNTED

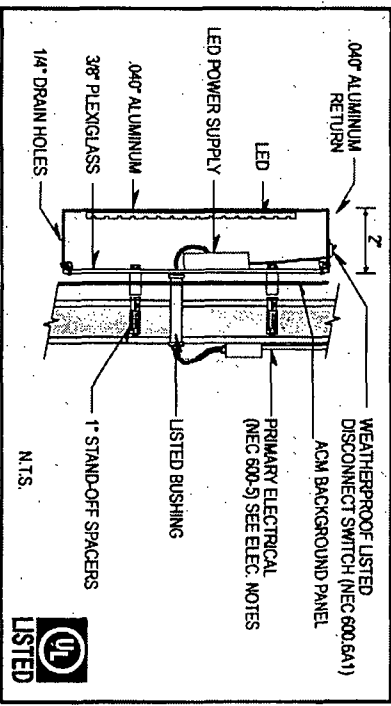

**Note:**  
Color output may not be exact when viewing or printing this drawing. All colors used are PMS or the closest CMYK.

**137 Grounding and Bonding Statement**  
This sign is intended to be installed in accordance with the requirements of Article 600 of the National Electrical Code and/or other applicable codes. This includes proper grounding and bonding of the sign.

**ELECTRICAL NOTES**  
1. Each sign must have a ground wire.  
2. Grounding must be done by a licensed electrician.  
3. Grounding must be done by a licensed electrician.  
4. Grounding must be done by a licensed electrician.  
5. Grounding must be done by a licensed electrician.

**LISTED**

**NOTE:** Elevation drawings are for customer approval only, drawings are not to be used as any installation guide, all dimensions must be verified before installation. Color output may not be exact when viewing or printing this drawing. All colors used are PMS or the closest CMYK

<p>monsibic™ Signs &amp; Graphic T: 773-847-2828 927 W 35th St., Chicago, IL 60608</p>	<p><b>Client Name:</b> LEVEL NAILS BAR</p> <p><b>Location:</b> 1730 W. Fullerton Ave. suite 27 &amp; 28 Chicago, IL 60614</p>	<p><b>Start Date:</b> 03/15/2023</p> <p><b>Last Revision:</b></p> <p><b>Job#:</b></p> <p><b>Drawing#:</b></p> <p><b>Page:</b></p>	<p>Client Approval</p> <p>Landlord Approval</p>	<p><b>Sales Rep:</b> kw</p> <p><b>Designer:</b> Simon L.</p> <p></p>
	<p>© COPYRIGHT 2019 BY MONSIBIC INC. - ALL DESIGNS PRESENTED ARE THE SOLE PROPERTY OF MONSIBIC INC. AND MAY NOT BE REPRODUCED IN PART OR WHOLE WITHOUT WRITTEN PERMISSION FROM MONSIBIC INC.</p>			

# EXISTING SIGNS

80 + 31.5 + 37.45 + 64 + 53.66 + 16 + 99 + 150.5 + 72 + 39 + 65 + 30.66 + 29.16 + 24 + 33.33 + 53.16 = **878.42 sq. ft.**

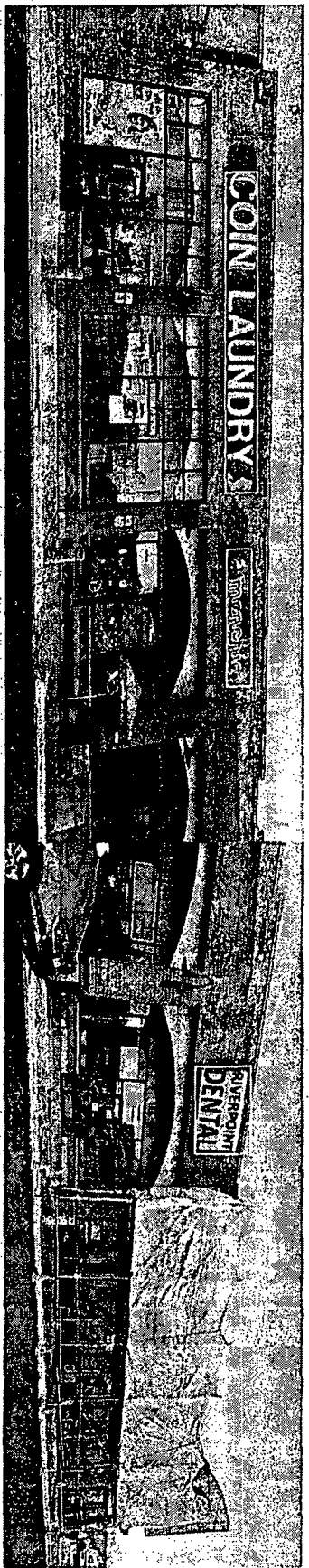

32"H x 360"W

28"H x 162"W

58"H x 93"W

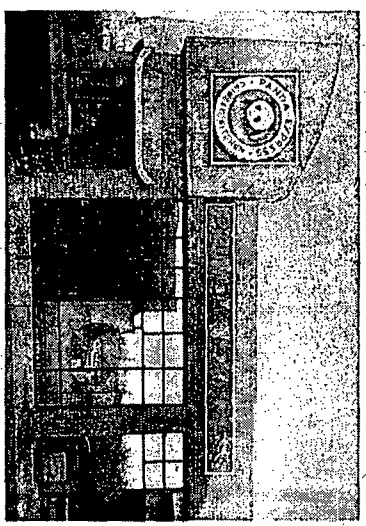

96"H x 96"W

28"H x 276"W

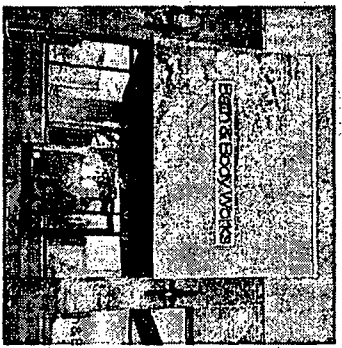

16"H x 144"W

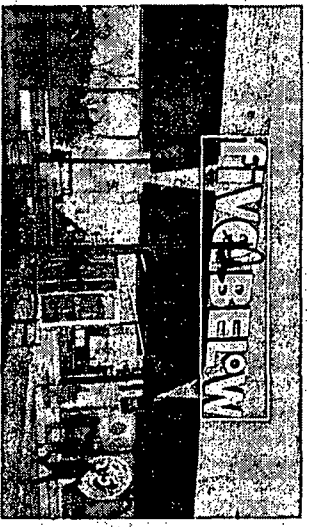

44"H x 324"W



86"H x 252"W

32"H x 324"W

36"H x 156"W

30"H x 312"W

32"H x 138"W

20"H x 210"W

24"H x 144"W

40"H x 120"W

44"H x 174"W

