



City of Chicago



O2019-7705

Office of the City Clerk

Document Tracking Sheet

Meeting Date:	9/18/2019
Sponsor(s):	Reilly (42)
Type:	Ordinance
Title:	Grant(s) of privilege in public way for Francois Frankie
Committee(s) Assignment:	Committee on Transportation and Public Way

ORDINANCE
FRANCOIS FRANKIE
Acct. No. 456415 - 1
Permit No. 1141358

Be It Ordained by the City Council of the City of Chicago:

SECTION 1. Permission and authority are hereby given and granted to FRANCOIS FRANKIE, upon the terms and subject to the conditions of this ordinance to maintain and use two (2) sign(s) projecting over the public right-of-way attached to its premises known as 222 W. Randolph St..

Said sign structure(s) measures as follows; along W. Randolph Street:

One (1) at three point five eight (3.58) feet in length, three point five (3.5) feet in height and fourteen (14) feet above grade level.

Said sign structure(s) measures as follows; along W. Randolph Street:

One (1) at twenty-two point two five (22.25) feet in length, three point five (3.5) feet in height and fourteen (14) feet above grade level.

The location of said privilege shall be as shown on prints kept on file with the Department of Business Affairs and Consumer Protection and the Office of the City Clerk.

Said privilege shall be constructed in accordance with plans and specifications approved by the Department of Transportation (Division of Project Development) and Zoning Department - Signs.

This grant of privilege in the public way shall be subject to the provisions of Section 10-28-015 and all other required provisions of the Municipal Code of Chicago.

The grantee shall pay to the City of Chicago as compensation for the privilege #1141358 herein granted the sum of four hundred (\$400.00) per annum in advance.

A 25% penalty will be added for payments received after due date.

The permit holder agrees to hold the City of Chicago harmless for any damage, relocation or replacement costs associated with damage, relocation or removal of private property caused by the City performing work in the public way.

Authority herein given and granted for a period of five (5) years from and after Date of Passage.

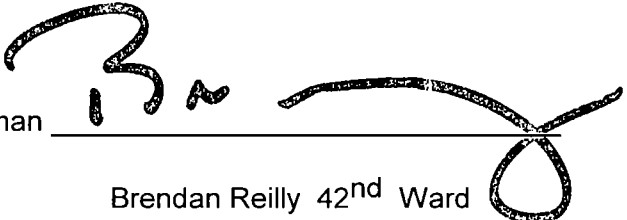
Alderman 
Brendan Reilly 42nd Ward

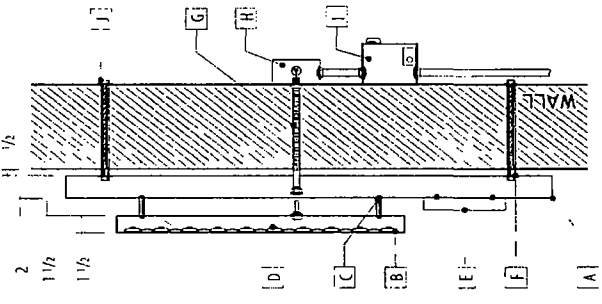

ILLUMINATED CABINET SIGN

- A 125 aluminum cabinet backer panel painted MP52215
 - B 125 Halo illuminated Channel Letters painted white
 - C 1 1/2 standoffs mounted to backer panel
 - D White LED illumination
 - E 1 thick white acrylic letters stud mounted to backer panel
 - F 1/2 standoffs between backer panel and wall
 - G UL listed conduit as per code
 - H UL listed housing (splice point if needed)
 - I Power supply
 - J 5/16 (min) all thread thru bolts w/ 1/2 spacers
- Sign to have illumination dimmer capability

MP52215 BORON GREY (METALLIC)



All electrical to be in accordance with UL, the NEC and local code



CORPORATE IDENTIFICATION SOLUTIONS

CUSTOMER
Francois Frankie's
SITE NUMBER
N/A

LOCATION
Chicago IL
ACCOUNT REP
Mike Shely

DRAWN BY
MH
DATE
06/20/19

REVISION
11
SCALE
N15

CORPORATE ID SOLUTIONS
5563 N Elston Ave
Chicago, IL 60630
P 773 763 9600 | F 773 763 9606
www.corporateidsolutions.com

CUSTOMER ACCEPTANCE
THIS DRAWING IS THE PROPERTY OF CORPORATE IDENTIFICATION SOLUTIONS INC. IT IS TO BE USED ONLY FOR THE PROJECT AND SITE SPECIFICALLY IDENTIFIED. IT IS TO BE RETURNED TO THE COMPANY AND SUPPLIES OF PEOPLE. IT IS NOT TO BE REPRODUCED OR TRANSMITTED IN ANY FORM OR BY ANY MEANS, ELECTRONIC OR MECHANICAL, INCLUDING PHOTOCOPYING, RECORDING, OR BY ANY INFORMATION STORAGE AND RETRIEVAL SYSTEM. WITHOUT THE WRITTEN CONSENT OF CORPORATE IDENTIFICATION SOLUTIONS INC. SIGNATURE _____ DATE _____

77 9 SQFT