



# City of Chicago



O2015-2857

Office of the City Clerk

## Document Tracking Sheet

<b>Meeting Date:</b>	4/15/2015
<b>Sponsor(s):</b>	Cardenas (12)
<b>Type:</b>	Ordinance
<b>Title:</b>	Grant(s) of privilege in public way for Cocula Restaurant
<b>Committee(s) Assignment:</b>	Committee on Transportation and Public Way

ORDINANCE  
COCULA RESTAURANT  
Acct. No. 85500 - 2  
Permit No. 1116495

*Be It Ordained by the City Council of the City of Chicago:*

SECTION 1. Permission and authority are hereby given and granted to COCULA RESTAURANT, upon the terms and subject to the conditions of this ordinance to maintain and use one (1) sign(s) projecting over the public right-of-way attached to its premises known as 2801 W. Cermak Rd..

Said sign structure(s) measures as follows; along W. Cermak:  
One (1) at six (6) feet in length, eight (8) feet in height and thirteen (13) feet above grade level.

The location of said privilege shall be as shown on prints kept on file with the Department of Business Affairs and Consumer Protection and the Office of the City Clerk.

Said privilege shall be constructed in accordance with plans and specifications approved by the Department of Transportation (Division of Project Development) and Zoning Department - Signs.

This grant of privilege in the public way shall be subject to the provisions of Section 10-28-015 and all other required provisions of the Municipal Code of Chicago.

The grantee shall pay to the City of Chicago as compensation for the privilege #1116495 herein granted the sum of three hundred (\$300.00) per annum in advance.

A 25% penalty will be added for payments received after due date.

The permit holder agrees to hold the City of Chicago harmless for any damage, relocation or replacement costs associated with damage, relocation or removal of private property caused by the City performing work in the public way.

Authority herein given and granted for a period of five (5) years from and after Date of Passage.

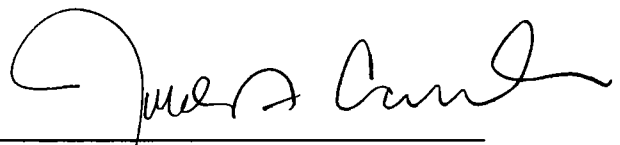
Alderman   
George Cardenas 12<sup>th</sup> Ward

# Internally Illuminated Box Sign with Dynamic Display

## MOUNTED ON ONE FRAME

### CROSS SECTION DETAIL

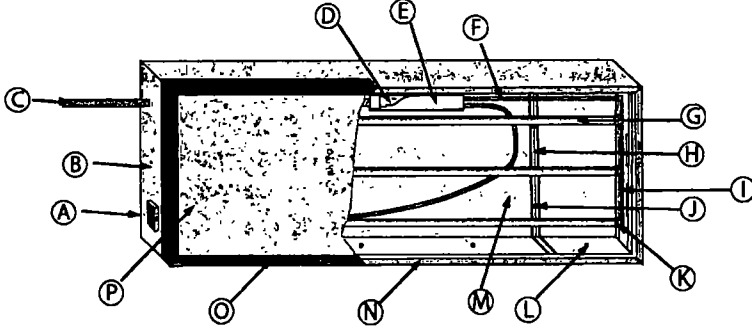

A	listed disconnect switch
B	Aluminum slide
C	primary electrical source
D	H.O. Ballast
E	Ballast box
F	1/2" greenfield
G	Flourescent Lamp
H	1 1/2"x 1 1/2"x 3/16" U Steel Angle
I	Wire way box
J	Installation Holes
K	Socket
L	Weep Holes
M	.060 Sheet Metal Back
N	1 1/2" x 1 1/2" x 1/8" Steel Angle
O	2" x 2" Aluminum Retainers
P	3/16" White Lexon

All electrical to be UL Listed

### LED Dynamic Display

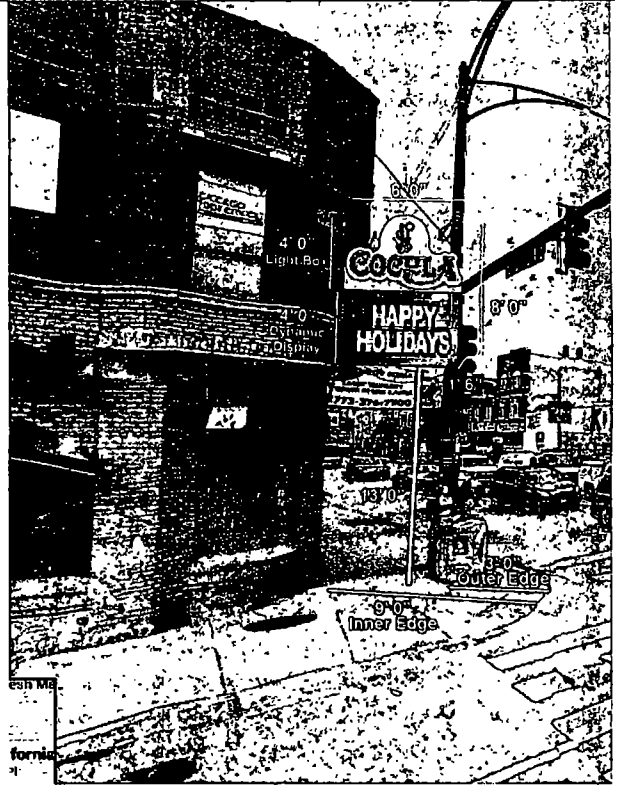

NOTE: Photo for representational purposes only. Signs are not to scale and may appear larger or smaller than shown.

#### Sign Erector:

**PRO IMAGE**  
 2006 W. Chicago, Ave.  
 Chicago, IL 60622  
 Tel. 773 292 1111  
 Fax. 773 645 4169

#### Location

North Elevation

#### Address

2801 W. Cermak Rd.  
 Chicago, IL. 60623

Date: 1-9-2015

#### Description

- NEW PROJECTING BOX ILLUMINATE SIGN & Dynamic
- WALL MOUNTED.
- VINYL LETTERING GREEN.
- 3/16 WHITE LEXON.
- INTERNALLY ILLUMINATE 8 & 2 FT. FLOURESCENT LAMPS
- READS: COQUILA + Dynamic Display

Client **COCULA RESTAURANT**



**04/15/2015**

**Alderman George Cardenas**  
Ward # 12  
City of Chicago  
City Hall, Room 203  
121 North LaSalle Street  
Chicago, Illinois 60602

Re: An ordinance to use and maintain a portion of the public right-of-way for **one (1) sign(s)** for **COCULA RESTAURANT**, adjacent to the premises known as **2801 W. Cermak Rd.**.

Dear **Alderman George Cardenas**:

The applicant referenced above has requested the use of the public right-of-way for a **sign(s)**. An ordinance has been prepared by the Department of Business Affairs and Consumer Protection – Small Business Center - Public Way Use Unit for presentation to the City Council. Because this request was made for properties located in your ward, as approved by you as per the attached, I respectfully request that you introduce the attached ordinance at the next City Council meeting.

If you have any questions regarding this ordinance, please contact Anthony Bertuca at (312) 744-5506.

**Department of Business Affairs and Consumer Protection**