



# City of Chicago



O2016-5086

Office of the City Clerk

## Document Tracking Sheet

<b>Meeting Date:</b>	6/22/2016
<b>Sponsor(s):</b>	Hairston (5)
<b>Type:</b>	Ordinance
<b>Title:</b>	Grant(s) of privilege in public way for Revival, The
<b>Committee(s) Assignment:</b>	Committee on Transportation and Public Way

ORDINANCE  
THE REVIVAL  
Acct. No. 401021 - 1  
Permit No. 1123038

*Be It Ordained by the City Council of the City of Chicago:*

SECTION 1. Permission and authority are hereby given and granted to THE REVIVAL, upon the terms and subject to the conditions of this ordinance to maintain and use two (2) sign(s) projecting over the public right-of-way attached to its premises known as 1160 E. 55th St..

Said sign structure(s) measures as follows; along E. 55th Street:

One (1) at thirteen point nine two (13.92) feet in length, two point nine two (2.92) feet in height and fourteen point three three (14.33) feet above grade level.

One (1) at two point five (2.5) feet in length, one point one seven (1.17) feet in height and nine (9) feet above grade level.

The location of said privilege shall be as shown on prints kept on file with the Department of Business Affairs and Consumer Protection and the Office of the City Clerk.

Said privilege shall be constructed in accordance with plans and specifications approved by the Department of Transportation (Division of Project Development) and Zoning Department - Signs.

This grant of privilege in the public way shall be subject to the provisions of Section 10-28-015 and all other required provisions of the Municipal Code of Chicago.

The grantee shall pay to the City of Chicago as compensation for the privilege #1123038 herein granted the sum of four hundred (\$400.00) per annum in advance.

A 25% penalty will be added for payments received after due date.

The permit holder agrees to hold the City of Chicago harmless for any damage, relocation or replacement costs associated with damage, relocation or removal of private property caused by the City performing work in the public way.

Authority herein given and granted for a period of five (5) years from and after Date of Passage.

Alderman

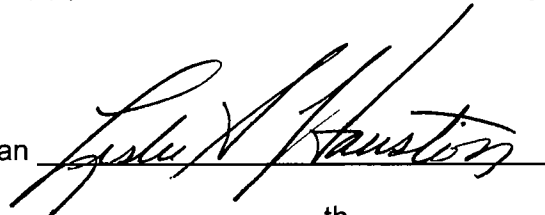
A handwritten signature in black ink, appearing to read "Leslie Hairston", written over a horizontal line.

Leslie Hairston 5<sup>th</sup> Ward

Sign 2

By signing the G. F. C. E. C. on this permit, I understand that I am accepting all aspects of this drawing. This includes artwork, specifications, dimensions, spacing, and all other requirements herein. I also understand that color reproduction on this permit are approximate and may not match a manufacturer's product exactly.

CUSTOMER: FA CEPT I C S G I A T U E DATE: IF REQUIRED: LENDOR 1 A DATE: PERMITS: G A T L R E DATE: I S G SALES: I T I A L S DATE:

### City of Chicago Permit Drawing

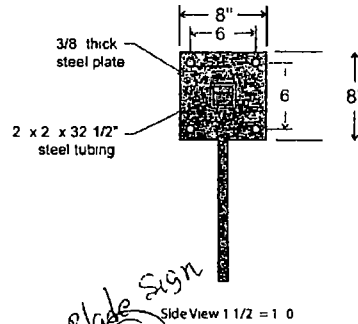
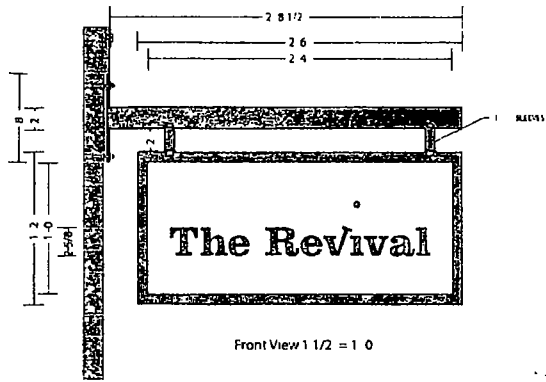

#69080	Landmark Sign Group
Sign Type:	Non-Illuminated Sign
Overall Size:	12 x 24
Square Footage:	295F
Approx Weight:	12 lb

**Combined Existing Tenant Signage**  
 Bergstein's NY Delicatessen 30 Square Feet  
 Woodlawn Tap 30 Square Feet  
 The Nile 15 Square Feet  
 Starbucks Coffee 60 Square Feet  
 Total = 135 Total Other Tenant sq Feet

- ▶ ONE DOUBLE FACE SIGN/ NON ILLUMINATED/ 1" ALUMINUM TUBE FRAME WITH .080" FACES/ EXT PAINTED/ 3/8" ALUMINUM PLATE WITH COPY WATER JET CUT OUT GLUED TO FACE/ FLAG MOUNT TO BRICK WITH MOUNTING PLATE
- MAIN FRAME AND FACES = MATTHEWS 41313SP DARK BRONZE
- 3/8" WATER JET CUT PANELS = HORIZONTAL BRUSHED with LOW GLOSS FINISH
- 2 MOUNTING TUBE & PLATE = MAP BLACK
- SLEEVES = MATTHEWS 41313SP DARK BRONZE

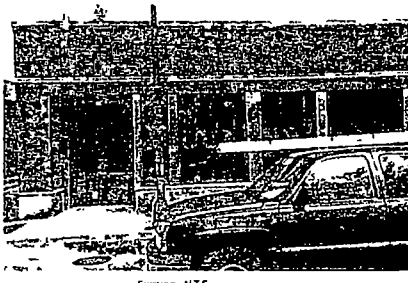

7424 Industrial Avenue  
 Chesterton, IL 60014  
 phone 219 762 9577  
 fax 219 762 4269  
 www.landmarkgroup.com

PRINT # 1  
**RB-22892-2**

**RANDY BENNETT**  
 LEO SALES REPRESENTATIVE

**03 23 16**  
 DATE

**THE REVIVAL THEATER**

CLIENT NAME  
**1160 E 55TH ST  
 CHICAGO IL**

SIGN LOCATION  
 SCALE 1 1/2" = 1'-0"

DRAWN BY: [Signature] SCALE

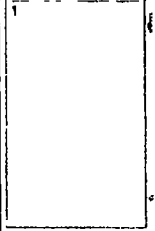

THIS DRAWING IS THE PROPERTY OF LANDMARK SIGN GROUP, INC. NO REPRODUCTION OR DISTRIBUTION OF THIS DRAWING IS PERMITTED WITHOUT THE WRITTEN CONSENT OF LANDMARK SIGN GROUP, INC. AN AGREEMENT BY YOU TO USE AS WELL AS CHANGE WILL BE REQUIRED.