



# City of Chicago



O2013-4591

Office of the City Clerk

## Document Tracking Sheet

<b>Meeting Date:</b>	6/5/2013
<b>Sponsor(s):</b>	Burnett, Walter (27)
<b>Type:</b>	Ordinance
<b>Title:</b>	Grant(s) of privilege in public way for Parc Chestnut Condo Association- trash container
<b>Committee(s) Assignment:</b>	Committee on Transportation and Public Way

ORDINANCE  
PARC CHESTNUT CONDO ASSOCIATION  
Acct. No. 322674 - 1  
Permit No. 1106056

*Be It Ordained by the City Council of the City of Chicago:*

SECTION 1. Permission and authority are hereby given and granted to PARC CHESTNUT CONDO ASSOCIATION, upon the terms and subject to the conditions of this ordinance to maintain and use, as now constructed, one (1) Trash container(s) on the public right-of-way adjacent to its premises known as 849 N. Franklin St..

Said Trash container(s) at W. Chestnut Street measure(s):  
One (1) at one (1) foot in length, and three (3) feet in width for a total of three (3) square feet.

The location of said privilege shall be as shown on prints kept on file with the Department of Business Affairs and Consumer Protection and the Office of the City Clerk.

Said privilege shall be constructed in accordance with plans and specifications approved by the Department of Transportation (Division of Project Development).

This grant of privilege in the public way shall be subject to the provisions of Section 10-28-015 and all other required provisions of the Municipal Code of Chicago.

The grantee shall pay to the City of Chicago as compensation for the privilege #1106056 herein granted the sum of seventy-five (\$75.00) per annum in advance.

A 25% penalty will be added for payments received after due date.

The permit holder agrees to hold the City of Chicago harmless for any damage, relocation or replacement costs associated with damage, relocation or removal of private property caused by the City performing work in the public way.

Authority herein given and granted for a period of five (5) years from and after 03/12/2013.

Alderman

  
Walter Burnett Jr. 27th Ward

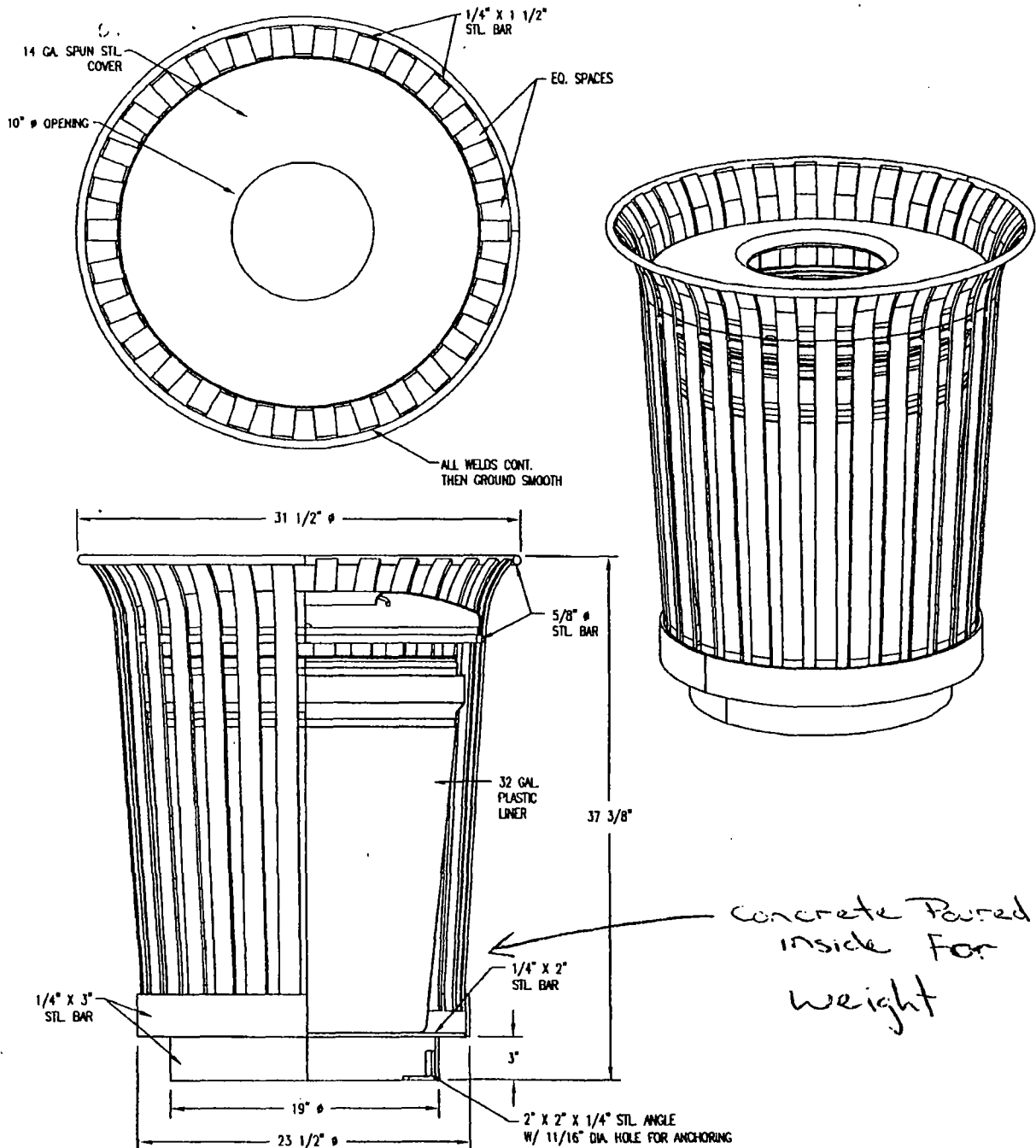

NOTES:

- 1.) ALL STL. MEMBERS COATED W/ ZINC RICH EPOXY THEN FINISHED W/ POLYESTER POWDER COATING.
- 2.) 1/2" X 3 3/4" EXPANSION ANCHOR BOLTS PROVIDED.
- 3.) ALL WELDS CONT. THEN GROUND SMOOTH.
- 4.) RECEPTACLE FULLY ASSEMBLED AT FACTORY.

 <b>DuMor, inc.</b> P.O. Box 142 Mifflintown, PA 17059-0142	SCALE :	NONE	TITLE :		RECEPTACLE
	DATE DRAWN :	12/12/96	REV.	DRAWING NUMBER	84-32-FTO
	DRAWN BY :	AH	F		
	DATE REV. :	12/27/06			
	REV. BY :	AWH			SHEET 1 OF 2



**06/05/2013**

**Alderman Walter Burnett Jr.**  
Ward # 27  
City of Chicago  
City Hall, Room 203  
121 North LaSalle Street  
Chicago, Illinois 60602

**Re: An ordinance to use and maintain a portion of the public right-of-way for one (1) trash container(s) for PARC CHESTNUT CONDO ASSOCIATION, adjacent to the premises known as 849 N. Franklin St..**

**Dear Alderman Walter Burnett Jr.:**

The applicant referenced above has requested the use of the public right-of-way for a **trash container(s)**. An ordinance has been prepared by the Department of Business Affairs and Consumer Protection – Business Assistance Center - Public Way Use Unit for presentation to the City Council. Because this request was made for properties located in your ward, as approved by you as per the attached, I respectfully request that you introduce the attached ordinance at the next City Council meeting.

If you have any questions regarding this ordinance, please contact Anthony Bertuca at (312) 744-5506.

**Department of Business Affairs and Consumer Protection**