



City of Chicago



O2017-354

Office of the City Clerk

Document Tracking Sheet

Meeting Date:	1/25/2017
Sponsor(s):	Thompson (11)
Type:	Ordinance
Title:	Grant(s) of privilege in public way for Express Grill, Inc.
Committee(s) Assignment:	Committee on Transportation and Public Way

ORDINANCE
EXPRESS GRILL INC
Acct. No. 295117 - 1
Permit No. 1125133

Be It Ordained by the City Council of the City of Chicago:

SECTION 1. Permission and authority are hereby given and granted to EXPRESS GRILL INC, upon the terms and subject to the conditions of this ordinance to maintain and use, as now constructed, one (1) Shelf(s) projecting over the public right-of-way adjacent to its premises known as 1260 S. Union Ave..

Said Shelf(s) at S. UNION AVENUE measure(s):

One (1) at twenty (20) feet in length, and one point three (1.3) foot in width for a total of twenty-six (26) square feet. Existing shelf is approximately three point five (3.5) feet above grade level.

The location of said privilege shall be as shown on prints kept on file with the Department of Business Affairs and Consumer Protection and the Office of the City Clerk.

Said privilege shall be constructed in accordance with plans and specifications approved by the Department of Transportation (Division of Project Development).

This grant of privilege in the public way shall be subject to the provisions of Section 10-28-015 and all other required provisions of the Municipal Code of Chicago.

The grantee shall pay to the City of Chicago as compensation for the privilege #1125133 herein granted the sum of four hundred (\$400.00) per annum in advance.

A 25% penalty will be added for payments received after due date.

The permit holder agrees to hold the City of Chicago harmless for any damage, relocation or replacement costs associated with damage, relocation or removal of private property caused by the City performing work in the public way.

Authority herein given and granted for a period of five (5) years from and after 11/15/2016.

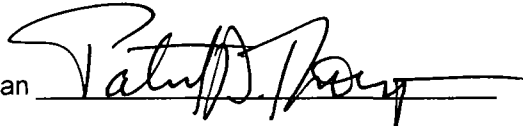
Alderman 
Patrick D. Thompson 11th Ward

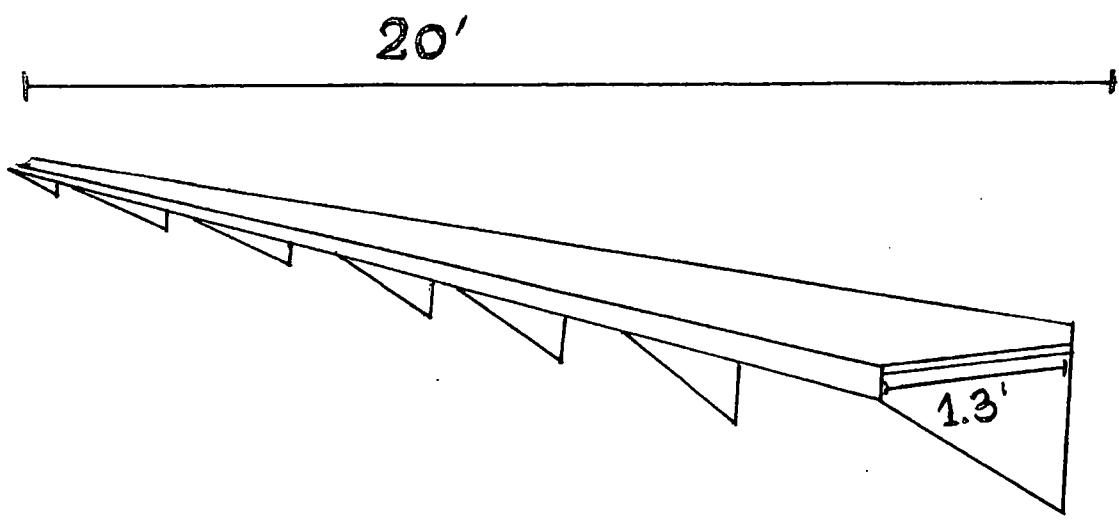

EXPRESS GRILL, INC.
1260 S UNION

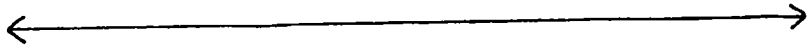



01/25/2017

Alderman Patrick D. Thompson
Ward # 11
City of Chicago
City Hall, Room 300
121 North LaSalle Street
Chicago, Illinois 60602

Re: An ordinance to use and maintain a portion of the public right-of-way for **one (1) shelf(s)** for **EXPRESS GRILL INC**, adjacent to the premises known as **1260 S. Union Ave.**.

Dear Alderman **Patrick D. Thompson**:

The applicant referenced above has requested the use of the public right-of-way for a **shelf(s)**. An ordinance has been prepared by the Department of Business Affairs and Consumer Protection – Small Business Center - Public Way Use Unit for presentation to the City Council. Because this request was made for properties located in your ward, as approved by you as per the attached, I respectfully request that you introduce the attached ordinance at the next City Council meeting.

If you have any questions regarding this ordinance, please contact Anthony Bertuca at (312) 744-5506.

Department of Business Affairs and Consumer Protection