



City of Chicago



O2016-6732

Office of the City Clerk

Document Tracking Sheet

Meeting Date:	9/14/2016
Sponsor(s):	Arena (45)
Type:	Ordinance
Title:	Awning(s) for CSD Six Corners LLC
Committee(s) Assignment:	Committee on Transportation and Public Way

ORDINANCE
CSD Six Corners LLC
Acct. No. 409478 - 1
Permit No. 1124424

Be It Ordained by the City Council of the City of Chicago:

SECTION 1. Permission and authority are hereby given and granted to CSD Six Corners LLC, upon the terms and subject to the conditions of this ordinance to construct, install, maintain and use seven (7) Awning(s) projecting over the public right-of-way adjacent to its premises known as 3967 N. Milwaukee Ave..

Said Awning(s) at N. Milwaukee measure(s):

One (1) at twenty (20) feet in length, and two point zero eight (2.08) feet in width for a total of forty-one point six (41.6) square feet.

One (1) at eighteen point three three (18.33) feet in length, and one point six seven (1.67) foot in width for a total of thirty point six one (30.61) square feet.

One (1) at ten (10) feet in length, and one point nine two (1.92) foot in width for a total of nineteen point two (19.2) square feet.

One (1) at twelve (12) feet in length, and two point zero eight (2.08) feet in width for a total of twenty-four point nine six (24.96) square feet.

Said Awning(s) at Kilpatrick measure(s):

One (1) at twelve (12) feet in length, and two point zero eight (2.08) feet in width for a total of twenty-four point nine six (24.96) square feet.

Said Awning(s) at Irving Park Road measure(s):

One (1) at fourteen (14) feet in length, and two point two five (2.25) feet in width for a total of thirty-one point five (31.5) square feet.

One (1) at twenty (20) feet in length, and one point six seven (1.67) foot in width for a total of thirty-three point four (33.4) square feet.

The location of said privilege shall be as shown on prints kept on file with the Department of Business Affairs and Consumer Protection and the Office of the City Clerk.

Said privilege shall be constructed in accordance with plans and specifications approved by the Zoning Department - Signs.

This grant of privilege in the public way shall be subject to the provisions of Section 10-28-015 and all other required provisions of the Municipal Code of Chicago.

The grantee shall pay to the City of Chicago as compensation for the privilege #1124424 herein granted the sum of one hundred seventy-five (\$175.00) per annum in advance.

A 25% penalty will be added for payments received after due date.

The permit holder agrees to hold the City of Chicago harmless for any damage, relocation or replacement costs associated with damage, relocation or removal of private property caused by the City performing work in the public way.

Authority herein given and granted for a period of five (5) years from and after Date of Passage.

Alderman _____

John Arena 45th Ward

Page 1

NOTE THIS ENCROACHMENT
CONDITION OCCURS AT 3
LOCATIONS

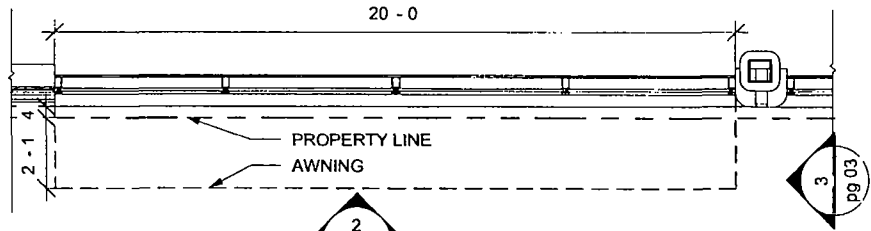

1 PLAN - AWNING 1
pg 03 SCALE 1/4" = 1'-0"

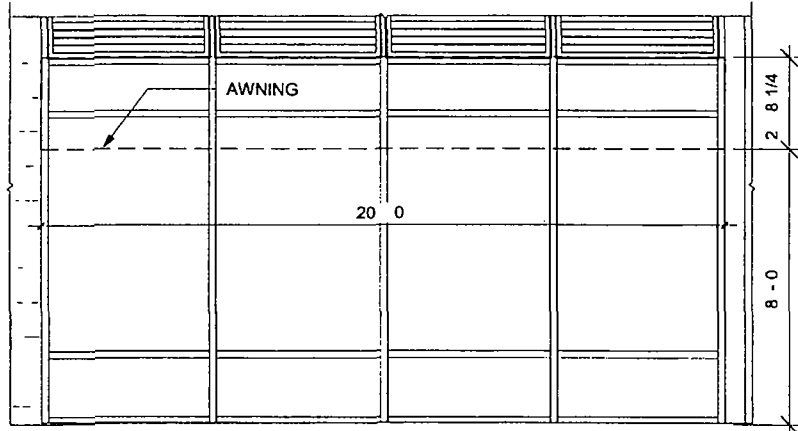
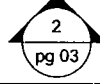

2 FRONT ELEVATION - AWNING 1
pg 03 SCALE 1/4" = 1'-0"

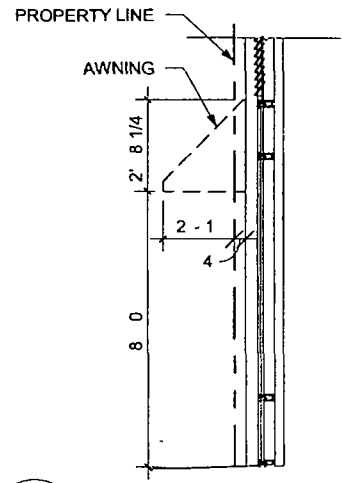

3 SIDE ELEVATION - AWNING 1
pg 03 SCALE 1/4" = 1'-0"



OKW Architects
600 West Jackson Blvd
Chicago IL 60661
T 312 798 7700
F 312 798 7777
www.okwarchitects.com

**SIX CORNERS
DEVELOPMENT**
3967 NORTH MILWAUKEE AVE CHICAGO IL
60641
DATE 07/11/16

SHEET NO
pg 03



09/14/2016

Alderman **John Arena**
Ward # **45**
City of Chicago
City Hall, Room **300**
121 North LaSalle Street
Chicago, Illinois 60602

Re: An ordinance to use and maintain a portion of the public right-of-way for **seven (7) awning(s)** for **CSD Six Corners LLC**, adjacent to the premises known as **3967 N. Milwaukee Ave.**.

Dear Alderman **John Arena**:

The applicant referenced above has requested the use of the public right-of-way for a **awning(s)**. An ordinance has been prepared by the Department of Business Affairs and Consumer Protection – Small Business Center - Public Way Use Unit for presentation to the City Council. Because this request was made for properties located in your ward, as approved by you as per the attached, I respectfully request that you introduce the attached ordinance at the next City Council meeting.

If you have any questions regarding this ordinance, please contact Anthony Bertuca at (312) 744-5506.

Department of Business Affairs and Consumer Protection