



City of Chicago



O2016-3256

Office of the City Clerk

Document Tracking Sheet

Meeting Date:	4/13/2016
Sponsor(s):	Reilly (42)
Type:	Ordinance
Title:	Grant(s) of privilege in public way for Zeller 401 Property LLC - siamese connection
Committee(s) Assignment:	Committee on Transportation and Public Way

ORDINANCE
ZELLER 401 PROPERTY, LLC.
Acct. No. 333725 - 1
Permit No. 1122689

Be It Ordained by the City Council of the City of Chicago:

SECTION 1. Permission and authority are hereby given and granted to ZELLER 401 PROPERTY, LLC., upon the terms and subject to the conditions of this ordinance to construct, install, maintain and use one (1) Siamese Connection(s) projecting over the public right-of-way adjacent to its premises known as 401 N. Michigan Ave..

Said Siamese Connection(s) at N. Michigan Avenue measure(s):

One (1) at point five eight (.58) feet in length, and point five eight (.58) feet in width for a total of point three four (.34) square feet.

The location of said privilege shall be as shown on prints kept on file with the Department of Business Affairs and Consumer Protection and the Office of the City Clerk.

Said privilege shall be constructed in accordance with plans and specifications approved by the Department of Transportation (Division of Project Development).

This grant of privilege in the public way shall be subject to the provisions of Section 10-28-015 and all other required provisions of the Municipal Code of Chicago.

The grantee shall pay to the City of Chicago as compensation for the privilege #1122689 herein granted the sum of four hundred (\$400.00) per annum in advance.

A 25% penalty will be added for payments received after due date.

The permit holder agrees to hold the City of Chicago harmless for any damage, relocation or replacement costs associated with damage, relocation or removal of private property caused by the City performing work in the public way.

Authority herein given and granted for a period of five (5) years from and after Date of Passage.

Alderman _____

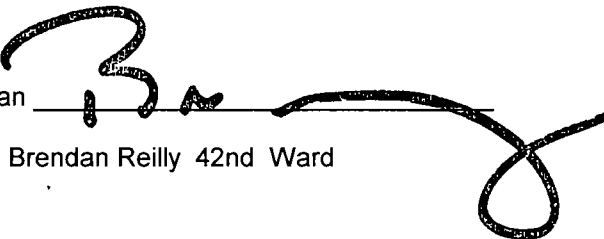
A handwritten signature in black ink, appearing to read 'B. Reilly', written over a horizontal line. The signature is stylized and extends to the right of the line.

Brendan Reilly 42nd Ward

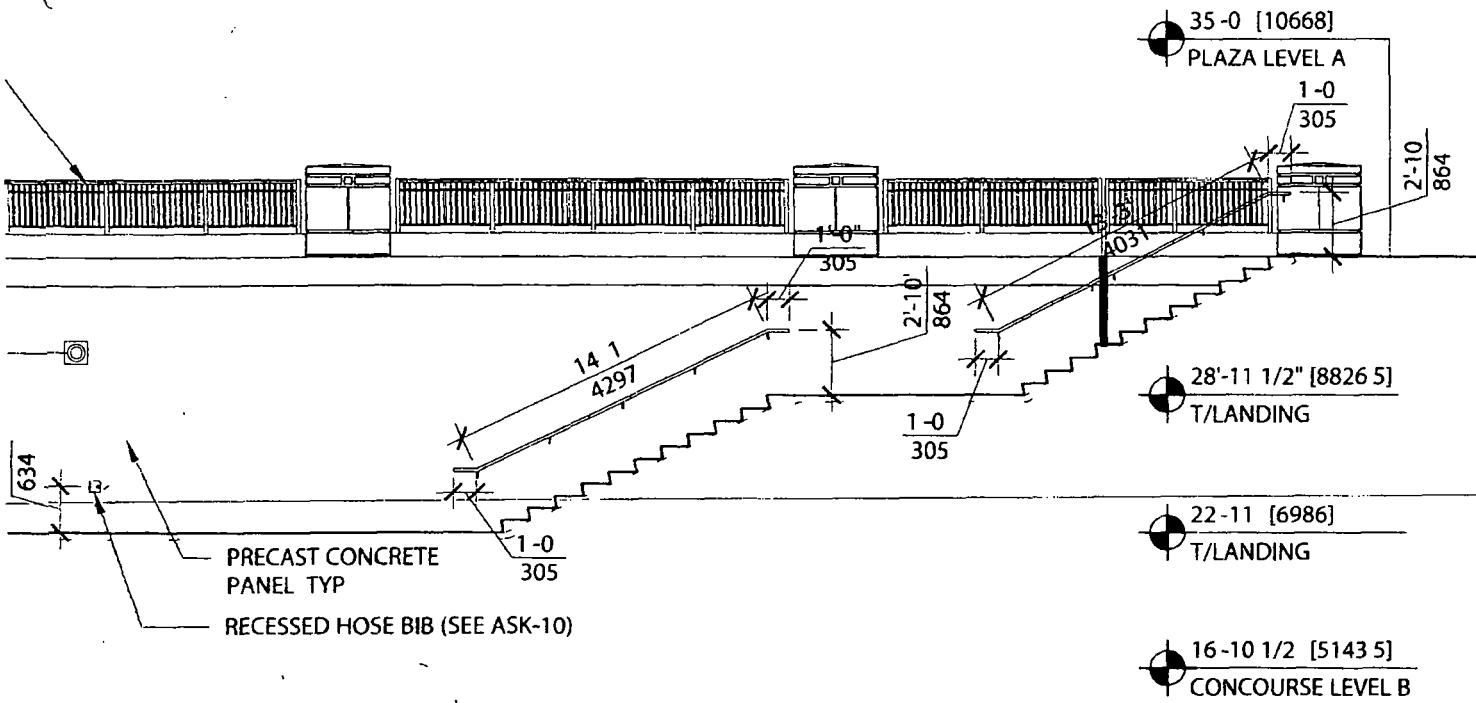

SCHEDULES

WIFI ENCLOSURE		
QTY	DIMENSION (WxHxD)	AREA
1	12 in x 12 in x 7 in	1 SF

RECESSED HOSE BIB		
QTY	DIMENSION (WxH)	AREA
1	7 in x 7 in BOX	0.35 SF

HANDRAILS	
QTY	LENGTH
1	15.25 LF
1	16.08 LF
1	20.0 LF

CAMERAS		
QTY	DIMENSION (WxH)	AREA
2	11.5 in x 11.5 in	2 SF

OPENINGS PRECAST MAINTENANCE DOOR		
QTY	DIMENSION (WxH)	AREA
1	7'-10 1/2" x 8'-5"	66 SF



401 NMA Riverfront Retail
 401 North Michigan Avenue
 Chicago-IL 60611

1554 00 GOP SUPPLEMENTAL - ELEVATION
 02/22/16 SEE DRAWINGS ASK-08