



City of Chicago



O2019-8915

Office of the City Clerk Document Tracking Sheet

Meeting Date:	11/13/2019
Sponsor(s):	Osterman (48)
Type:	Ordinance
Title:	Grant(s) of privilege in public way for Lau Medical
Committee(s) Assignment:	Committee on Transportation and Public Way

ORDINANCE
Lau Medical
Acct. No. 463247 - 1
Permit No. 1142500

Be It Ordained by the City Council of the City of Chicago:

SECTION 1. Permission and authority are hereby given and granted to Lau Medical, upon the terms and subject to the conditions of this ordinance to maintain and use one (1) sign(s) projecting over the public right-of-way attached to its premises known as 1102 W. Argyle St..

Said sign structure(s) measures as follows; along W. Argyle:
One (1) at eighteen point five (18.5) feet in length, three point two five (3.25) feet in height and nine (9) feet above grade level.

The location of said privilege shall be as shown on prints kept on file with the Department of Business Affairs and Consumer Protection and the Office of the City Clerk.

Said privilege shall be constructed in accordance with plans and specifications approved by the Department of Transportation (Division of Project Development) and Zoning Department - Signs.

This grant of privilege in the public way shall be subject to the provisions of Section 10-28-015 and all other required provisions of the Municipal Code of Chicago.

The grantee shall pay to the City of Chicago as compensation for the privilege #1142500 herein granted the sum of three hundred (\$300.00) per annum in advance.

A 25% penalty will be added for payments received after due date.

The permit holder agrees to hold the City of Chicago harmless for any damage, relocation or replacement costs associated with damage, relocation or removal of private property caused by the City performing work in the public way.

Authority herein given and granted for a period of five (5) years from and after Date of Passage.

Alderman  _____

Harry Osterman 48th Ward

SIGN 1: INTERNALLY ILLUMINATED CHANNEL LETTER

Front-Lit, Channel Letters w/ LED, Wireway Mounted



SPECIFICATIONS	
Area	40"H x 224"W
Total Sq Ft	62 22 ft ²
Returns	Black
Trimcap	Black
Illumination	White LED
Face	White, Blue
Wireway	Brown Wood Pattern

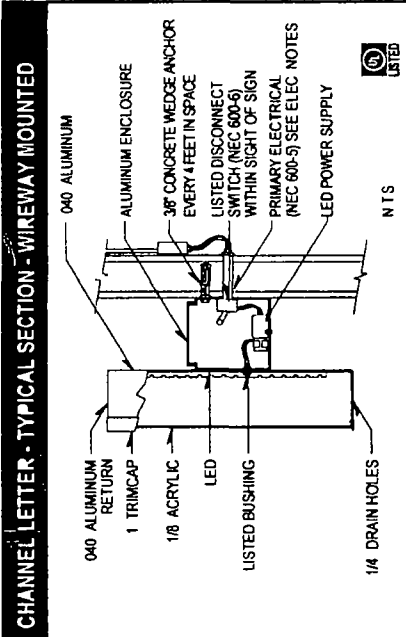

Note
 This sign is intended to be installed in accordance with the requirements of Article 600 of the National Electrical Code (NEC) and other applicable local codes. This includes proper grounding and bonding of the sign.

L37 Grounding and Bonding Statement
 This sign is intended to be installed in accordance with the requirements of Article 600 of the National Electrical Code (NEC) and other applicable local codes. This includes proper grounding and bonding of the sign.

ELECTRICAL NOTES

1. A minimum of one electrical 120V 20A circuit.
2. Junctions shall be made within 12 feet of sign.
3. Three wires plus ground required.

Ground sign must have:
 1. A minimum of one electrical 120V 20A circuit.
 2. Junctions shall be made within 12 feet of sign.
 3. Three wires plus ground required.

NOTE Elevation drawings are for customer approval only, drawings are not to be used as any installation guide, all dimensions must be verified before installation

	Client Name Lau Medical Location 1102 W Argyle St Chicago IL 60640	Start Date 09/20/19 Last Revision Job# Drawing# Page 3/3	• Client Approval • Landlord Approval	Sales Rep kw Designer Simon L	
	© COPYRIGHT 2019 BY MONSIBICI INC. ALL DESIGNS PRESENTED ARE THE SOLE PROPERTY OF MONSIBICI INC. AND MAY NOT BE REPRODUCED IN PART OR WHOLE WITHOUT WRITTEN PERMISSION FROM MONSIBICI INC.				



Department of Business Affairs and Consumer Protection
Small Business Center - Public Way Use Unit
City Hall - 121 N LaSalle Street, Room 800 • Chicago, IL 60602
312-74-GOBIZ / 312-744-6249 • (312) 744-1944 (TTY)
<http://www.cityofchicago.org/bacp>

11/13/2019

Alderman **Harry Osterman**
Ward # **48**
City of Chicago
City Hall, Room **300**
121 North LaSalle Street
Chicago, Illinois 60602

Re: An ordinance to use and maintain a portion of the public right-of-way for **one (1) sign(s)** for **Lau Medical**, adjacent to the premises known as **1102 W. Argyle St.**

Dear Alderman **Harry Osterman**:

The applicant referenced above has requested the use of the public right-of-way for a **sign(s)**. An ordinance has been prepared by the Department of Business Affairs and Consumer Protection – Small Business Center - Public Way Use Unit for presentation to the City Council. Because this request was made for properties located in your ward, as approved by you as per the attached, I respectfully request that you introduce the attached ordinance at the next City Council meeting.

If you have any questions regarding this ordinance, please contact Anthony Bertuca at (312) 744-5506.

Department of Business Affairs and Consumer Protection