



Office of the Chicago City
Clerk



O2012-4561

Office of the City Clerk

City Council Document Tracking Sheet

Meeting Date:	6/27/2012
Sponsor(s):	Burns, William D. (4)
Type:	Ordinance
Title:	Grant(s) of privilege in public way for Lake Park Associates Inc.
Committee(s) Assignment:	Committee on Transportation and Public Way

ORDINANCE
LAKE PARK ASSOCIATES, INC.
Acct. No. 43697 - 108
Permit No. 1101896

Be It Ordained by the City Council of the City of Chicago:

SECTION 1. Permission and authority are hereby given and granted to LAKE PARK ASSOCIATES, INC., upon the terms and subject to the conditions of this ordinance to construct, install, maintain and use two (2) Light Fixture(s) projecting over the public right-of-way adjacent to its premises known as 5226 S. Harper Ave..

Said Light Fixture(s) at S HARPER AVE measure(s):

Two (2) at two point seven five (2.75) feet in length, one point five eight (1.58) foot in width and sixteen point five (16.5) feet above grade level.

The location of said privilege shall be as shown on prints kept on file with the Department of Business Affairs and Consumer Protection and the Office of the City Clerk.

Said privilege shall be constructed in accordance with plans and specifications approved by the Department of Transportation (Division of Project Development).

This grant of privilege in the public way shall be subject to the provisions of Section 10-28-015 and all other required provisions of the Municipal Code of Chicago.

The grantee shall pay to the City of Chicago as compensation for the privilege #1101896 herein granted the sum of twenty-five (\$25.00) per annum in advance.

A 25% penalty will be added for payments received after due date.

The permit holder agrees to hold the City of Chicago harmless for any damage, relocation or replacement costs associated with damage, relocation or removal of private property caused by the City performing work in the public way.

Authority herein given and granted for a period of five (5) years from and after Date of Passage.

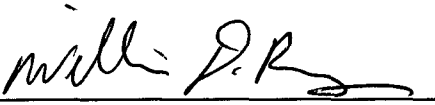
Alderman 

William D. Burns 4th Ward

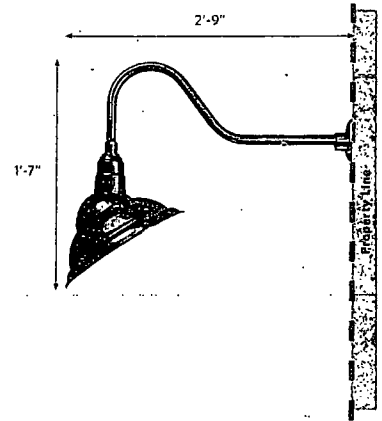

Gooseneck Lamp Side View

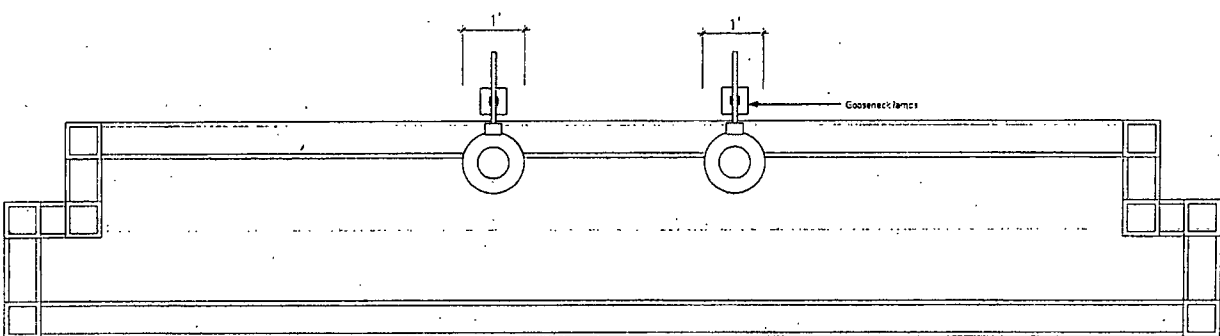

Primary Sign Front Elevation
1" = 1'-0"



Primary Sign Side View
1" = 1'-0"

KILWINS PRIMARY SIGN & LIGHTING



Department of Business Affairs and Consumer Protection
Business Assistance Center - Public Way Use Unit
City Hall - 121 N. LaSalle Street, Room 800 • Chicago, IL 60602
(312)-74-GOBIZ (312-744-6249) • (312) 744-1944 (TTY)
<http://www.cityofchicago.org/bacp>

06/27/2012

Alderman **William D. Burns**
Ward # **04**
City of Chicago
City Hall, Room **300**
121 North LaSalle Street
Chicago, Illinois 60602

Re: An ordinance to use and maintain a portion of the public right-of-way for **two (2) light fixture(s)** for **LAKE PARK ASSOCIATES, INC.**, adjacent to the premises known as **5226 S. Harper Ave.**.

Dear Alderman **William D. Burns**:

The applicant referenced above has requested the use of the public right-of-way for a **light fixture(s)**. An ordinance has been prepared by the Department of Business Affairs and Consumer Protection – Business Assistance Center - Public Way Use Unit for presentation to the City Council. Because this request was made for properties located in your ward, as approved by you as per the attached, I respectfully request that you introduce the attached ordinance at the next City Council meeting.

If you have any questions regarding this ordinance, please contact Anthony Bertuca at (312) 744-5506.

Department of Business Affairs and Consumer Protection