



City of Chicago



O2017-5529

Office of the City Clerk

Document Tracking Sheet

Meeting Date: 7/26/2017

Sponsor(s): Emanuel (Mayor)

Type: Ordinance

Title: Amendment of Municipal Code by adding new Title 14E and modifying Titles 1, 2, 4, 10, 13, 15 and 18 regarding electrical code

Committee(s) Assignment: Committee on Zoning, Landmarks and Building Standards



OFFICE OF THE MAYOR
CITY OF CHICAGO

RAHM EMANUEL
MAYOR

July 26, 2017

TO THE HONORABLE, THE CITY COUNCIL
OF THE CITY OF CHICAGO

Ladies and Gentlemen:

At the request of the Building Commissioner, I transmit herewith an ordinance amending Chapter 18-27 of the Municipal Code.

Your favorable consideration of this ordinance will be appreciated.

Very truly yours,

Mayor

ORDINANCE

BE IT ORDAINED BY THE CITY COUNCIL OF THE CITY OF CHICAGO:

This ordinance is organized into six Articles, as follows:

Article I.	2017 Electrical Code
Article II.	Other Applicable Code Amendments
Article III.	Repealer of Existing Electrical Code
Article IV.	Administration
Article V.	Smoke and Carbon Monoxide Detection
Article VI.	Effective Date

ARTICLE I. 2017 ELECTRICAL CODE

SECTION 1. The Municipal Code of Chicago is hereby amended by inserting a new Title 14E, as follows:

TITLE 14E: ELECTRICAL CODE CHAPTER 14E-1 GENERAL

14E-1-010 Adoption of the National Electrical Code by reference

NFPA 70, National Electrical Code, 2017 edition (hereinafter known as NFPA 70), is adopted by reference and shall be considered part of the requirements of this title except as modified by the specific provisions of this title.

If differences occur between a provision modified by this title and a provision adopted without modification, the modified provision shall control.

14E-1-020 Citations

Provisions of NFPA 70 which are incorporated into this title by reference may be cited as follows:

14E-[NFPA 70 chapter number]-[NFPA 70 section number].

Citations within this title and within the provisions of NFPA 70 which are incorporated into this title by reference shall be read to incorporate "14E-[chapter number]-" as a prefatory part of the citation.

14E-1-090 Introduction

The provisions of Article 90 of NFPA 70 are adopted by reference with the following modifications:

Delete subsection 90.1(C) and the subsequent informational note.

Revise subsection 90.2(B)(4) to read:

"Installations of communications equipment under the exclusive control of communications utilities located outdoors or in building spaces used exclusively for such installations, where such installations are under the jurisdiction of the Illinois Commerce Commission or other State or Federal regulatory body"

Revise subsection 90.2(B)(5) to read:

"Installations under the exclusive control of an electric utility where such installations

- a. Consist of service drops or service laterals, and associated metering, or
- b. Are located in legally established easements or rights-of-way designated by or recognized by public service commissions, utility commissions, or other regulatory agencies having jurisdiction for such installations, or
- c. Are on property owned or leased by the electric utility for the purpose of communications, metering, generation, control, transformation, transmission, energy storage or distribution of electric energy."

Revise subsection 90.2(C) to read:

"Special Permission. The authority having jurisdiction for enforcing this *Code* may grant exception for the installation of conductors and equipment that are not under the exclusive control of the electric utilities and are used to connect the electric utility supply system to the service conductors of the premises served, provided such installations are outside a building or structure, or terminate immediately inside a building wall. Such special permission shall in all cases be obtained from the authority having jurisdiction in writing prior to the commencement of the installation."

Revise section 90.4 to read:

"Enforcement. The authority having jurisdiction for enforcement of the *Code* has the responsibility for making interpretations of the rules, for deciding on the approval of equipment and materials, and for granting the special permission contemplated in a number of the rules.

By special permission, the authority having jurisdiction may waive specific requirements in this *Code* or permit alternative methods where it is assured that equivalent objectives can be achieved by establishing and maintaining effective safety. The authority having jurisdiction may not waive or alter the requirements of 300.22(C)."

Revise section 90.6 to read:

“Formal Interpretations. To promote uniformity of interpretation and application of the provisions of this *Code*, the authority having jurisdiction may issue formal interpretations.”

14E-1-100 Definitions

The provisions of Article 100 of NFPA 70 are adopted by reference with the following modifications:

Revise the definition of “Approved” to read:

“Acceptable to the authority having jurisdiction. No equipment, device or appliance covered by the provisions of this title shall be approved unless it has been tested by and bears the label of an approved testing laboratory. Any testing laboratory currently recognized as a Nationally Recognized Testing Laboratory (NRTL) by the United States Occupational Health and Safety Administration (OSHA) is approved. Self-certification of equipment or installations shall not be acceptable.”

Revise the definition of “Authority Having Jurisdiction (AHJ)” to read:

“The commissioner of buildings.”

Insert the following language after the definition of “Building”:

“Building, High Rise. A building more than 24.4 m (80 ft) in height.”

Insert the following language after the definition of “Electrical Circuit Protective System”:

“Electrical Contractor. A person who is registered pursuant to Chapter 4-290.”

Insert the following language after the definition of “Handhole Enclosure”:

“Hard Surface Ceiling. A ceiling with a finished surface of plaster, drywall, or similar material, specifically excluding acoustical tile or similar types of ceilings.

Revise the definition of “In Sight From (Within Sight From, Within Sight)” to read:

“Where this *Code* specifies that one equipment shall be “in sight from,” “within sight from,” or “within sight of,” and so forth, another equipment, the specified equipment is to be visible and not more than 15 m (50 ft) distant from the other and as close as practicable to the other.”

Revise the definition of “Qualified Person” to read:

“One who is or is under the direct supervision of a supervising electrician, has skills and knowledge related to the construction and operation of the electrical equipment and installations and has received safety training to recognize and avoid the hazards involved.”

Insert the following language after the definition of “Show Window”:

“Sign. A name, identification, description, display, illustration or character which is affixed to or represented directly or indirectly upon a building, structure, or piece of land and which directs attention to an object, product, place, activity, person, institution, organization or business. Furthermore for purposes of Title 14E, signs shall also include anything meeting the definition of “sign” in Section 17-17-02159.”

Insert the following language after the definition of “Structure”:

“Supervising Electrician. A person who is registered pursuant to Chapter 4-292.”

14E-1-110 Requirements for Electrical Installations

The provisions of Article 110 of NFPA 70 are adopted by reference with the following modifications:

Insert new subsection 110.12(C) to read:

“Abandoned Electrical Equipment. All accessible (as applied to wiring methods) abandoned raceways, cables, conductors, boxes, and electrical equipment shall be removed.”

Insert new subsection 110.26(G) to read:

“Dedicated Electrical Closets. In high rise buildings, where vaults, transformers and/or distribution points are established throughout the various floors or areas of the building, all such electrical equipment shall be grouped and installed in an approved electrical closet.

Such electrical closet(s) shall be for the exclusive use of the electrical system and shall be constructed as to provide the required working space around all of the electrical equipment installed therein. Such electrical closet(s) shall have an adequate fire rating and be protected in an approved manner and shall comply with 230.70.

Where busways serve such electrical closets, the busway shall only pass through areas meeting the fire rating, exclusive use, and fire protection requirements as the electrical closet. Busways located in areas with sprinkler protection shall be of the weatherproof or raintight type.”

CHAPTER 14E-2 WIRING AND PROTECTION

14E-2-200 Use and Identification of Grounded Conductors

The provisions of Article 200 of NFPA 70 are adopted by reference with the following modifications:

Insert new subsection 200.5 to read:

“Color Code of Grounded Branch Circuit and Grounded Feeder Circuit Conductors.

Grounded branch circuit and grounded feeder circuit conductors shall be identified in accordance with either 200.5 (A) or (B), as applicable.

(A) 150 Volts to Ground or Less. The grounded conductor of branch circuit and feeder conductors rated 150 volts to ground or less shall be identified by a continuous white outer finish.

(B) Over 150 Volts to Ground. The grounded conductor of branch circuit and feeder conductors rated over 150 volts to ground shall be identified by a continuous gray outer finish.”

14E-2-210 Branch Circuits

The provisions of Article 210 of NFPA 70 are adopted by reference with the following modifications:

Revise subsection 210.4(C)(1) to read:

“Branch Circuit Ungrounded Conductors. Branch circuit ungrounded conductors:

(a) Rated 150 volts to ground or less shall use the following color code: black, red, and blue.

(b) Rated over 150 volts to ground shall use the following color code: brown, orange, and yellow

(c) On a 4-wire, delta-connected system where the midpoint of one phase winding is grounded, the high phase branch circuit conductor shall be durably and permanently marked by an outer finish that is orange in color.”

Revise the first clause of subsection 210.6(C) to read:

“277 Volts to Ground. Provided the premises is under the supervision of a supervising electrician, circuits exceeding 120 volts, nominal, between conductors and not exceeding 277 volts, nominal, to ground shall be permitted to supply the following:

(1) Listed electric-discharge or listed light-emitting diode- type luminaires:

(2) The luminaires are installed at least 2.44 m (8 ft) above the floor, luminaires are permanently installed, switching is controlled by low voltage control relays or by listed circuit breakers used as switches and marked SWD or HID

(3) Luminaires equipped with mogul-base screw shell lampholders and complies with 210.6(C)(1) requirements.

(4) Cord-and-plug-connected or permanently connected utilization equipment and complies with 210.6(C) (1) requirements:

Revise the first clause of subsection 210.6(D) to read:

“600 Volts Between Conductors. Provided the premises is under the supervision of a supervising electrician, circuits exceeding 277 volts, nominal, to ground and not exceeding 600 volts, nominal, between conductors shall be permitted to supply the following:”

Revise subsection 210.12 to read:

“Arc-Fault Circuit-Interrupter Protection. Arc-fault circuit-interrupter protection shall be provided as required in 210.12(A), (B), and (C). The arc-fault circuit interrupter shall be installed in a readily accessible location.

(A) Dwelling Units. All 120-volt, single phase, 15- and 20-ampere branch circuits supplying outlets and devices installed in dwelling units shall be protected by a listed arc-fault circuit interrupter, combination-type, installed to provide protection of the branch circuit.

(B) Dormitory Units. All 120-volt, single phase, 15- and 20-ampere branch circuits supplying outlets and devices installed in dormitory units shall be protected as described in 210.12(A).

(C) Guest Rooms and Guest Suites. All 120-volt, single-phase, 15- and 20- ampere branch circuits supplying outlets and devices installed in guest suites and guest rooms of hotels and motels shall be protected as described in 210.12(A).

(D) Branch Circuit Extensions or Modifications -- Dwelling Units and Dormitory Units. In any of the areas specified in 210.12(A) or (B), where branch-circuit wiring is modified, replaced or extended, the branch-circuit shall be protected by one of the following:

(1) A listed combination-type AFCI located at the origin or the branch circuit.

(2) A listed outlet branch-circuit type AFCI located at the first outlet of the existing branch circuit.

Exception No. 1 to 210.12(A), (B), (C) and (D): It shall be permitted to omit arc-fault protection for that portion of the branch circuit enclosed in rigid metal conduit (RMC), intermediate metal conduit (IMC), electrical metal tubing (EMT), or Type MI Cable sheath meeting the requirements of 250.118 along with metal outlet and junction boxes.

Exception No. 2 to 210.12(A), (B), (C) and (D): Where an individual branch circuit to a fire alarm system is installed in accordance with 760.41(B) or 760.121(B) is installed in rigid metal conduit (RMC), intermediate metal conduit (IMC), electrical metal tubing (EMT), or Type MI Cable sheath meeting the requirements of 250.118, with metal outlet and junction boxes, AFCI protection shall be permitted to be omitted.

Informational Note No. 1: For information on types of arc-fault circuit interrupters, see UL 1699-latest edition, Standard for Arc-Fault Circuit Interrupters.

Informational Note No. 2: See 11.6.3(5) of NFPA 72, National Fire Alarm and Signaling Code, for information related to secondary power supply requirements for smoke alarms installed in dwelling units.

Informational Note No. 3: See 760.41(B) and 760.121(B) for power-supply requirements for fire alarm systems.

Insert new subsections 210.70(A)(2)(5) and (A)(2)(6) to read:

“(5) At least one wall switch-controlled lighting outlet shall be installed in clothes closets and other closets over 2.3m² (25 ft²). Closet luminaires shall be permanently installed lighting outlets.

(6) At least one wall switch-controlled lighting outlet shall be installed over each sink or basin located in a room or area that is greater than 5.95 m² (64 ft²). Such lighting outlets shall be in addition to the general lighting outlets installed in the room or area.”

14E-2-215 Feeders

The provisions of Article 215 of NFPA 70 are adopted by reference with the following modifications:

Revise subsection 215.5 to read:

“**Diagrams of Feeders.** A diagram showing feeder details shall be provided to the authority having jurisdiction prior to the installation of the feeders in accordance with 215.5(A) and (B).

(A) Plans Required. In new or remodeled buildings, complete and detailed electrical plans are required prior to the start of work on the following installations:

- (1) Dwelling occupancies in buildings greater than two stories in height
- (2) Non-dwelling occupancies in buildings greater than one story in height or greater than 929 m² (10,000 ft²) in area
- (3) New or replacement services or feeders rated 400 amperes or greater
- (4) Service switchboards and motor control centers rated in excess of 1200 amperes or 600 volts

(B) Plan Content. The plans shall include where applicable, the following:

- (1) A single-line drawing of the service and distribution
- (2) Schedule of conduits, wire, switches, circuit breakers, overcurrent devices, transformers, motors and luminaires
- (3) Load calculations to verify sizes of services, feeders, and panelboards indicating available fault-current and withstand ratings
- (4) Grounding electrode conductor or common grounding electrode conductor system
- (5) Equipment layout in switchboard rooms and electrical closets indicating the working space required by 110.26”

Revise subsection 215.12(C)(1) to read:

“**(1) Feeder Ungrounded Conductors.** Feeder ungrounded conductors:

- (a) Rated 150 volts to ground or less shall use the following color code: black, red, and

blue.

(b) Rated over 150 volts to ground shall use the following color code: brown, orange, and yellow.

(c) On a 4-wire, delta-connected system where the midpoint of one phase winding is grounded, the high phase feeder conductor shall be durably and permanently marked by an outer finish that is orange in color.”

14E-2-220 Branch Circuits, Feeders, and Service Calculations

The provisions of Article 220 of NFPA 70 are adopted by reference without modification.

14E-2-225 Outside Branch Circuits and Feeders

The provisions of Article 225 of NFPA 70 are adopted by reference with the following modifications:

Revise section 225.10 to read:

“Wiring on Buildings (or Other Structures). The installation of outside wiring on surfaces of buildings (or other structures) shall be permitted for circuits of not over 1000 volts, nominal, as the following:

- (1) Type MI cable
- (2) Rigid metal conduit
- (3) Intermediate metal conduit
- (4) Electrical metallic tubing.”

Insert new Part IV to read:

“Part IV. Outside Lighting

225.70. General. Part IV lists the requirements for outside lighting on public and private property that are in addition to the requirements of 225.7.

225.71. Commercial Lighting on Public Property.

(A) Supports. Commercial lighting on public property shall be supported on a post erected to support the post under the worst expected conditions.

Informational Note: For expected conditions in this area, see ANSI C2-2012, National Electrical Safety Code.

(B) Location. Each post shall be installed so that the lower edge of the post shall be on a line with the upper edge of the street curb and the center of the post shall be not less than 557 mm (22 in.) from the outer edge of the curb. Where a number of posts are erected or where posts are erected in addition to existing posts, they shall be located so that the globes shall be in a line with each other.

Exception: In the case of exceptionally narrow sidewalks or where large diameter pole bases are used, the 557 mm (22 in.) dimension may be reduced by the Department of Transportation.

(C) Separation from Fire Hydrants. No post shall be erected closer than 1.5 m (5 ft) to a fire hydrant.

(D) Street Corners. Posts erected at street corners shall not be located in the area defined by extending the building lines or right-of-way lines, if no building is present, to the curb.

(E) Spacing. Where more than one post is installed or where posts are installed in the immediate vicinity of other posts, spacing in any block shall be uniform and not less than 12.2 m (40 ft) nor more than 15.2 m (50 ft)

Exception: Where photometrics are acceptable to the Department of Transportation, a spacing greater than 15.2 m (50 ft) shall be permitted.

225.72. Commercial Lighting Foundations. All commercial lighting posts require concrete foundations. Concrete foundations shall be not less than 610 mm (24 in.) by 610 mm (24 in.) or 676 mm (27 in.) in diameter and shall extend below the frost line but not less than 914 mm (36 in.) below grade. Actual foundation dimensions shall be approved by the Department of Transportation.

Exception: Where commercial lighting is installed on vaulted walks or areas, a foundation shall not be required. All such supports and designs shall be first approved by the Department of Transportation.

225.74. Attachment to Concrete Foundation. Posts attached to concrete foundations shall be attached by a method which will permit the removal of the post from its foundation without damage to the post or foundation. Where the method of fastening is by means of a spider extending outward from the post base, the top of the foundation before the post is installed shall be left 76 mm (3 in.) below the top surface of the walk.

After the post has been aligned and fastened, the foundation shall be made flush with the top surface of the walk and no part of the spider or bolts shall project above the surface of the walk. In cases where posts are to be installed on unexcavated walk, the surface of the walk shall be recessed.

(A) Posts Set on Concrete Foundations. Where posts are set on concrete foundations, they shall be attached by bolts extending into and firmly held by the concrete foundation for a distance of not less than 762 mm (30 in.) For concrete posts, there shall be a minimum of three bolts not less than 16 mm (5/8 in.) diameter. The bolts shall be set such that they shall not pull out of the concrete nor turn due to the screwing on of a nut.

(B) Bolts. All bolts for attaching of posts shall be hot galvanized.

225.75. Concrete for Foundations. Concrete for foundations shall be made of at least 3000 psi concrete mix with a minimum cement content of 470 lb/yd³ of concrete or shall be standard class SI concrete (IDOT Section 1020). Proper admixtures, such as air-

entraining admixture (for concrete exposed to freezing and thawing) and water-reducing admixture (for placement and workability) shall be added to the concrete.

Informational Note: The use of Ready-Mix Concrete per ASTM C94 is recommended.

225.76. Conductors and Wiring for Commercial Lighting on Public Property.

Conductors outside of buildings for post lighting circuits shall be installed in rigid metal conduit, intermediate metal conduit or Schedule 80 nonmetallic rigid conduit a minimum of 610 mm (24 in.) beneath the surface of the ground, sidewalks, streets, alleys or parkways, or be enclosed by the post. Conductors within buildings shall be run in suitable conduits.

(A) Conductors. Conductors shall consist of a two or three wire cable not smaller than 12 AWG and have an approved insulation. Conductors smaller than 8 AWG shall be supported by a messenger.

(B) Protection Against Physical Damage. Conductors shall be protected from physical damage in accordance with 300.5.

(C) Metallic Sheath. The metallic sheath of cables shall be grounded.

(D) Disconnects. Branch circuits supplying street posts shall be protected by fuses rated not more than 20 amperes.

(E) Splices. Splices shall be made within approved junction boxes inside of buildings and in post heads outside of buildings.

225.81. Supports. Commercial lighting on private property shall be supported on a post erected to support the post under the worst expected conditions.

Informational Note No. 1: For expected conditions in this area, see ANSI C2-2012, National Electrical Safety Code

Informational Note No. 2: Planking the pole, "raking" the pole during installation, and similar methods of support should be considered during design.

(A) Materials. Supports may be standard wood poles, metal poles if suitably protected against corrosion, or clear timber. Except in hazardous locations, metal poles shall be provided with a hand hole through which the connections to the branch circuits shall be permitted to be made.

(B) Size and Strength. Minimum strength shall be equivalent to a Class 5 wood pole and in no case less than that required by 225.81.

225.82. Conductors and Wiring for Commercial Lighting on Public Property.

Conductors shall consist of a two or three wire cable not smaller than 12 AWG and have an approved insulation.

(A) Conductors Smaller than 8 AWG. Conductors smaller than 8 AWG shall be permitted to be a twisted pair or run parallel and taped. They shall be attached to and supported by a messenger at intervals not exceeding 1.52 m (5 ft).

(B) Conductors 8 AWG or Larger. Conductors No. 8 or larger shall use standard strain insulators at supports.

(C) Conductor Spans. Spans attached to buildings shall not exceed 30.5 m (100 ft) in length. Spans supported by clear timbers shall not exceed 18.2 m (60 ft) in length.

(D) Messenger Wires. Messenger wires shall be galvanized and not smaller than 10 AWG.

225.83. Clearances for Commercial Lighting on Public Property.

(A) From Ground or Grade. Conductors shall be installed in accordance with the clearance requirements of 225.18.

(B) Feeder Wires. Feeder wires shall be separated by at least 305 mm (12 in.) and supported on approved insulators of glass or porcelain when not in conduit.

225.84. Disconnects for Commercial Lighting on Public Property. Cutouts and switches installed outdoors shall be in standard weatherproof cabinets. Cabinets installed with the bottom less than 2.44 m (8 ft) above grade shall be locked.

225.85. Connections. Connections in sockets or receptacles shall be of the standard molded "pigtail" weatherproof type. Connections of socket wires shall be staggered.

225.90. Underground Branch Circuits. Where branch circuit conductors are from an underground feed, the requirements of (A) and (B) of this section shall apply.

(A) Underground Branch Circuits Attached to Wood Poles. Where rigid metal conduit or flexible metal conduit, where approved, is used it shall be installed a minimum of 2.44 m (8 ft) up the pole and to within 457 mm (18 in.) of the lighting fixture and made electrically continuous and grounded. Where cord is used it shall contain a separate grounding conductor which shall be continuous back to the distribution cabinet.

(B) Underground Branch Circuits Attached to Metal Poles. Rigid metal conduit shall be stubbed through the below grade and fitted with a grounding type bushing. The pole shall be bonded to the conduit with a minimum 8 AWG wire. Where direct buried conductors or cable or non-metallic raceway is used, a separate grounding conductor shall be provided back to the distribution cabinet. Where rigid metal conduit is used, all segments of the raceway system shall be bonded together and shall be permitted to be used as the ground.

225.91. Disconnects for Metal Poles. Approved fuseholders shall be permitted to be installed in metal poles provided that they are accessible to qualified personnel only and there are no live parts exposed.

225.92. Voltages Permitted. Voltages permitted shall be as indicated in 220.5(A). Voltages in excess of 250 volts to ground or 300 volts between phase conductors shall be permitted to be used only when the following conditions are met:

(1) The lighting shall be installed not less than 6.7 m (22 ft) above grade

- (2) Each pole, if of metal construction, shall be grounded by one of the approved methods
- (3) Disconnects shall be located within sight of the lights they control, outdoors, preferably on one of the poles
- (4) Where the installation is large or if the location of the lighting does not permit all the lighting to be within sight, more than one disconnect shall be permitted to be installed
- (5) Where snap-switches or push-button type switches are used, the voltage across these switches shall be reduced to less than 250 volts to ground or 300 volts between phase conductors
- (6) Branch circuits shall be limited to not more than 50 ampere rating
- (7) The electrical system shall be under the supervision of a supervising electrician."

14E-2-230 Services

The provisions of Article 230 of NFPA 70 are adopted by reference with the following modifications:

Revise subsection 230.30(B) to read:

"Wiring Methods. Underground service conductors shall be installed in accordance with the applicable requirements of this *Code* covering the type of wiring method used and shall be limited to the following:

- (1) Type RMC conduit
- (2) Type IMC conduit
- (3) Type HDPE conduit
- (4) Type PVC conduit
- (5) Type RTRC conduit"

Revise section 230.43 to read:

"Wiring Methods for 1000 Volts, Nominal, or Less. Service-entrance conductors shall be installed in accordance with the applicable requirements of this *Code* covering the type of wiring method used and shall be limited to the following methods:

- (1) Rigid metal conduit
- (2) Intermediate metal conduit
- (3) Service-entrance cables for existing residential occupancies of not more than three dwelling units.
- (4) Busways

(5) Cablebus

(6) Mineral-insulated, metal-sheathed cable.”

Revise section 230.46 to read:

“Spliced Conductors. Service entrance conductors shall only be spliced in accordance with 230.46 (1) through (6):

(1) Clamped or bolted connections in metering equipment enclosures

(2) Where service entrance conductors are tapped from a utility controlled and locked (to prevent unauthorized access) bussed tap box, to supply two to six disconnecting means grouped at a common location

(3) In an approved utility owned service splice box, where utility sized conductors are connected to conductors that supply customers service equipment and are sized to this chapter

(4) A connection shall be permitted where service conductors are extended from a service drop to an outside meter location and returned to connect to the service entrance conductors of an existing installation

(5) Where the service entrance conductors consist of busway, connections shall be permitted as required to assemble the various sections and fittings

(6) For existing service-entrance conductors, it shall be permissible to install listed underground splice kits for:

(a) Repair of existing conductors

(b) Extension of conductors by special permission.”

Revise subsection 230.70(A) to read:

“(A) Location. The service disconnecting means shall be installed in accordance with 230.70(A)(1), (A)(2), (A)(3), (A)(4), and (A)(5).

(1) One-Family and Two-Family Dwellings. In one- and two-family dwellings the service disconnecting means shall be installed at a readily accessible location in the basement or first floor of the building at a point not exceeding 1.52 m (5 ft) from the point of entry into the building. When the length of the service raceway exceeds 1.52 m (5 ft) from the point of entry into the building, the service raceway shall conform to the requirements of 230.6.

(2) In Other Than One- and Two-Family Dwellings. In other than one- and two-family dwellings, the service disconnecting means shall be installed at a readily accessible location either outside of the building or structure or inside the building or structure nearest the point of entrance of the service conductors. When the length of the service raceway exceeds 1.52 m (5 ft) from the point of entry into the building, the service raceway shall conform to the requirements of 230.6.

(3) Bathrooms. Service disconnecting means shall not be installed in bathrooms.

(4) Remote Control. Where a remote control device(s) is used to actuate the service disconnecting means, the service disconnecting means shall be located in accordance with 230.70(A)(1).

(5) High Rise Buildings. In high rise buildings and other similar buildings of large area, the disconnecting means for the multiple services recognized by 230.2(B)(2) shall be located in a dedicated fire-rated room as near as practical to the serving utility vault.

The rooms for the "main" service disconnecting means which serve the building common element loads shall have a 3-hour fire rating. The electrical service rooms for tenant loads shall have a 2-hour minimum fire rating. These rooms shall be for the exclusive use of electrical equipment.

Separate service disconnecting means shall be required for each tenant floor. These disconnects shall be permitted to be located on a floor other than the floor served. Where more than one service is permitted to serve one floor, the various disconnecting means and their locations shall be prominently identified as required by 230.2(E). All electrical service rooms shall comply with 110.26."

Insert the following language immediately before the exception in section 230.95:

"Where busway is served by a feeder or sequence service disconnect rated 1000 amperes or more, ground-fault protection of equipment shall be provided for solidly grounded wye electrical systems of any voltage."

14E-2-240 Overcurrent Protection

The provisions of Article 240 of NFPA 70 are adopted by reference with the following modification:

Insert the following language at the end of section 240.85 and before informational note:

"Circuit breakers and their enclosures shall be of such design that it will be impossible to substitute two or more circuit breakers in a space previously occupied by a lesser number of circuit breakers. Tandem circuit breakers shall not be permitted to be used as overcurrent devices."

14E-2-250 Grounding and Bonding

The provisions of Article 250 of NFPA 70 are adopted by reference with the following modifications:

Revise section 250.58 to read:

"Common Grounding Electrode System for High-Rise Buildings and Similar Buildings or Structures of Large Area. In high rise buildings and in similar buildings or structures that cover a large area, a common grounding electrode conductor, which will be considered an extension of the building grounding electrode, shall be permitted to be used as the required grounding electrode for all separately derived systems and

communications systems. The common grounding electrode conductor shall originate at an approved connection on the street side of the incoming metallic water pipe

Informational Note: See Figure 250.58 – Common Grounding Electrode System which is also known as Hogan Ground.

The common grounding electrode system installation shall comply with 250.58(A) through (C).

(A) Size. The common grounding electrode system conductor shall be sized in accordance with Table 250.66 based on the largest service or separately derived system using the common grounding electrode conductor. The minimum size of the common grounding electrode system conductor shall be 4/0 AWG copper installed in a 1¼" metal raceway permitted by 250.64(B). The maximum size of the common grounding electrode system conductor shall be 500 kcmil AWG copper installed in a 1½" metal raceway permitted by 250.64(B).

(B) Splices and Taps. The common grounding electrode conductor shall be continuous through its entire length. Where a splice is necessary, it shall be made by the use of listed irreversible compression connectors or exothermic welding. The tap connections shall be made to aluminum or copper busbars not smaller than ¼ in. × 2 in. If aluminum busbars are used, the installation shall comply with 250.64(A).

(C) Approved Metal Junction Boxes. All splices and taps of the common grounding electrode system conductor shall be made in and bonded to an approved metal junction box. The metal junction box shall be mounted on or bonded to the nearest available structural member of the building

Insert new figure 250.58 High Rise Common Ground Electrode System

[Remainder of Page Intentionally Left Blank]

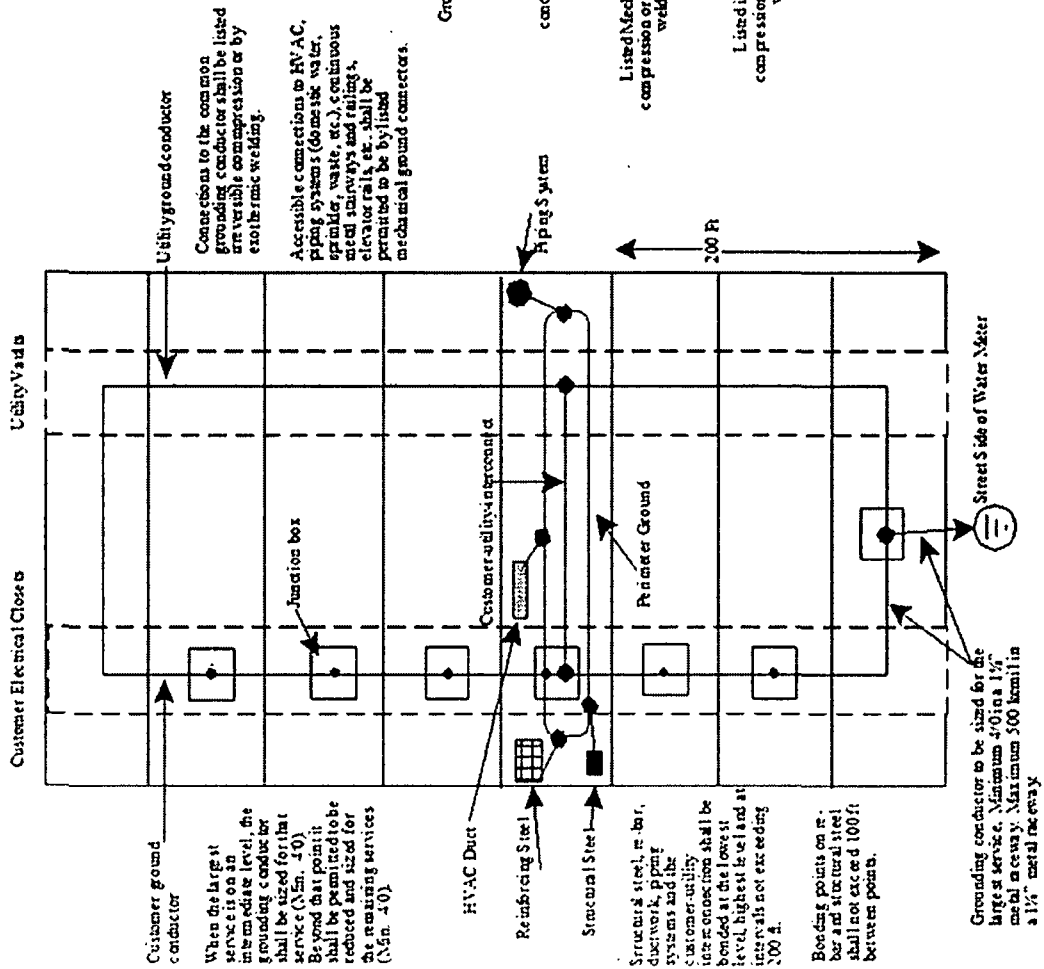
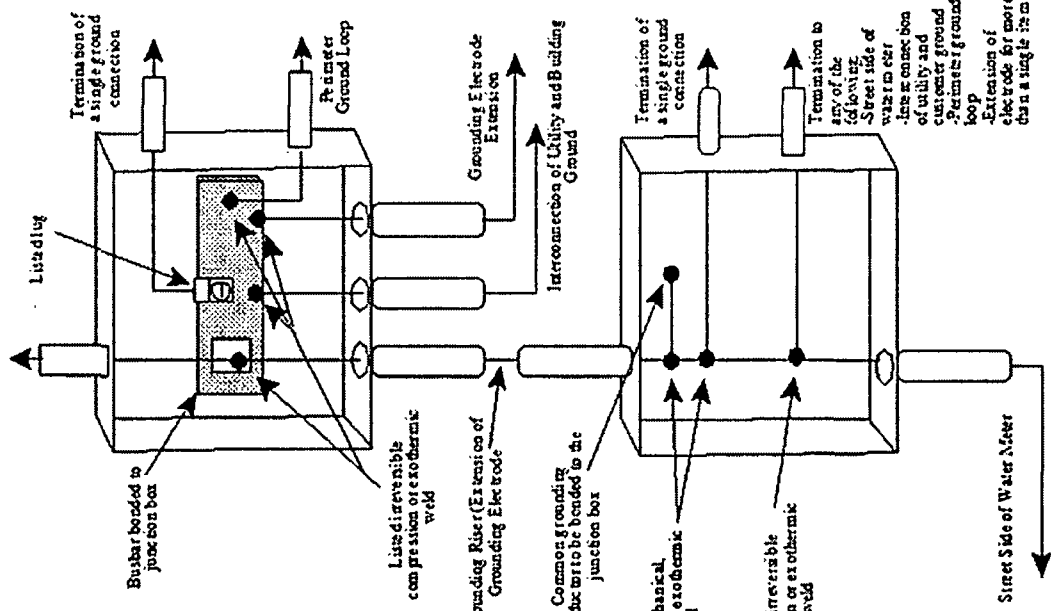

Utility ground conductor
 Connections to the common grounding conductor shall be listed or verifiable compression or by exothermic welding.
 Accessible connections to HVAC, piping systems (domestic water, sprinkler, waste, etc.), continuous metal stairways and railings, elevator rails, etc. shall be permitted to be by listed mechanical ground connectors.

Customer ground conductor
 When the largest service is on an immediate level, the grounding conductor shall be sized for that service (N.E.C. 40). Beyond that point it shall be permitted to be reduced and sized for the remaining services (N.E.C. 40).

Structural steel, rebar, ductwork, piping systems and the customer utility interconnection shall be bonded at the lowest level, highest to be listed at intervals not exceeding 200 ft.

Bonding points on rebar and structural steel shall not exceed 100 ft between points.

Grounding conductor to be sized for the largest service. Minimum #10 in a 1 1/2" metal raceway. Maximum 500 kcmil in a 1 1/2" metal raceway.

Revise subsection 250.64(B) to read, with no revisions to (B)(1) through B(4):

“Securing and Protection Against Physical Damage. Where exposed, a grounding electrode conductor or its enclosure shall be securely fastened to the surface on which it is carried. All grounding electrode conductors shall be installed in rigid metal conduit (RMC), intermediate metal conduit (IMC), or electrical metallic tubing (EMT). Raceways for grounding electrode conductors shall not contain other conductors.”

Revise subsection 250.64(C) to read:

“Continuous. Except as provided in 250.30(A)(5) and (A)(6), 250.30(B)(1), and 250.68(C), grounding electrode conductor(s) shall be installed in one continuous length without a splice or joint. If necessary, splices or connections shall be made as permitted in (1) through (2):

(1) Splicing of the wire-type grounding electrode conductor shall be permitted only by irreversible compression-type connectors listed as grounding and bonding equipment or by the exothermic welding process.

(2) Sections of busbars shall be permitted to be connected together to form a grounding electrode conductor.”

Revise the second paragraph of subsection 250.64(D)(1):

“A grounding electrode conductor tap shall extend to the inside of each service disconnecting means enclosure. The grounding electrode conductor taps shall be sized in accordance with 250.66 for the largest service-entrance conductor serving the individual enclosure. The tap conductors shall be connected to the common grounding electrode conductor by one of the following methods in such a manner that the common grounding electrode conductor remains without a splice or joint:

(1) Exothermic welding.

(2) Connectors listed as grounding and bonding equipment.

(3) Connections to an aluminum or copper busbar not less than ¼ in. × 2 in. The busbar shall be securely fastened in a metal box and shall be installed in an accessible location. Connections shall be made by a listed connector or by the exothermic welding process. If aluminum busbars are used, the installation shall comply with 250.64(A).”

Revise subsection 250.64(F)(3) to read:

“Bonding jumper(s) from grounding electrode(s) shall be permitted to be connected to an aluminum or copper busbar not less than ¼ in. thick × 2 in. wide and of sufficient length to accommodate the number of terminations necessary for the installation. The busbar shall be securely fastened and shall be installed in a metal box and at an accessible location. Connections shall be made by a listed connector or by the exothermic welding process. The grounding electrode conductor shall be permitted to be run to the busbar. Where aluminum busbars are used, the installation shall comply with 250.64(A).”

7. Revise Table 250.66 Service and Common Grounding for Alternating-Current Systems to read:

Size of Largest Service-Entrance Conductor or Equivalent for Parallel Conductor(s)		Size of Grounding Electrode Conductor and Conduit or Tubing			
Copper	Aluminum	Copper	Conduit or Tubing	Aluminum	Conduit or Tubing
Up to 2	Up to 1/0	8	½ in.	6	½ in.
Up to 1/0	Up to 3/0	6	½ in.	4	¾ in.
Up to 3/0	Up to 250	4	¾ in.	2	¾ in.
Up to 350	Up to 500	2	¾ in.	1/0	1 in.
Up to 600	Up to 900	1/0	1 in.	3/0	1 in.
Up to 1100	Up to 1750	2/0	1 in.	4/0	1 in.
Up to 1300	Up to 2000	3/0	1 in.	250	1¼ in.
Up to 1700	Up to 2400	4/0	1 in.	300	1¼ in.
Up to 1700	Up to 2800	250	1¼ in.	350	1¼ in.
Up to 2000	Up to 3200	300	1¼ in.	400	1½ in.
Up to 2400	Up to 4000	350	1¼ in.	500	1½ in.
Up to 2800	Up to 4800	400	1½ in.	600	2 in.
Up to 3200	Up to 5600	500	1½ in.	700	2 in.

14E-2-280 Surge Arresters, Over 1000 volts

The provisions of Article 280 of NFPA 70 are adopted by reference without modification.

14E-2-285 Surge Protective Devices (SPDs), 1000 volts or less

The provisions of Article 285 of NFPA 70 are adopted by reference without modification.

CHAPTER 14E-3 GENERAL REQUIREMENTS FOR WIRING METHODS AND MATERIALS

14E-3-300 General Requirements for Wiring Methods and Materials

The provisions of Article 300 of NFPA 70 are adopted by reference with the following modification:

Revise section 300.22 to read:

“Wiring in Ducts Not Used for Air-Handling, Fabricated Ducts for Environmental Air, Plenums, and Other Spaces for Environmental Air (Plenums). The provisions of this section apply to the installation and uses of electric wiring and equipment in ducts used for dust, loose stock, or vapor material; ducts specifically fabricated for environmental air; and other spaces used for environmental air (plenums).

Informational Note: See Article 424, Part VI, for duct heaters.

(A) Ducts for Dust, Loose Stock, or Vapor Removal. No wiring systems of any type shall be installed in ducts used to transport dust, loose stock, or flammable vapors. No wiring system of any type shall be installed in any duct, or shaft containing only such ducts, used for vapor removal or for ventilation of commercial-type cooking equipment.

(B) Ducts Specifically Fabricated for Environmental Air. Equipment, devices, and the wiring methods specified in this section shall be permitted within such ducts only if they are necessary for the direct action upon, or sensing of, the contained air. Where equipment or devices are installed and illumination is necessary to facilitate maintenance and repair, enclosed gasketed-type luminaires shall be required.

In ducts specifically fabricated to for environmental air, only the wiring methods consisting of the following shall be permitted:

- (1) Conductors or cables installed in electrical metallic tubing with gland nut type fittings, intermediate metal conduit or galvanized rigid metal conduit
- (2) Type MI Cable as permitted in Article 332
- (3) Type MC Cable employing a smooth or corrugated impervious metal sheath without an overall nonmetallic covering, as permitted in Article 330
- (4) Flexible metallic tubing as permitted in Article 360
- (5) Liquidtight flexible metal conduit in lengths not to exceed 1.22 m (4 ft), to connect physically adjustable equipment and devices permitted to be in these ducts.

(C) Other Space Used for Environmental Air (Plenums). This section shall apply to spaces not specifically fabricated for environmental air-handling purposes but used for air-handling purposes as a plenum. This section shall not apply to habitable rooms or areas of buildings, the prime purpose of which is not air handling.

Informational Note: The space over a hung ceiling used for environmental air-handling purposes and the space below a raised floor used for environmental air-handling purposes are examples of the type of other space to which this section applies.

Exception: This section shall not apply to the joist or stud spaces of dwelling units where the wiring passes through such spaces perpendicular to the long dimension of such spaces.

(1) Wiring Methods. The wiring methods for such other space shall be limited to the following:

- (a) Conductors or cables installed in electrical metallic tubing with gland nut type fittings, intermediate metal conduit or galvanized rigid metal conduit
- (b) Type MI Cable as permitted in Article 332
- (c) Type MC Cable employing a smooth or corrugated impervious metal sheath without an overall nonmetallic covering as permitted in Article 330
- (d) Flexible metallic tubing as permitted in Article 360
- (e) Liquidtight flexible metal conduit in lengths not to exceed 1.83 m (6 ft), to connect physically adjustable equipment and devices, other than lighting fixtures, permitted to be in these spaces.

(2) Luminaires and Electric Equipment. Electric equipment with a metal enclosure and no direct openings to the air space, and associated wiring material suitable for the ambient temperature shall be permitted to be installed in such other space unless prohibited elsewhere in this Code. Boxes shall have no holes and shall be provided with gasketed covers. Luminaires meeting these criteria and intended for use in this space shall be marked CCEA.

Informational Note 1: Criteria for CCEA (City of Chicago Environmental Air) may be obtained from Underwriters Laboratories.

Informational Note 2: This requirement is not intended to limit recessed fixtures that are constructed with tight seams and joints. Where so constructed no additional gasketing or sealing is required.

Exception: Integral fan systems specifically identified for such use.

(D) Information Technology Equipment. Electric wiring in air-handling areas benefit raised floors for information technology equipment shall be in accordance with 300.22(C) and Article 645.”

14E-3-310 Conductors for General Wiring

The provisions of Article 310 of NFPA 70 are adopted by reference with the following modifications:

1. Insert the following language immediately before informational note no. 1 in subsection 230.95 310.15(B)(3)(a):

“No more than nine current-carrying conductors shall be permitted to be installed in a raceway.”

Revise table 310.15(B)(3)(a) to read:

Number of Current-Carrying Conductors	Percent of Values in Table 310.15(B)(16) through Table 310.15(B)(19) as Adjusted for Ambient Temperature if Necessary
4-6	80
7-9	70

14E-3-312 Cabinets, Cutout Boxes, and Meter Socket Enclosures

The provisions of Article 312 of NFPA 70 are adopted by reference without modification.

14E-3-314 Outlets, Device, Pull and Junction Boxes, Conduit Bodies; Fittings; and Handhole Enclosures

The provisions of Article 314 of NFPA 70 are adopted by reference without modification.

14E-3-320 Armored Cable: Type AC

The provisions of Article 320 of NFPA 70 are adopted by reference with the following modifications:

Revise section 320.10 to read:

“Uses Permitted. Type AC cable shall be permitted to be installed as specified in 320.10(A) or (B).

(A) Existing Installations. Except where otherwise specified in this *Code* and where not subject to physical damage, listed Type AC cable with listed fittings and not exceeding 7.62 m (25 ft) in length between junction boxes shall be permitted to be installed for branch circuits in concealed work fished into existing walls, partitions, floors, or hard surface ceilings where other work does not require or include removal of the existing finished surface.

(B) Exposed Work. For exposed work only under the following conditions:

- (1) In lengths not more than 1.83 m (6 ft), at terminations where flexibility is necessary;
- (2) In lengths not more than 1.83 m (6 ft) in accessible, but not habitable, attics and roof spaces where installed in accordance with 320.12;
- (3) In lengths not greater than 1.83 m (6 ft), below the basement ceiling joists where it is necessary to connect a cabinet or junction box.”

Revise section 320.12 to read:

“Uses Not Permitted. Type AC cable shall not be used for any installation not permitted in 320.10.”

14E-3-322 Flat Cable Assemblies: Type FC

The provisions of Article 322 of NFPA 70 are not adopted.

14E-3-324 Flat Conductor Cable: Type FCC

The provisions of Article 324 of NFPA 70 are adopted by reference without modification.

14E-3-326 Integrated Gas Spacer Cable: Type IGS

The provisions of Article 326 of NFPA 70 are not adopted.

14E-3-328 Medium Voltage Cable: Type MV

The provisions of Article 328 of NFPA 70 are adopted by reference without modification.

14E-3-330 Metal-Clad Cable: Type MC

The provisions of Article 330 of NFPA 70 are adopted by reference with the following modifications:

Revise section 330.10 to read:

“Uses Permitted.

(A) Existing Installations. Except where otherwise specified in this *Code* and where not subject to physical damage, listed Type MC cable with listed fittings and not exceeding 7.62 m (25 ft) in length between junction boxes shall be permitted for branch circuits in concealed work fished into existing walls, partitions, floors, or hard surface ceilings where other work does not require or include removal of the existing finished surface.

(B) Exposed Work. For exposed work only under the following conditions:

- (1) In lengths not more than 1.83 m (6 ft), at terminations where flexibility is necessary;
- (2) In lengths not greater than 1.83 m (6 ft) in accessible, but not habitable, attics and roof spaces where installed in accordance with 320.23;
- (3) In lengths not greater than 1.83 m (6 ft), below the basement ceiling joists where it is necessary to connect a cabinet or junction box.”

Revise section 330.12 to read:

“Uses Not Permitted. Type MC cable shall not be used for any installation not permitted in 330.10.”

14E-3-332 Mineral-Insulated, Metal-Sheathed Cable: Type MI

The provisions of Article 332 of NFPA 70 are adopted by reference without modification.

14E-3-334 Nonmetallic-Sheathed Cable: Types NM, NMC, and NMS

The provisions of Article 334 of NFPA 70 are adopted by reference with the following modifications:

Revise section 334.10 to read:

“Uses Permitted. Type NM and Type NMC cables shall be permitted to be used in the following:

- (1) Temporary wiring for branch circuits as permitted in 590.4(C)
- (2) Temporary wiring as permitted for feeders as permitted in 590.4(B)
- (3) Limited extensions to knob-and-tube lighting or appliance branch circuits in existing dwelling units in buildings not exceeding three stories in height.”

Revise section 334.12 to read:

“Uses Not Permitted.

(A) Types NM, and NMC. Types NM and NMC cables shall not be used for any

installation not permitted in 334.10.

(B) Type NMS. Type NMS cables shall not be used.”

14E-3-336 Power and Control Tray Cable: Type TC

The provisions of Article 336 of NFPA 70 are adopted by reference with the following modifications:

Delete subsections 336.10(6) and (10).

Revise section 336.12 to read:

“Uses Not Permitted. Type TC tray cable shall not be installed or used as follows:

- (1) Installed where it will be exposed to physical damage
- (2) Installed outside a raceway or cable tray system
- (3) Used where exposed to direct rays of the sun, unless identified as sunlight resistant
- (4) Direct buried
- (5) Required fire alarm systems
- (6) In health care facilities, any patient communication or monitoring system”

14E-3-338 Service-Entrance Cable: Type SE and USE

The provisions of Article 338 of NFPA 70 are adopted by reference with the following modifications:

Revise section 338.10 to read:

“Uses Permitted.

(A) Service-Entrance Conductors. Service-entrance cable shall be permitted to be used as service-entrance conductors for buildings of non-transient residential occupancy containing not more than three dwelling units.

(B) Branch Circuits.

- (1) Branch Circuit Conductors. Type SE service-entrance cable shall be permitted for circuit wiring for electric ranges, electric hot water heaters, and electric clothes dryers.
- (2) Grounded Conductor Insulated. Type SE service-entrance cables shall be permitted in wiring systems where all of the circuit conductors of the cable are of the thermoset or thermoplastic type.
- (3) Use of Uninsulated Conductor. Type SE service-entrance cable without individual insulation on the grounded conductor shall not be permitted for branch circuit wiring.

(4) Temperature Limitations. Type SE service-entrance cable used to supply appliances shall not be subject to conductor temperatures in excess of the temperature specified for the type of insulation involved.

(5) Installation Methods for Cables. Cables shall be installed in accordance with (a) through (d) as listed below.

(a) Cable shall not be spliced, but shall be installed without interruption to the outlet

(b) Installation shall have approved and listed fittings

(c) In exposed installations, the cable shall follow closely follow the surface and be fastened at intervals not exceeding 450 mm (18 in.).

(d) In exterior installations, the cable shall be installed in a workman like manner in straight lines and a drip loop shall be provided”

Revise section 338.12 to read:

“Uses Not Permitted. Type SE and Type USE shall not be used for any installation not permitted in 338.10.”

14E-3-340 Underground Feeder and Branch-Circuit Cable: Type UF

The provisions of Article 340 of NFPA 70 are adopted by reference with the following modifications:

Revise section 340.10 to read:

“Uses Permitted. Listed Type UF cable shall be permitted as follows:

(1) For use underground, including direct burial in the earth. For underground requirements, see 300.5.

(2) As single-conductor cables. Where installed as single- conductor cables, all conductors of the feeder grounded conductor or branch circuit, including the grounded conductor and equipment grounding conductor, if any, shall be installed in accordance with 300.3.

(3) For solar photovoltaic systems in accordance with 690.31.

(4) As single-conductor cables as the non-heating leads for heating cables as provided in 424.43.

Informational Note: See 310.15(A)(3) for temperature limitation of conductors.”

14E-3-342 Intermediate Metal Conduit: Type IMC

The provisions of Article 342 of NFPA 70 are adopted by reference without modification.

14E-3-344 Rigid Metal Conduit: Type RMC

The provisions of Article 344 of NFPA 70 are adopted by reference without modification.

14E-3-348 Flexible Metal Conduit; Type FMC

The provisions of Article 348 of NFPA 70 are adopted by reference with the following modifications:

Revise section 348.10 to read:

“Uses Permitted. FMC shall be permitted to be used:

- (1) For the connection of motors or recessed luminaires
- (2) In lengths not exceeding 7.62 m (25 ft) between junction boxes for branch circuits in concealed work fished into existing walls, partitions, floors, or hard surface ceilings where other work does not require or include removal of the existing finished surface
- (3) For required flexibility at the termination of conduit runs.”

Insert new subsections 348.12(8) and (9) to read:

- “(8) In lengths exceeding 1.83 m (6 ft) except where fished in existing construction
- (9) Where exposed below the first floor except 1.83 m (6 ft) of any run shall be permitted to extend below the basement ceiling to connect to a cabinet, outlet box or junction box.”

14E-3-350 Liquidtight Flexible Metal Conduit: Type LFMC

The provisions of Article 350 of NFPA 70 are adopted by reference with the following modifications:

Delete subsection 350.10(3).

Insert new subsections 350.10(3) through (5) to read:

- “(3) For the connection of motors and recessed luminaires in a non-plenum ceiling
- (4) In lengths not exceeding 7.62 m (25 ft) between junction boxes for branch circuits in concealed work fished into existing walls, partitions, floors, or hard surface ceilings where other work does not require or include removal of the existing finished surface
- (5) For required flexibility at the terminations of conduit runs.”

Insert new subsections 350.12(3) through (7) to read:

- “(3) In hoistways, other than as permitted in 620.21(A)(1)
- (4) In storage battery rooms

(5) In any hazardous (classified) location except as permitted by other articles in this Code

(6) Where exposed to materials having a deteriorating effect on the installed conductors, such as oil or gasoline

(7) Underground or embedded in poured concrete or aggregate”

14E-3-352 Rigid Polyvinyl Chloride Conduit: Type PVC

The provisions of Article 352 of NFPA 70 are adopted by reference without modification.

14E-3-353 High Density Polyethylene Conduit: Type HDPE Conduit

The provisions of Article 353 of NFPA 70 are adopted by reference without modification.

14E-3-354 Nonmetallic Underground Conduit with Conductors: Type NUCC

The provisions of Article 354 of NFPA 70 are adopted by reference without modification.

14E-3-355 Reinforced Thermosetting Resin Conduit: Type RTRC

The provisions of Article 355 of NFPA 70 are adopted by reference without modification.

14E-3-356 Liquidtight Flexible Nonmetallic Conduit: Type LFNC

The provisions of Article 356 of NFPA 70 are not adopted.

14E-3-358 Electrical Metallic Tubing: Type EMT

The provisions of Article 358 of NFPA 70 are adopted by reference with the following modifications:

Insert the following language at the end of section 258.12:

“(3) For enclosing service entrance conductors”

14E-3-360 Flexible Metallic Tubing: Type FMT

The provisions of Article 360 of NFPA 70 are adopted by reference with the following modifications:

Revise subsections 360.10(1) through (4) to read:

“(1) Branch circuits not exceeding 20 amperes and 300 volts to ground

(2) As permitted in 300.22(C)

(3) Connection between a junction box and a single luminaire

(4) Connection between a junction box and speakers or similar equipment requiring flexibility”

Insert new subsection 360.12(7) to read:

“(7) Other than as specifically permitted in 360.10”

14E-3-362 Electrical Nonmetallic Tubing: Type ENT

The provisions of Article 362 of NFPA 70 are not adopted.

14E-3-366 Metallic Auxiliary Gutters

The provisions of Article 366 of NFPA 70 are adopted by reference with the following modifications:

Revise the title of Article 366 to “Metallic Auxiliary Gutters.”

Revise section 366.1 to read:

“**Scope.** This article covers the use, installation, and construction requirements of metal auxiliary gutters and associated fittings.”

Revise section 366.2 by deleting the definition of “Nonmetallic Auxiliary Gutter.”

Delete section 366.6.

Delete subsection 366.10(B).

Delete subsection 366.22(B).

Delete subsection 366.23(B).

Delete subsection 366.30(B).

Delete section 366.120.

14E-3-368 Busways

The provisions of Article 368 of NFPA 70 are adopted by reference without modification.

14E-3-370 Cablebus

The provisions of Article 370 of NFPA 70 are adopted by reference without modification.

14E-3-372 Cellular Concrete Floor Raceways

The provisions of Article 372 of NFPA 70 are not adopted.

14E-3-374 Cellular Metal Floor Raceways

The provisions of Article 374 of NFPA 70 are adopted by reference without modification.

14E-3-376 Metal Wireways

The provisions of Article 376 of NFPA 70 are adopted by reference with the following modification:

Revise section 376.12 by inserting new items (3) and (4) to read:

“(3) For service entrance conductors

(4) Above suspended ceilings”

14E-3-378 Nonmetallic Wireways

The provisions of Article 378 of NFPA 70 are not adopted.

14E-3-380 Multioutlet Assembly

The provisions of Article 380 of NFPA 70 are adopted by reference with the following modification:

Revise section 380.12 item (3) to read:

“(3) Where the voltage is 300 volts or more between conductors”

14E-3-382 Nonmetallic Extensions

The provisions of Article 382 of NFPA 70 are not adopted.

14E-3-384 Strut-Type Channel Raceway

The provisions of Article 384 of NFPA 70 are adopted by reference with the following modification:

Revise section 384.10 by inserting new item (8) to read:

“(8) Where the voltage is 600 volts or less.”

14E-3-386 Surface Metal Raceways

The provisions of Article 386 of NFPA 70 are adopted by reference with the following modification:

Revise section 386.12 by inserting new item (6) to read:

“(6) In any hazardous (classified) location”

14E-3-388 Surface Nonmetallic Raceways

The provisions of Article 388 of NFPA 70 are not adopted.

14E-3-390 Underfloor Raceways

The provisions of Article 390 of NFPA 70 are adopted by reference without modification.

14E-3-392 Cable Trays

The provisions of Article 392 of NFPA 70 are adopted by reference with the following modifications:

Revise section 392.10, excluding table 392.10(A), to read:

"Uses Permitted. Metal cable tray shall be permitted to be used as:

- (1) A support system for ac or dc power conductors 50 volts or less
- (2) For communications circuits, control circuits, and signaling circuits."

Revise subsection 392.12 to read:

"Uses Not Permitted. Cable tray systems shall not be used in the following:

- (1) Hoistways
- (2) Where subject to severe physical damage
- (3) Ducts and other spaces for environmental air subject (plenums) subject to 300.22
- (4) As a support system for ac or dc power conductors over 50 volts"

14E-3-393 Low-Voltage Suspended Ceiling Power Distribution Systems

The provisions of Article 393 of NFPA 70 are not adopted.

14E-3-394 Concealed Knob-and-Tube Wiring

The provisions of Article 394 of NFPA 70 are adopted by reference without modification.

14E-3-396 Messenger-Supported Wiring

The provisions of Article 396 of NFPA 70 are adopted by reference without modification.

14E-3-398 Open Wiring on Insulators

The provisions of Article 398 of NFPA 70 are not adopted.

14E-3-399 Outdoor Overhead Conductors over 1000 Volts

The provisions of Article 399 of NFPA 70 are adopted by reference without modification.

CHAPTER 14E-4 EQUIPMENT FOR GENERAL USE

14E-4-400 Flexible Cords and Cables

The provisions of Article 400 of NFPA 70 are adopted by reference without modification.

14E-4-402 Fixture Wires

The provisions of Article 402 of NFPA 70 are adopted by reference without modification.

14E-4-404 Switches

The provisions of Article 404 of NFPA 70 are adopted by reference with the following modification:

Revise subsection 404.14(D) to read:

Voltage. Snap switches shall not be used for the control of greater than 150V to ground circuits.

14E-4-406 Receptacles, Cord Connectors, and Attachment Plugs (Caps)

The provisions of Article 406 of NFPA 70 are adopted by reference without modification.

14E-4-408 Switchboard, Switchgear, and Panelboards

The provisions of Article 408 of NFPA 70 are adopted by reference with the following modifications:

Insert new section 408.11 to read:

"408.11 Special Services

(A) General. A special service switchboard or switchgear is defined as a switchboard or switchgear with a single disconnecting means having a frame rating in excess of 1200 amperes, or a sequence service switchboard where the sum of the frame sizes exceeds 1200 amperes. The following installation and construction shall apply to special service switchboards.

Informational Note: See 230.70 for permissible location(s) of the service disconnecting means.

(B) Drawing Submittal. The switchboard manufacturer who builds or assembles the special service equipment shall submit three sets of detailed drawings of the proposed equipment to the utility supply company. Upon acceptance, the utility shall retain one copy, stamp their acceptance and the available fault current, and forward them to the authority having jurisdiction.

The authority having jurisdiction shall review the drawings and notify the applicant of any changes, corrections, additions, or deletions required for approval. No switchboard shall be delivered or installed until the switchboard manufacturer has received approval from the authority having jurisdiction.

(C) Switchboard Rooms. The special service equipment shall be installed in a dedicated room of fire-resistant construction, accessible only to qualified persons. Where

subject to possible flooding, such as below grade, sump pumps shall be provided and floor mounted switchboards shall be installed on a concrete pad a minimum of 102 mm (4 in.) above the nominal floor level.

Switchboard rooms containing equipment rated 3000 amperes or greater shall have two or more means of egress. Egress personnel doors shall be equipped with suitable listed hardware to provide egress from the room.

(D) Ability to Withstand Fault Current. Such special service equipment shall be so designed, constructed, and assembled that it is capable of withstanding and interrupting the available fault current without damage to itself or its related equipment.

(E) Identification. All service and feeder disconnecting means shall be prominently identified by permanent means in accordance with 110.22.

(F) Barriers. All unprotected service bus shall be barriered or insulated to isolate the service busbars and terminals from the remainder of the switchboard. The exposed live or unprotected bus necessary to connect the line side of each switch shall be permitted to be un-isolated. The utility current transformers shall be in a barriered section conforming to the utility supply company requirements.

(G) Disconnecting Link. A disconnecting link shall be provided on the line side of the service switch or circuit breaker in the grounded conductor. Such link shall be located in the service switch or circuit breaker enclosure. In sequence switchboards, where each switch is permitted to have its own neutral disconnecting link, the location of the disconnecting link shall be provided on the switchboard cover.

(H) Bus Ampacity.

(1) Service entrance conductors and bus work on the line side of the service entrance switch(es) or circuit breaker(s) shall have an ampacity sufficient to carry the load supplied but shall not be less than 80% of the total rating of the service switch(es) or the frame size of the circuit breaker or breakers.

(2) When 100% rated switches or circuit breakers are used as the service disconnecting means, service entrance conductors and bus work shall have a rating of not less than 100% of the total rating of the service switch(es).

(3) Each switch or circuit breaker of the assembly shall be supplied by bus having an ampacity equal to the full rating of the switch or circuit breaker.

(I) Smallest Size Switch. Switches or circuit breakers need not be the same size; however, no switch or circuit breaker is permitted to be smaller than 400 amperes.

Exception No. 1: For a small emergency lighting load a switch sufficient in size for the load shall be permitted to be used. Such switch shall be mounted in the switchboard and shall be considered one of the six service disconnects.

Exception No. 2: On a sequence switchboard where the sum of the switches does not exceed 2400 amperes, 200 amperes shall be the minimum frame size.

(J) Maximum Electrical AC Service Size. The ampacity of any switchboard, switchgear or electrical ac service shall be limited to 4000 amperes. The maximum rating of any service disconnecting means shall be 3000 amperes. In a sequence service, which is a service with up to six disconnects, the sum of the disconnecting means shall not exceed 5000 amperes and no single disconnect shall exceed 3000 amperes. If the capacity requirements of an installation exceeds 4000 amperes, provisions for two or more electrical ac services shall be made.

(K) Complete Metal Enclosure. The switchboard or switchgear shall have a complete metal enclosure including bottom plates.

Exception: The bottom plates shall be permitted to be omitted when the switchboard is installed in a dedicated room of fire-resistant construction on a concrete pad where there is no opening between the walls of the switchboard and the pad. The conduit entries shall conform to 408.5 and shall be bonded as required by 250.94.

(L) Conduit Entries. All conduit entries to the ac service switchboard or switchgear shall have bonding bushings and their straps shall terminate on the bonding bus. Conduit entries to the switchboard or switchgear enclosure shall not be made within 10 in. of any live switchboard bus. Service entrance raceways shall enter the switchboard only in the service switch, cable transition, or current transformer sections. No other conductors shall pass through these sections. Feeder conduits and conductors shall terminate in the switchboard section from which they are supplied.

(M) Header Boxes. Header boxes shall contain not more than 30 conductors at any cross section and shall comply with 314.28(B). All header boxes shall be of the same construction as the switchboard.

(N) Bottom Boxes.

(1) Concrete gutters or trenches under switchboards or switchgear shall not be permitted.

(2) An under-switchboard or switchgear trench or gutter, in a dry location, lined with metal of the proper gauge to form an approved bottom box, and which is properly bonded to the switchboard or switchgear to form a complete enclosure shall be permitted. All conduit entries to this bottom box shall comply with (l) of this subsection.

Informational Note: A concrete slab in contact with the earth, or on the lowest level of a building is not a dry location.

(3) Where a bottom box is allowed in a wet location, the installation is subject to special review by the authority having jurisdiction. Complete drawings of the installation shall be submitted with the switchboard submittal, along with a request for special permission. A means to drain any accumulated moisture shall be provided.

(O) Maintenance. Required maintenance for special service equipment shall conform to 408.4.”

The provisions of Article 409 of NFPA 70 are adopted by reference without modification.

14E-4-410 Luminaires, Lampholders, and Lamps

The provisions of Article 410 of NFPA 70 are adopted by reference without modification.

14E-4-411 Low Voltage Lighting

The provisions of Article 411 of NFPA 70 are adopted by reference with the following modification:

Revise section 411.3 to read:

“Low-Voltage Lighting Systems.

(A) General. Lighting systems operating at 30 volts ac or 60 dc shall consist of an isolating power supply, the low-voltage luminaires, and associated equipment that are all identified for the use. The output circuits of the power supply shall be rated for 25 amperes maximum under all load conditions.

(B) Class 2. Listed Class 2 lighting equipment shall be rated in conformance with Chapter 9, Table 11(A) or Table 11(B).”

14E-4-422 Appliances

The provisions of Article 422 of NFPA 70 are adopted by reference without modification.

14E-4-424 Fixed Electric Space-Heating Equipment

The provisions of Article 424 of NFPA 70 are adopted by reference without modification.

14E-4-425 Fixed Resistance and Electrode Industrial Process Heating Equipment

The provisions of Article 425 of NFPA 70 are adopted by reference without modification.

14E-4-426 Fixed Outdoor Electric De-icing and Snow-Melting Equipment

The provisions of Article 426 of NFPA 70 are adopted by reference without modification.

14E-4-427 Fixed Electric Heating Equipment for Pipeline and Vessels

The provisions of Article 427 of NFPA 70 are adopted by reference without modification.

14E-4-430 Motors, Motor Circuits, and Controllers

The provisions of Article 430 of NFPA 70 are adopted by reference without modification.

14E-4-440 Air-Conditioning and Refrigeration Equipment

The provisions of Article 440 of NFPA 70 are adopted by reference without modification.

14E-4-445 Generators

The provisions of Article 445 of NFPA 70 are adopted by reference without modification.

14E-4-450 Transformers and Transformer Vaults (Including Secondary Ties)

The provisions of Article 450 of NFPA 70 are adopted by reference with the following modification:

Revise section 450.14 to read:

“Disconnecting Means. Transformers, other than Class 2 or Class 3 transformers, shall have a disconnecting means for the secondary side that is located in sight of the transformer and shall conform to the requirements in Part VI of Article 230. The disconnecting means shall be lockable in accordance with 110.25.”

14E-4-455 Phase Converters

The provisions of Article 455 of NFPA 70 are adopted by reference without modification.

14E-4-460 Capacitors

The provisions of Article 460 of NFPA 70 are adopted by reference without modification.

14E-4-470 Resistors and Reactors

The provisions of Article 470 of NFPA 70 are adopted by reference without modification.

14E-4-480 Storage Batteries

The provisions of Article 480 of NFPA 70 are adopted by reference without modification.

14E-4-490 Equipment Over 1000 Volts, Nominal

The provisions of Article 490 of NFPA 70 are adopted by reference without modification.

CHAPTER 14E-5 SPECIAL OCCUPANCIES

14E-5-500 Hazardous (Classified) Locations, Classes I, II, and III, Divisions 1 And 2

The provisions of Article 500 of NFPA 70 are adopted by reference without modification.

14E-5-501 Class I Locations

The provisions of Article 501 of NFPA 70 are adopted by reference with the following modifications:

Revise subsections 501.10(A)(1) and (A)(2) to read:

“(1) General. In Class I, Division 1 locations, the wiring methods in (a) through (c) shall

be permitted.

- (a) Threaded rigid metal conduit or threaded steel intermediate metal conduit.
- (b) Type MI cable terminated with fittings listed for the location. Type MI cable shall be installed and supported in a manner to avoid tensile stress at the termination fittings.
- (c) Optical fiber cable Types OFNP, OFCP, OFNR, OFCR, OFNG, OFCG, OFN and OFC shall be permitted to be installed in raceways in accordance with 501.10(A). These optical fiber cables shall be sealed in accordance with 501.15.

(2) Flexible Connections. Where necessary to employ flexible connections, as at motor terminals, one of the following shall be permitted:

- (1) Flexible fittings listed for the locations
- (2) Flexible cord in accordance with the provisions of 501.140, terminated with cord connectors listed for the location."

Revise subsections 501.10(B)(1) and (B)(2) to read:

"(1) General. In Class I, Division 2 locations, the following wiring methods shall be permitted:

- (1) All wiring methods permitted in 501.10(A).
- (2) Enclosed gasketed busways and enclosed gasketed wireways.
- (3) Type PLTC and Type PLTC-ER cable in accordance with the provisions of Article 725. The cable shall be terminated with listed fittings.
- (4) Type MV and the cable shall be terminated with listed fittings.
- (5) Optical fiber cable Types OFNP, OFCP, OFNR, OFCR, OFNG, OFCG, OFN, and OFC shall be permitted to be installed in any raceway in accordance with 501.10(B). Optical fiber cables shall be sealed in accordance with 501.15.

(2) Flexible Connections. Where provision must be made for limited flexibility, one or more of the following shall be permitted:

- (1) Listed flexible metal fittings.
- (2) Flexible metal conduit with listed fittings.
- (3) Liquidtight flexible metal conduit with listed fittings.
- (4) Flexible cord listed for extra-hard usage and terminated with listed fittings. A conductor for use as an equipment grounding conductor shall be included in the flexible cord.
- (5) For elevator use, an identified elevator cable of Type EO, ETP, or ETT, shown under the "use" column in Table 400.4 for "hazardous (classified) locations" and terminated

with listed fittings.

Informational Note: See 501.30(B) for grounding requirements where flexible conduit is used.”

14E-5-502 Class II Locations

The provisions of Article 502 of NFPA 70 are adopted by reference with the following modifications:

Revise subsections 502.10(A)(1) and (A)(2) to read:

“(1) General. In Class II, Division 1 locations, the wiring methods in (1) through (4) shall be permitted:

- (1) Threaded rigid metal conduit, or threaded steel intermediate metal conduit.
- (2) Type MI cable with termination fittings listed for the location. Type MI cable shall be installed and supported in a manner to avoid tensile stress at the termination fittings.
- (3) Optical fiber cable Types OFNP, OFCP, OFNR, OFCR, OFNG, OFCG, OFN, and OFC shall be permitted to be installed in raceways in accordance with 502.10(A). Optical fiber cables shall be sealed in accordance with 502.15.

(2) Flexible Connections. Where necessary to employ flexible connections, one or more of the following shall also be permitted:

- (1) Dusttight flexible connectors.
- (2) Liquidtight flexible metal conduit with listed fittings.
- (3) Interlocked armor Type MC cable having an overall jacket of suitable polymeric material and provided with termination fittings listed for Class II, Division 1 locations.
- (4) Flexible cord listed for extra-hard usage and terminated with listed dusttight fittings. Where flexible cords are used, they shall comply with 502.140.

Informational Note: See 502.30(B) for grounding requirements where flexible conduit is used.”

Revise subsections 502.10(B)(1) and (B)(2) to read:

“(1) General. In Class II, Division 2 locations, the following wiring methods shall be permitted:

- (1) All wiring methods permitted in 502.10(A).
- (2) Rigid metal conduit, intermediate metal conduit, electrical metallic tubing, dusttight wireways.
- (3) Type MI cable with listed termination fittings.

(4) Type PLTC and Type PLTC-ER cable in accordance with the provisions of Article 725, including installation in cable tray systems. The cable shall be terminated with listed fittings.

(5) Type ITC and Type ITC-ER cable as permitted in 727.4 and terminated with listed fittings.

(6) Type MI, MV, TC, or TC-ER cable installed in ladder, ventilated trough, or ventilated channel cable trays in a single layer, with a space not less than the larger cable diameter between the two adjacent cables, shall be the wiring method employed.

(7) Optical fiber cable Types OFNP, OFCP, OFNR, OFCR, OFNG, OFCG, OFN, and OFC shall be permitted to be installed in cable trays or any other raceways in accordance with 502.10(A). Optical fiber cables shall be sealed in accordance with 502.15

(2) Flexible Connections. Where provision must be made for flexibility, 502.10(A)(2) shall apply.”

14E-5-503 Class III Locations

The provisions of Article 503 of NFPA 70 are adopted by reference with the following modifications:

Revise subsections 503.10 (A)(1) to (A)(3) to read:

(1) General. In Class III, Division 1 locations, the wiring method shall be in accordance with (1) through (4):

(1) Rigid metal conduit, Type RTRC conduit, intermediate metal conduit, electrical metallic tubing, dusttight wireways, or Type MI cable with listed termination fittings.

(2) Type PLTC and Type PLTC-ER cable in accordance with the provisions of Article 725 including installation in cable tray systems. The cable shall be terminated with listed fittings.

(3) Type ITC and Type ITC-ER cable as permitted in 727.4 and terminated with listed fittings.

(2) Boxes and Fittings. All boxes and fittings shall be dusttight.

(3) Flexible Connections. Where necessary to employ flexible connections, one or more of the following shall be permitted:

(1) Dusttight flexible connectors

(2) Liquidtight flexible metal conduit with listed fittings,

(3) Interlocked armor Type MC cable having an overall jacket of suitable polymeric material and installed with listed dusttight termination fittings

(4) Flexible cord in compliance with 503.140

Informational Note: See 503.30(B) for grounding requirements where flexible conduit is used.

(5) For elevator use, an identified elevator cable of Type EO, ETP, or ETT, shown under the “use” column in Table 400.4 for “hazardous (classified) locations” and terminated with listed dusttight fittings.”

Revise subsection 503.10(B) to read:

“**Class III, Division 2.** In Class III, Division 2 locations, the wiring method shall comply with 503.10(A).”

14E-5-504 Intrinsically Safe Systems

The provisions of Article 504 of NFPA 70 are adopted by reference without modification.

14E-5-505 Zone 0, 1, and 2 Locations

The provisions of Article 505 of NFPA 70 are adopted by reference without modification.

14E-5-506 Zone 20, 21, and 22 Locations for Combustible Dusts or Ignitable Fibers/Flyings

The provisions of Article 506 of NFPA 70 are adopted by reference with the following modifications.

Revise subsection 506.15(A) by deleting items (3) and (4).

Revise subsection 506.15(C) item (3) to read:

“Type MC cable with listed termination fittings.”

Revise subsection 506.15(C) by deleting items (4), (5), and (6).

14E-5-510 Hazardous (Classified) Locations - Specific

The provisions of Article 510 of NFPA 70 are adopted by reference without modification.

14E-5-511 Commercial Garages, Repair and Storage

The provisions of Article 511 of NFPA 70 are adopted by reference with the following modifications:

Revise subsection 511.7(A)(1) to read:

“**Fixed Wiring Above Class I Locations.** All fixed wiring above Class I locations shall be in metal raceways, flexible metal conduit, liquidtight flexible metal conduit, or shall be Type MI, or PLTC cable in accordance with Article 725, or Type TC cable or Type ITC cable in accordance with Article 727.”

Revise section 511.8 to read:

“Underground Wiring. Underground wiring shall be installed in threaded rigid metal conduit or threaded intermediate metal conduit.”

14E-5-513 Aircraft Hangars

The provisions of Article 513 of NFPA 70 are adopted by reference with the following modification:

Revise subsection 513.7(A) to read:

“Fixed Wiring. All fixed wiring in a hangar but not installed in a Class I location as classified in 513.3 shall be installed in metal raceways or shall be Type MI cable.”

14E-5-514 Motor Fuel Dispensing Facilities

The provisions of Article 514 of NFPA 70 are adopted by reference with the following modification:

Revise section 514.8 to delete Exception No. 1 and Exception No. 2 in their entirety.

14E-5-515 Bulk Storage Plants

The provisions of Article 515 of NFPA 70 are adopted by reference with the following modifications:

Revise subsection 515.7(A) to read:

“Fixed Wiring. All fixed wiring above Class I locations shall be in metal raceways, or Type MI, Type TC, or Type PLTC and Type PLTC-ER cable in accordance with the provisions of Article 725, or Type ITC and Type ITC-ER cable as permitted in 727.4. The cable shall be terminated with listed fittings.”

Revise subsection 515.8(A) to read:

“Wiring Method. Underground wiring shall be installed in threaded rigid metal conduit or threaded steel intermediate metal conduit.”

Delete subsection 515.8(C) in its entirety.

14E-5-516 Spray Application, Dipping, Coating, and Printing Processes Using Flammable or Combustible Materials

The provisions of Article 516 of NFPA 70 are adopted by reference with the following modifications:

Revise subsection 516.7(A) to read:

“Wiring. All fixed wiring above the Class I and II locations shall be in metal raceways; where cables are used, they shall be Type MI or Type TC. Cellular metal floor raceways

shall only be permitted to supply ceiling outlets or as extensions to the area below the floor of a Class I or II location. Where cellular metal floor raceways are used, they shall not have connections leading into or passing through the Class I or II location unless suitable seals are provided.”

Revise subsection 516.38(A) to read:

“**Wiring.** All fixed wiring above the Class I and II locations shall be in metal raceways; where cables are used, they shall be Type MI or Type TC cable. Cellular metal floor raceways shall only be permitted to supply ceiling outlets or as extensions to the area below the floor of a Class I or II location. Where cellular metal raceways are used, they shall not have connections leading into or passing through the Class I or II location unless suitable seals are provided.”

14E-5-517 Health Care Facilities

The provisions of Article 517 of NFPA 70 are adopted by reference with the following modifications:

Revise the definition of “Battery-Powered Lighting Units” in section 517.2 to read:

“Individual unit equipment for required standby emergency illumination shall consist of the following:

- (1) Rechargeable acid or alkali storage battery designed and constructed to meet the requirements of emergency service of suitable rating and capacity to supply and maintain not less than 87½ percent of the nominal battery voltage for the total lamp load associated with the unit for a period of at least 90 minutes
- (2) Battery-charging means
- (3) Provisions for one or more lamps mounted on the equipment, or with terminals for remote lamps, or both
- (4) Relaying device arranged to energize the lamps automatically upon failure of the supply to the unit equipment
- (5) Unit battery housing and lamp housing shall be made of metal

All unit battery equipment shall be listed and labeled as emergency lighting equipment.”

Revise the definition of “Critical Branch” in section 517.2 to read:

“A subsystem of the emergency system consisting of feeders and branch circuits supplying power for task illumination, fixed equipment, select receptacles, and select power circuits serving areas and functions related to patient care that are automatically connected to alternate power sources by one or more transfer switches during interruption of normal power source.”

Insert the following language in section 517.2 after the definition of “Equipment branch”:

“**Equipotential Grounding System.** A grounding system in which all exposed conductive surfaces are connected to a common grounding point by approved conductors to insure that all surfaces are at the same potential.”

Revise the definition of “Life Safety Branch” in section 517.2 to read:

“A subsystem of the emergency system consisting of feeders and branch circuits, meeting the requirements of Article 700 and intended to provide adequate power needs to ensure safety to patients and personnel, and that is automatically connected to alternate power sources by two or more transfer switches during interruption of the normal power source.”

Revise the definition of “Reference Grounding Point” in section 517.2 to read:

“A ground terminal or group of terminals which serve as a collection point for grounding exposed metal of conductive building surfaces in a patient care room.”

Revise the definition of “Selected Receptacles” in section 517.2 to read:

“A minimum number of electrical receptacles to accommodate appliances ordinarily required for local tasks or likely to be used in patient care emergencies. Selected receptacles shall be identified by means of red coloring and be hospital grade receptacles which are fed from a branch circuit connected on the critical branch.”

Revise the definition of “Task Illumination” in section 517.2 to read:

“Provisions for the minimum lighting required to carry out necessary tasks in the described areas, including safe access to supplies and equipment. Task illumination branch circuit shall be fed from critical branch.”

Revise section 517.13 to read:

“Grounding of Receptacles and Fixed Electrical Equipment in Patient Care Spaces. Wiring in patient care spaces shall comply with 517.13(A) and (B).

(A) Wiring Methods. All branch circuits serving patient care spaces shall be provided with an effective ground-fault current path by installation in a metal raceway system. The metal raceway system shall itself qualify as an equipment grounding conductor in accordance with 250.118.

(B) Insulated Equipment Grounding Conductors and Insulated Equipment Bonding Jumpers.

(1) General. The following shall be directly connected to an insulated copper equipment grounding conductor that is clearly identified along its entire length by green insulation and installed with the branch circuit conductors in the wiring methods as provided in 517.13(A).

(1) The grounding terminals of all receptacles other than isolated ground receptacles.

(2) Metal outlet boxes, metal device boxes, or metal enclosures containing receptacles.

(3) All non-current-carrying conductive surfaces of fixed electrical equipment likely to become energized that are subject to personal contact, operating at over 100 volts.

Exception No. 1: For other than isolated ground receptacles, an insulated equipment bonding jumper that directly connects to the equipment grounding conductor is permitted to connect the box and receptacle(s) to the equipment grounding conductor. Isolated ground receptacles shall be connected in accordance with 517.16.

Exception No.2: Metal faceplates shall be permitted to be connected to the equipment grounding conductor by means of a metal mounting screw(s) securing the faceplate to a grounded outlet box or grounded wiring device.

Exception No.3: Luminaires more than 2.29 m (7.5 ft) above the floor and switches located outside of the patient care vicinity shall be permitted to be connected to an equipment grounding return path complying with 517.13(A) or (B).

(2) Sizing. Equipment grounding conductors and equipment bonding jumpers shall be sized in accordance with 250.122.”

Revise section 517.14 to read:

“Panelboard Bonding. The equipment grounding terminal buses of the normal and essential branch-circuit panelboards serving the same individual patient care vicinity shall be connected together with an insulated continuous copper conductor not smaller than 6 AWG. Where two or more panelboards serving the same individual patient care vicinity are served from separate transfer switches on the emergency system, the equipment grounding terminal buses of those panelboards shall be connected together with an insulated continuous copper conductor not smaller than 6 AWG. This conductor shall be permitted to be broken in order to terminate on the equipment grounding terminal bus in each panelboard.”

Revise section 517.16 to read:

“Receptacles with Isolated Grounding Terminals. Receptacles with isolated grounding terminals, as described in 250.146(D), shall be identified by color coding the receptacle orange and shall not be used within patient care space.”

Revise the first paragraph of subsection 517.18(A) to read:

“Patient Bed Location. Each patient bed location shall be supplied by at least two branch circuits, one from the emergency system critical branch and one from the normal system. All branch circuits from the normal system shall originate in the same panelboard. The electrical receptacles supplied from the critical branch shall be identified by means of red coloring and shall also indicate the panelboard and branch-circuit number supplying them. Branch circuits serving patient bed locations shall not be part of a multi-wire branch circuit.”

Revise subsection 517.19(D) to read:

“Patient Care Vicinity Grounding and Bonding. All critical care (Category 1) space shall have an equipotential grounding system. An equipotential grounding system shall consist of grounding and bonding conductors connected to ground bars and arranged to maintain voltage potential differences at a safe level in the patients’ vicinity between all conductive surfaces, all conductive non-electrical equipment and devices and all non-

current carrying metal parts of electrical equipment and devices.

(1) Bonding and Grounding Conductors. All bonding and grounding conductors shall be green insulated, stranded copper, installed in metal raceways in continuous length, without splice from, ground bar to ground bar. The minimum size of the grounding and bonding conductor shall be as follows:

(a) From source of power (main electrical service or transformer) to the distribution panelboards or panels serving the branch circuit panelboards in the areas required to have equipotential grounding shall be sized in accordance with 250.122 with a minimum size of 6 AWG.

(b) From the distribution panelboard to the branch circuit panelboard and to the patients' panelboard, when used, shall be sized in accordance with 250.122 with minimum size of 6 AWG.

(c) To the room, reference or patient ground buses or between these the minimum size shall be 6 AWG.

(d) To non-electric conductive surfaces and ground jacks shall be 10 AWG

(e) To receptacles, light switch boxes, and luminaires shall be 12 AWG.

(f) To additional ground jack devices shall be 10 AWG.

(g) Between panelboards supplying the same patient shall be 6 AWG.

(h) Grounding electrical cordage shall be 10AWG extra-flex.

(i) All metal raceways in the aforementioned spaces containing electrical wiring shall have at least one equipment grounding conductor sized to Table 250.122.

(j) Each distribution panelboard and branch circuit panelboard supplying power to an area that requires potential grounding shall contain and equipotential ground bar. All ground bars shall be bonded to the enclosure in approved manner. All grounding bars shall be made of copper, not less than ¼ in. thick, drilled and tapped for ¼ in. x 20 machine screw and sized large enough to accommodate all the conductors to be connected plus spares. Each conductor shall be connected by a separate ¼ in. x 20 hexhead, non-slotted machine screw. All connections shall be torqued in accordance with 110.14(D).

(2) Critical Care (Category 1) Bed Location. Each critical care (Category 1) bed location shall have equipment grounding point grounded by means of an insulated continuous copper conductor, sized not smaller 6 AWG installed directly to the reference grounding point or to an equipment grounding bus of the panelboard serving the critical care (Category 1) patient. The patient equipment grounding point shall contain a minimum of 4 listed ground jacks and additional listed ground jacks shall be installed as required.

(3) Fixed Exposed Conductive Surfaces. Fixed exposed conductive surfaces in the critical care (Category 1) vicinity shall be connected to the critical care bonding point(s)

or reference grounding point by a continuous 10 AWG copper conductor.

Exception: Small wall-sized conductive surfaces such as surface-mounted towel and soap dispensers, mirrors, and so forth shall not be required to be grounded. In addition, bedside stands, over-bed tables, chairs, portable IV poles, and small, portable nonelectrical devices such as trays, pitchers, bedpans and the like, shall not be required to be grounded.

(4) Single Point. Any other grounding and bonding points in 517.19(D)(2) and (D)(3) shall be permitted to be combined into a single point."

Revise section 517.25 by deleting the informational note.

Revise section 517.29 to read:

"Essential Electrical Systems for Hospitals.

(A) Applicability. The requirements of Part III, 517.29 through 517.35, shall apply to hospitals where an essential electrical system is required.

Health care facilities other than hospitals with critical care (category 1) spaces shall also comply with these requirements.

(B) General.

(1) Scope. Essential electrical systems for hospitals shall be comprised of two separate systems capable of supplying a limited amount of lighting and power service, which is considered essential for life safety and effective hospital operation during the time the normal electrical service is interrupted for any reason. These two systems shall be the emergency system and the equipment system.

(2) Emergency System. The emergency system shall be limited to circuits essential to life safety and critical patient care. These are designated the life safety branch and the critical branch.

(3) Equipment System. The equipment system shall supply major electric equipment necessary for patient care and basic hospital operation.

(4) Transfer switches. The number of transfer switches to be used shall be based upon design and load considerations. Each branch of the essential electrical system shall be served by one or more transfer switches as shown in Figures 517.29(B)(4)(a). With special permission, facilities with a maximum demand on the essential electrical system of 150 kVA will be permitted to have one transfer switch serving the emergency branches as in Figure 517.29(B)(4)(b).

(5) Other Loads. Loads served by the generating equipment not specifically named in 517.33 and 517.34 shall be served by their own transfer switches such that these loads:

(1) Shall not be transferred if the transfer will overload the generating equipment

(2) Shall be automatically shed upon generating equipment overloading.

(6) Power source. Hospital power sources and alternate power sources shall be permitted to serve the essential systems of contiguous or same site facilities.

(C) Wiring Requirements.

(1) Separation from Other Circuits. The life safety branch and critical branch of the emergency system shall be kept entirely independent of all other wiring and equipment and shall not enter the same raceways, boxes, or cabinets with each other or other wiring.

Exception: Service switchboard and transfer switch equipment.

(2) Isolated Power Systems. Where isolated power systems are installed in any of the areas in 517.33(A)(1) and (A)(2), each system shall be supplied by an individual circuit serving no other load.

(3) Mechanical Protection of the Emergency System. The wiring of the emergency system of a hospital shall be mechanically protected by installation in non-flexible metal raceways, or shall be wired with Type MI cable. Where installed as branch circuit conductors serving patient care areas, the installation shall comply with the requirements of 517.13.

Exception: Flexible power cords of appliances, or other utilization equipment, connected to the emergency system shall not be required to be enclosed in raceways.

Informational Note: See 517.13(B) for additional grounding requirements in patient care areas.

(D) Capacity of Systems. The essential electrical system shall have adequate capacity to meet the demand for the operation of all functions and equipment to be served by each system and branch.

Feeders shall be sized in accordance with Articles 215 and 220. The generator set(s) shall have sufficient capacity and proper rating to meet the demand produced by the load of the essential electrical system(s) at any one time.

Demand calculations for sizing of the generator set(s) shall be based upon one or more of the following:

- (1) Prudent demand factors and historical data
- (2) Connected load
- (3) Feeder calculation procedures described in Article 220"

Insert Figure 517.29(B)(4)(a):

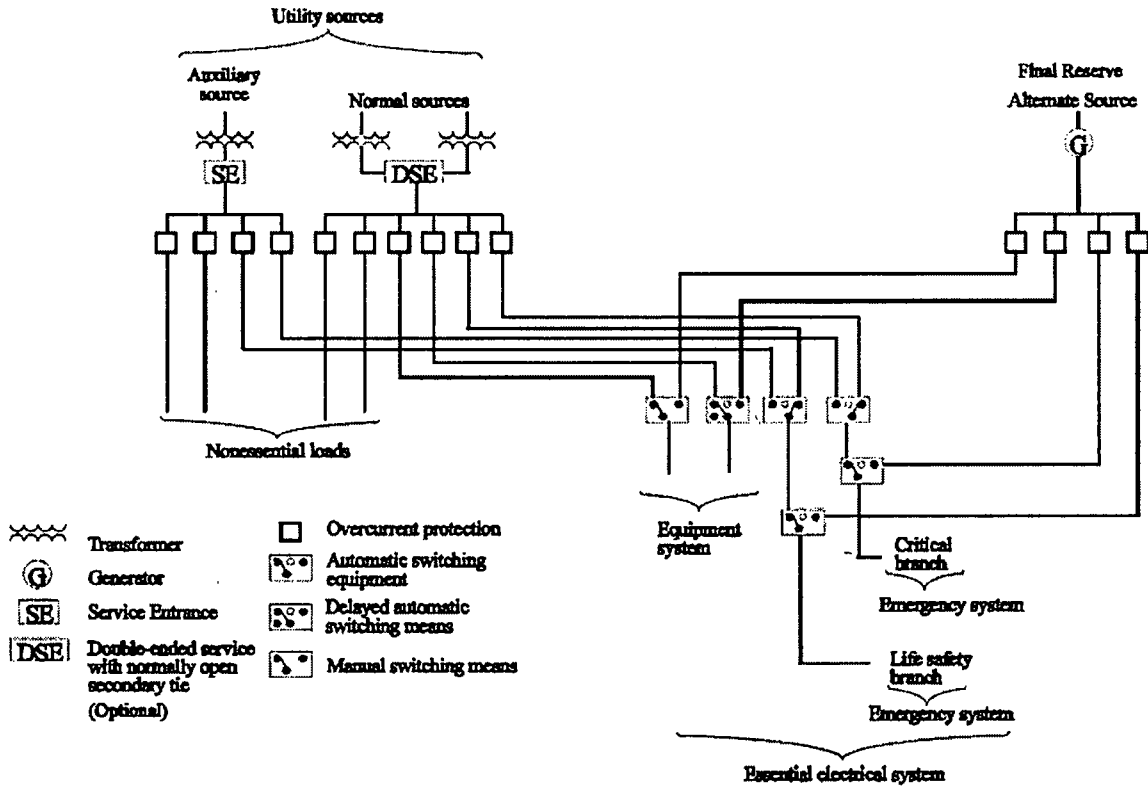

Insert Figure 517.29(B)(4)(b):

[Remainder of Page Intentionally Left Blank]

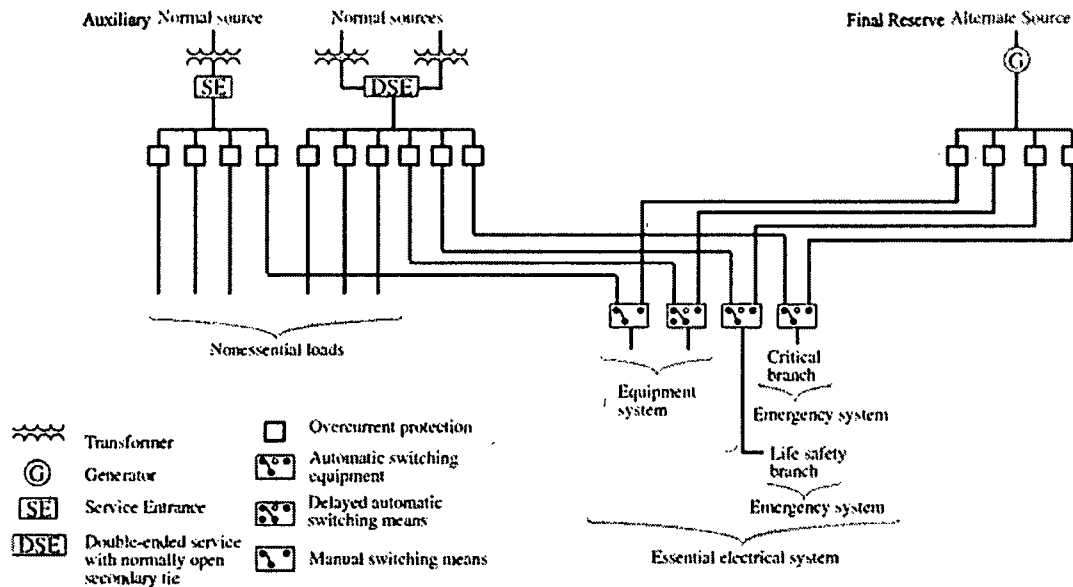

Revise section 517.30 to read:

“Sources of Power.

(A) Three Independent Sources of Power. Hospital electrical systems shall have a minimum of three independent sources of power: a normal source, an auxiliary source, and a final reserve source. Hospitals are required to have a System I Emergency System as defined in Article 700.

Essential electrical systems of hospitals providing obstetrical or surgical or critical care treatment shall be supplied by a minimum of two or more separate central station fed electrical services plus an on-site final reserve source, as per Figure 517. 29(B)(4)(a).

Exception: Hospitals not providing obstetrical, surgical or critical care treatment shall be served by a minimum of two independent sources; a normal and a final reserve source.

(B) Alternate Source of Power. The alternate source of power shall consist of an auxiliary or a final reserve source of power.

(C) Location of Essential Electrical System Components. Careful consideration shall be given to the location of the spaces housing the components of the essential electrical system to minimize interruptions caused by natural forces common to the area (e.g., storms, floods, earthquakes, or hazards created by adjoining structures or activities). Service rooms, generator rooms, and wire closets shall be for the exclusive use of electrical switchgear and distribution equipment. They shall not be used for other systems or equipment. All electrical equipment shall be installed in electrical rooms. They shall be void of air circulation ducts, piping systems for liquids, gases, or vapors. They shall contain no foreign equipment.

Branch circuit panelboards feeding critical and special care areas shall be located on the same floor as the loads they serve. These panelboards shall be easily accessible from the areas that they serve.

Exception: Air circulation ducts designed to provide supply air or exhaust exclusively for those service rooms or wire closets.

(D) Location of Transfer Switches and Distribution Equipment. Transfer switches and distribution equipment for the essential electrical systems shall not be in the service or generator rooms.

(E) Selective Coordination. Health care facilities overcurrent devices shall be selectively coordinated with all supply-side overcurrent protective devices.

Selective coordination shall be selected by a licensed professional engineer or other qualified persons engaged primarily in the design, installation, or maintenance of electrical systems. The selection shall be documented and made available to those authorized to design, install, inspect, maintain, and operate the system and be submitted to the authority having jurisdiction.”

Delete section 517.31 in its entirety.

Revise section 517.32 to read:

“Emergency System. Those functions of patient care depending on lighting or appliances that are connected to the emergency system shall be divided into two mandatory branches: the life safety branch and the critical branch, described in 517.33 and 517.34.

The branches of the emergency system shall be installed and connected to the alternate power source(s) so that all functions specified herein for the emergency system shall be automatically restored to operation within 10 seconds after interruption of the normal source.”

Revise section 517.33 to read:

“Life Safety Branch. No function other than those listed in (A) through (F) of this section shall be connected to the life safety branch. The life safety branch of the emergency system shall supply power for the following lighting, receptacles, and equipment.

(A) Illumination of Means of Egress. Illumination of means of egress, such as lighting required for corridors, passageways, stairways, and landings at exit doors, and all necessary ways of approach to exits.

(B) Exit Signs. Exit signs and exit directional signs.

(C) Fire Alarm Systems. Fire alarm systems.

(D) Elevators. Elevator cab lighting, control, communications, and signal systems.”

Revise section 517.34 to read:

“Critical Branch.

(A) Task Illumination and Selected Receptacles. The critical branch of the emergency system shall supply power for task illumination, fixed equipment, selected

receptacles, and special power circuits serving the following areas and functions related to patient care.

(1) Critical care areas that utilize anesthetizing gases task illumination, selected receptacles, and fixed equipment.

(2) The isolated power systems in special environments.

(3) Patient care areas task illumination and selected receptacles in the following:

- (a) Infant nurseries
- (b) Medication preparation areas
- (c) Pharmacy dispensing areas
- (d) Selected acute nursing areas
- (e) Psychiatric bed areas (omit receptacles)
- (f) Ward treatment rooms
- (g) Nurses' stations (unless adequately lighted by corridor luminaires).

(4) Additional specialized patient care task illumination and receptacles, where needed

(5) Nurse call systems

(6) Blood, bone, and tissue banks

(7) Telephone equipment room(s) and closet(s).

(8) Task illumination, selected receptacles, and selected power circuits for:

- (a) General care beds (at least one duplex receptacle per patient bedroom)
- (b) Angiographic labs
- (c) Cardiac catheterization labs
- (d) Coronary care units
- (e) Hemodialysis rooms or areas
- (f) Emergency room treatment areas (selected)
- (g) Human physiology labs
- (h) Intensive care units
- (i) Postoperative recovery rooms (selected).

Informational Note: Normal branch circuits are also required in these areas.

(9) Additional task illumination, receptacles, and selected power circuits needed for effective hospital operation. Single phase fractional horsepower exhaust fan motors that are interlocked with 3 phase motors on the equipment shall be permitted to be connected to the critical branch.

(B) Subdivision of the Critical Branch. It shall be permitted to subdivide the critical branch into two or more branches.

(C) Receptacle Identification. The receptacles supplied by the critical branch shall have a red body so as to be readily recognizable.

(D) Alarm and Alerting Systems. Alarms required for systems used for the piping of nonflammable medical gases.

(E) Systems for Patient Monitoring. Systems for monitoring patient condition or functions.

(F) Communications Systems. Hospital communications systems, where used for issuing instructions during emergency conditions.

(G) Generator Set Location. Task illumination battery charger for emergency battery powered lighting unit(s) and selected receptacles at the generator set location.

(H) Generator Set Accessories. Generator set accessories as required for generator performance. Loads dedicated to a specific generator, including the fuel transfer pump(s), ventilation fans, electrically operated louvers, controls, cooling system and other generator accessories essential for generator operation, shall be connected to the critical branch or to the output terminals of the generator with overcurrent protective devices.

(I) Automatic Doors. Electrically powered doors used for building egress.”

Revise section 517.35 to read:

“Equipment System Connection to Alternate Power Source. The equipment system shall be installed and connected to the alternate source, such that the equipment described in 517.35(A) is automatically restored to operation at appropriate time lag intervals following the energizing of the emergency system. Its arrangement shall also provide for the subsequent connection of equipment described in 517.35(B).

(A) Equipment for Delayed Automatic Connection. The following equipment shall be arranged for delayed automatic connection to the alternate power source:

(1) Central suction systems serving medical and surgical functions, including controls. Such suction systems shall be permitted on the critical branch.

(2) Sump pumps and other equipment required to operate for the safety of major apparatus, including associated control systems and alarms.

(3) Compressed air systems serving medical and surgical functions, including controls.

(4) Smoke control and stair pressurization systems.

(5) Kitchen hood supply and/or exhaust systems, if required to operate during a fire in or under the hood.

Exception: Sequential delayed automatic connection to the alternate power source to prevent overloading the generator shall be permitted where engineering studies indicate it is necessary.

(B) Equipment for Delayed Automatic or Manual Connection. The following equipment shall be arranged for either delayed automatic or manual connection to the

alternate power source:

(1) Heating equipment to provide heating for operating, delivery, labor, recovery, intensive care, coronary care, nurseries, infection/ isolation rooms, emergency treatment spaces, and general patient rooms.

(2) An elevator(s) selected to provide service to patient, surgical, obstetrical, and ground floors during interruption of normal power.

In instances where interruption of normal power would result in other elevators stopping between floors, throw over facilities shall be provided to allow the temporary operation of any elevator for the release of patients or other persons who may be confined between floors.

(3) Supply, return, and exhaust ventilating systems for surgical and obstetrical delivery suites, intensive care, coronary care, nurseries, infection/isolation rooms, emergency treatment spaces, and exhaust fans for laboratory fume hoods, nuclear medicine areas where radioactive material is used, ethylene oxide evacuation, and anesthesia evacuation.

(4) Hyperbaric facilities.

(5) Hypobaric facilities.

(6) Automatically operated doors.

(7) Minimal electrically heated autoclaving equipment shall be permitted to be arranged for either automatic or manual connection to the alternate source.

(8) Other selected equipment shall be permitted to be served by the equipment system.”

Revise section 517.40 to read:

“Essential Electrical Systems for Nursing Homes and Limited Care Facilities.

(A) Applicability. The requirements of Part III, 517.40(C) through 517.44, shall apply to nursing homes and limited care facilities.

Exception: Freestanding buildings used as nursing homes and limited care facilities, provided:

(a) Admitting and discharge policies are maintained that preclude the provision of care for any patient or resident who may need to be sustained by electrical life support equipment.

(b) No surgical treatment requiring general anesthesia is offered.

(c) An automatic battery operated system(s) or equipment is provided that shall be effective for at least 2 hours and is otherwise in accordance with Article 700 and that shall be capable of supplying lighting for exit lights, exit corridors, stairways, nursing stations, medical preparation areas, boiler rooms, and communication areas. This

system shall also supply power to operate all alarm systems.

(B) Inpatient Hospital Care Facilities. Nursing homes and limited care facilities that provide inpatient hospital care shall comply with the requirements of Part III, 517.29 through 517.35.

(C) Facilities Contiguous with Hospitals. Nursing homes and limited care facilities that are contiguous or located on the same site with a hospital shall be permitted to have their essential electrical systems supplied by that of the hospital.

Insert new figure 517.40:

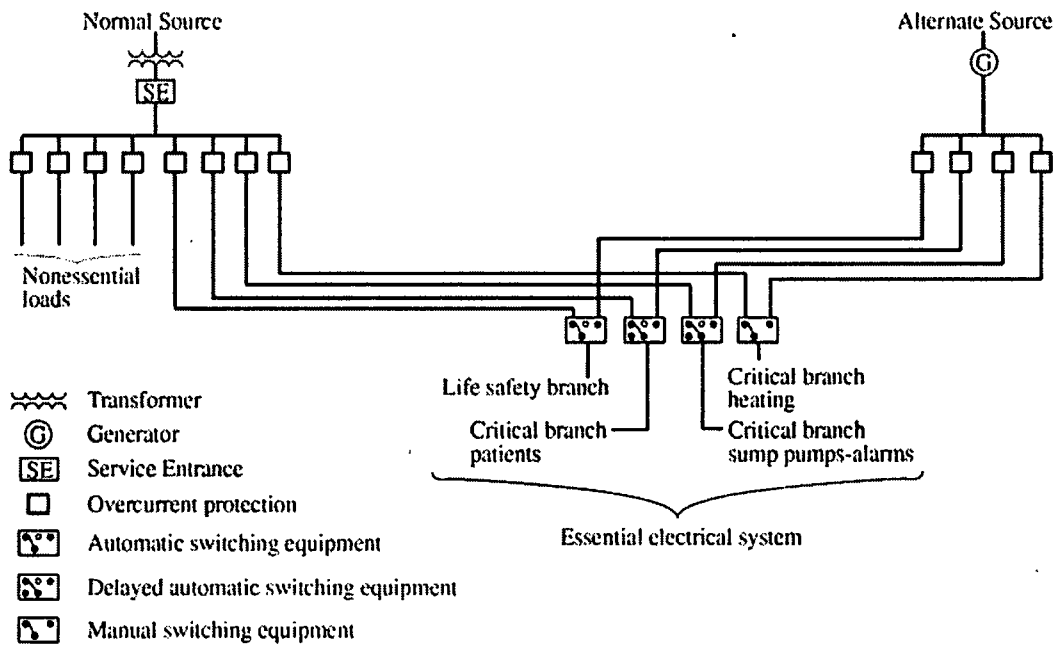

Revise section 517.41 to read:

“Sources of Power.

(A) Two Independent Sources of Power. Essential electrical systems shall have a minimum of two independent sources of power: a normal source generally supplying the entire electrical system, and one or more alternate sources for use when the normal source is interrupted.

(B) Alternate Source of Power. The alternate source of power shall be a generator(s) driven by some form of prime mover(s), and located on the premises.

Exception No. 1: Where the normal source consists of generating units on the premises, the alternate source shall be either another generator set, or an external utility service.

Exception No. 2: Nursing homes or limited care facilities meeting the requirements of 517.40(A), Exception, shall be permitted to use a battery system or self contained battery integral with the equipment.

(C) Location of Essential Electrical System Components. Careful consideration shall be given to the location of the spaces housing the components of the essential electrical system to minimize interruptions caused by natural forces common to the area (e.g., storms, floods, earthquakes, or hazards created by adjoining structures or activities). Consideration shall also be given to the possible interruption of normal electrical services resulting from similar causes as well as possible disruption of normal electrical service due to internal wiring and equipment failures.

Informational Note: Facilities whose normal source of power is supplied by two or more separate central station fed services experience greater than normal electrical service reliability than those with only a single feed. Such a dual source of normal power consists of two or more electrical services fed from separate generator sets or a utility distribution network having multiple power input sources and arranged to provide mechanical and electrical separation so that a fault between the facility and the generating sources will not likely cause an interruption of more than one of the facility service feeders.”

Revise section 517.42 to read:

“Essential Electrical Systems.

(A) General. Essential electrical systems for nursing homes and limited care facilities shall be comprised of two separate branches capable of supplying a limited amount of lighting and power service, which is considered essential for the protection of life safety and effective operation of the institution during the time normal electrical service is interrupted for any reason. These two separate branches shall be the life safety branch and the critical branch.

(B) Transfer Switches. The number of transfer switches to be used shall be based upon reliability, design, and load considerations. Each branch of the essential electrical system shall be served by one or more transfer switches as shown in Figure 517.40.

(C) Capacity of System. The essential electrical system shall have adequate capacity to meet the demand for the operation of all functions and equipment to be served by each branch at one time.

(D) Separation from Other Circuits. The life safety branch shall be kept entirely independent of all other wiring and equipment and shall not enter the same raceways, boxes, or cabinets with other wiring except in transfer switches.”

Revise section 517.43 to read:

“Automatic Connection to Life Safety Branch. The life safety branch shall be so installed and connected to the alternate source of power that all functions specified herein shall be automatically restored to operation within 10 seconds after the interruption of the normal source. No function other than those listed in 517.43(A) through (E) shall be connected to the life safety branch. The life safety branch shall supply power for the following lighting and equipment:

Informational Note: The life safety branch is called the emergency system in Standard for Health Care Facilities, NFPA 99.

- (A) **Illumination of Means of Egress.** Illumination of means of egress as is necessary for corridors, passageways, stairways, landings, and exit doors and all ways of approach to exits.
- (B) **Exit Signs.** Exit signs and exit directional signs.
- (C) **Required Fire Alarm Systems.** Required fire alarm systems.
- (D) **Dining and Recreation Areas.** Sufficient lighting in dining and recreation areas to provide illumination to exit ways.
- (E) **Elevators.** Elevator cab lighting, control, communications, and signal systems

Revise section 517.44 to read:

“Connection to Critical Branch. The critical branch shall be so installed and connected to the alternate power source that the equipment listed in 517.44(A) shall be automatically restored to operation at appropriate time lag intervals following the restoration of the life safety branch to operation. Its arrangement shall also provide for the additional connection of equipment listed in 517.44(B) by either delayed automatic or manual operation.

(A) Delayed Automatic Connection. The following equipment shall be connected to the critical branch and shall be arranged for delayed automatic connection to the alternate power source:

(1) Patient care areas - task illumination and selected receptacles in:

- a. Medication preparation areas.
- b. Pharmacy dispensing areas.
- c. Nurses' stations (unless adequately lighted by corridor luminaires).

(2) Sump pumps and other equipment required to operate for the safety of major apparatus and associated control systems and alarms.

(3) Alarms and alerting systems including alarms required for systems used for the piping of nonflammable medical gases.

(4) Task illumination and selected receptacles in the generator set location.

(5) Communications systems, where used for issuing instructions during emergency conditions.

(6) Smoke control and stair pressurization systems.

(7) Kitchen hood supply and/or exhaust systems, if required to operate during a fire in or under the hood.

(B) Delayed Automatic or Manual Connection. The following equipment shall be connected to the critical branch and shall be arranged for either delayed automatic or manual connection to the alternate power source:

(1) Heating Equipment. Heating equipment to provide heating for patient rooms.

(2) Elevator Service. In instances where disruption of power would result in elevators stopping between floors, throw over facilities shall be provided to allow the temporary operation of any elevator for the release of passengers. For elevator cab lighting, control, and signal system requirements, see 517.42(E).

(3) Additional Loads. Additional illumination, receptacles, and equipment shall be permitted to be connected only to the critical branch.”

Revise section 517.45 to read:

“Essential Electrical Systems for Ambulatory Health Care Occupancies.

(A) Applicability. The requirements of this section shall apply to ambulatory health care occupancies, other than those covered by Section 517.29 or Section 517.40.

(B) Connections. The essential electrical system shall supply power for:

(1) Task illumination that is related to the safety of life and that is necessary for the safe cessation of procedures in progress.

(2) All anesthesia and resuscitative equipment used in areas where inhalation anesthetics are administered to patients, including alarm and alerting devices.

(3) All electrical life support equipment in areas where procedures are performed that require such equipment for the support of the patient's life.

(C) Alternate Source of Power.

(1) Power Source. The alternate source of power for the system shall be specifically designed for this purpose and shall be either a generator, battery system, or self-contained battery integral with the equipment.

Exception: If critical care (category 1) areas are present in the facility, the essential electrical system shall be as required in 517.29 through 517.35.

(2) System Capacity. The alternate source of power shall be separate and independent of the normal source and shall have a capacity to sustain its connected loads for a minimum of 2 hours after loss of the normal source.

(3) System Operation. The system shall be arranged so that, in the event of a failure of the normal power source, the alternate source of power shall be automatically connected to the load within 10 seconds.”

Insert Figure 517.45:

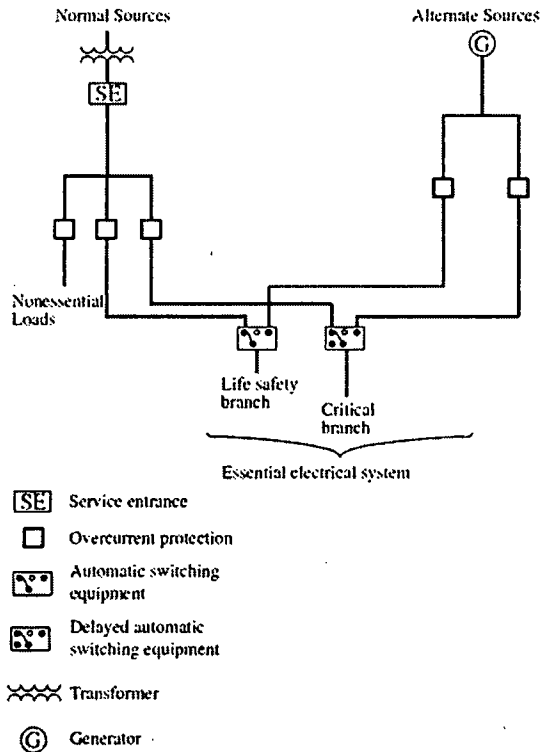

Insert new section 517.50 to read:

“Essential Electrical Systems for Health Care Facilities Not Covered in 517.29, 517.40, and 517.45.

(A) Applicability. The requirements of this section shall apply to health care facilities other than those covered by Sections 517.29, 517.40 or 517.45.

(B) Connections. The essential electrical system shall supply power for:

- (1) Task illumination that is related to the safety of life and that is necessary for the safe cessation of procedures in progress.
- (2) All anesthesia and resuscitative equipment used in areas where inhalation anesthetics are administered to patients, including alarm and alerting devices.

(C) Alternate Source of Power.

(1) Power Source. The alternate source of power for the system shall be specifically designed for this purpose and shall be either a generator, battery system, or self-contained battery integral with the equipment.

Exception: If electrical life support equipment is required, the essential electrical system shall be as required in 517.29 through 517.35.

(2) System Capacity. The alternate source of power shall be separate and independent of the normal source and shall have a capacity to sustain its connected loads for a

minimum of 2 hours after loss of the normal source.

(3) System Operation. The system shall be arranged so that, in the event of a failure of the normal power source, the alternate source of power shall be automatically connected to the load within 10 seconds.”

Revise subsection 517.61(B)(1) to read:

“ **Wiring Methods.** Wiring above a hazardous (classified) location referred to in 517.60 shall be installed in rigid metal conduit, electrical metallic tubing, intermediate metal conduit, or Type MI cable.”

Revise subsection 517.61(C)(1) to read:

“**Wiring Methods.** Wiring serving other-than-hazardous (classified) locations, as defined in 517.60, shall be installed in a metal raceway system. The metal raceway system shall qualify as an equipment grounding conductor in accordance with 250.118. Type MI cable shall have an outer metal armor, sheath, or sheath assembly that is identified as an acceptable equipment grounding conductor.”

Revise subsection 517.61(C)(4) to read:

“**Anesthetizing Location Power Circuits.** Each power within, or partially within an anesthetizing location referred in 517.60 shall be isolated from any distribution system by the use of an isolated power system.”

14E-5-518 Assembly Occupancies

The provisions of Article 518 of NFPA 70 are adopted by reference with the following modifications:

Revise subsection 518.4(A) to read:

“**General.** The fixed wiring methods shall be metal raceways, flexible metal raceways, or Type MI cable.

Exception: Fixed wiring methods shall be as provided in Article 640 for audio signal processing, amplification, and reproduction equipment, in Article 800 for communications circuits, in Article 725 for Class 2 and Class 3 remote-control and signaling circuits, and in Article 760 for fire alarm circuits.”

Delete subsections 518.4(B) and (C) in their entirety.

14E-5-520 Theaters, Audience Areas of Motion Picture and Television Studios, and Similar Locations

The provisions of Article 520 of NFPA 70 are adopted by reference with the following modifications:

Revise subsection 520.5(A) to read:

"General. The fixed wiring methods shall be metal raceways or Type MI cable.

Exception: Fixed wiring methods shall be as provided in Article 640 for audio signal processing, amplification, and reproduction equipment, in Article 800 for communications circuits, in Article 725 for Class 2 and Class 3 remote-control and signaling circuits, and in Article 760 for fire alarm circuits."

Delete subsection 520.5(C) in its entirety.

14E-5-522 Control Systems for Permanent Amusement Attractions

The provisions of Article 522 of NFPA 70 are adopted by reference without modification.

14E-5-525 Carnivals, Circuses, Fairs, and Similar Events

The provisions of Article 525 of NFPA 70 are adopted by reference without modification.

14E-5-530 Motion Picture and Television Studios and Similar Locations

The provisions of Article 530 of NFPA 70 are adopted by reference with the following modification:

Revise section 530.11 to read:

"Permanent Wiring. The permanent wiring shall be Type MI cable, or in approved raceways.

Exception: Communications circuits; audio signal processing, amplification, and reproduction circuits; Class 1, Class 2, and Class 3 remote-control or signaling circuits and power-limited fire alarm circuits shall be permitted to be wired in accordance with Articles 640, 725, 760, and 800."

14E-5-540 Motion Picture Projection Rooms

The provisions of Article 540 of NFPA 70 are adopted by reference without modification.

14E-5-545 Manufactured Buildings

The provisions of Article 545 of NFPA 70 are not adopted. Article 545 shall read in its entirety:

"545.1 Scope. This article covers the requirements for a manufactured building and building components as herein defined.

545.2 Definitions.

Building Component. Any subsystem, subassembly, or other system designed for use in or integral with or as part of a structure, which can include structural, electrical, mechanical, plumbing, and fire protection systems, and other systems affecting health and safety.

Closed Construction. Any building, building component, assembly, or system manufactured in such a manner that all concealed parts of processes of manufacture

cannot be inspected after installation at the building site without disassembly, damage, or destruction.

Manufactured Building. Any building that is of closed construction and is made or assembled in manufacturing facilities on or off the building site for installation, or for assembly and installation on the building site, other than manufactured homes, mobile homes, park trailers, or recreational vehicles.

545.3 Other Articles. Manufactured buildings shall comply with all applicable articles of this *Code*.”

14E-5-547 Agricultural Buildings

The provisions of Article 547 of NFPA 70 are adopted by reference with the following modification:

Revise subsection 547.5(A) to read:

“**Wiring Methods.** Raceways suitable for the location, with approved termination fittings, shall be the wiring method employed. The wiring methods of Article 502, Part II, shall be permitted for areas described in 547.1(A).”

14E-5-550 Mobile Homes, Manufactured Homes, and Mobile Home Parks

The provisions of Article 550 of NFPA 70 are adopted by reference with the following modifications:

Revise section 550.1 to read:

“**Scope.** To the extent such installation are subject to regulation by the City of Chicago, the provisions of this article cover the electrical conductors and equipment installed within or on mobile homes, the conductors that connect mobile to a supply of electricity, and the installation of electrical wiring, luminaires, equipment, and appurtenances related to electrical installations within a mobile home park up to the mobile home service-entrance conductors or, if none, the mobile home service equipment.

Manufactured homes shall comply with Chapters 1 through 4 of this Title with regard to materials, electrical installation and electrical construction methods.

Informational Note: For additional information on manufactured housing see NFPA 501-2013, Standard on Manufactured Housing, and Part 3280, Manufactured Home Construction and Safety Standards, of the Federal Department of Housing and Urban Development.”

Revise section 550.10 to read:

“**Power Supply.**

(A) Feeder. The power supply to the mobile home shall be a feeder assembly consisting of a permanently installed feeder of at least 60 amperes.

(B) Point of Entrance. The point of entrance of the feeder assembly to the mobile home shall be in the exterior wall, floor, or roof.

(C) Mast Weatherhead or Raceway. The permanent feeder shall be installed by one of the following means:

- (1) One mast weatherhead installation, installed in accordance with Article 230, containing four continuous, insulated, color-coded feeder conductors, one of which shall be an equipment grounding conductor
- (2) A metal raceway from the disconnecting means in the mobile home to the underside of the mobile home, with provisions for the attachment to a suitable junction box or fitting to the raceway on the underside of the mobile home."

Revise Section 550.15 to read:

"Wiring Methods and Materials. Except as specifically limited in this section, the wiring methods and materials included in this Title shall be used in mobile homes and manufactured homes.

(A) Metal Faceplates. Where metal faceplates are used, they shall be effectively grounded.

(B) Installation Requirements. If a range, clothes dryer, or similar appliance is connected by metal- covered cable or flexible metal conduit, a length of not less than 900 mm (3 ft) of free cable or conduit shall be provided to permit moving the appliance. The cable or flexible metal conduit shall be secured to the wall. Type NM or Type SE cable shall not be used to connect a range or dryer.

(C) Raceways. Where rigid metal conduit or intermediate metal conduit is terminated at an enclosure with a locknut and bushing connection, two locknuts shall be provided, one inside and one outside of the enclosure. Surface raceway shall be permitted. All cut ends of conduit shall be reamed or otherwise finished to remove rough edges.

(D) Switches. Switches shall be rated as follows:

- (1) For lighting circuits, switches shall be rated not less than 15 amperes, 120 to 125 volts, and in no case less than the connected load.
- (2) For motors or other loads, switches shall have ampere or horsepower ratings, or both, adequate for loads controlled. (An ac general-use snap switch shall be permitted to control a motor 2 hp or less with full-load current not over 80 percent of the switch ampere rating.)

(E) Under-Chassis Wiring (Exposed to Weather).

- (1) Where outdoor or under-chassis line- voltage (120 volts, nominal, or higher) wiring is exposed to moisture or physical damage, it shall be protected by rigid metal conduit or intermediate metal conduit. The conductors shall be suitable for wet locations.

Exception: Electrical metallic tubing or rigid nonmetallic conduit shall be permitted where

closely routed against frames and equipment enclosures

(2) The conductors shall be Type TW, or equivalent.

(F) Boxes, Fittings, and Cabinets. Boxes, fittings, and cabinets shall be securely fastened in place and shall be supported from a structural member of the home, either directly or by using a substantial brace.

(G) Appliance Terminal Connections. Appliances having branch-circuit terminal connections that operate at temperatures higher than 60°C (140°F) shall have circuit conductors as described in (1) or (2) of this subsection.

(1) Branch-circuit conductors having an insulation suitable for the temperature encountered shall be permitted to be run directly to the appliance.

(2) Conductors having an insulation suitable for the temperature encountered shall be run from the appliance terminal connection to a readily accessible outlet box placed at least 300 mm (1 ft) from the appliance. These conductors shall be in a suitable raceway that shall extend for at least 1.2 m (4 ft).

(H) Component Interconnections. Fittings and connectors that are intended to be concealed at the time of assembly shall be listed and identified for the interconnection of building components. Such fittings and connectors shall be equal to the wiring method employed in insulation, temperature rise, and fault-current withstanding and shall be capable of enduring the vibration and shock occurring in mobile home transportation.”

14E-5-551 Recreational Vehicles and Recreational Vehicle Parks

The provisions of Article 551 of NFPA 70 are adopted by reference without modification.

14E-5-552 Park Trailers

The provisions of Article 552 of NFPA 70 are adopted by reference with the following modification:

Revise section 552.48 to read:

“Wiring Methods.

(A) Wiring Systems. Cables and raceways shall be installed in accordance with the permissible Chapter 3 wiring methods, except as otherwise specified in this article. An equipment grounding means shall be provided in accordance with 250.118.

(B) Conduit and Tubing. Where rigid metal conduit or intermediate metal conduit is terminated at an enclosure with a locknut and bushing connection, two locknuts shall be provided, one inside and one outside of the enclosure. All cut ends of conduit and tubing shall be reamed or otherwise finished to remove rough edges.

(C) Boxes. In walls and ceilings constructed of wood or other combustible material, boxes and fittings shall be flush with the finished surface or project therefrom.

(D) Mounting. Wall and ceiling boxes shall be mounted in accordance with Article 314.

Exception No. 1: Snap-in-type boxes or boxes provided with special wall or ceiling brackets that securely fasten boxes in walls or ceilings shall be permitted.

Exception No. 2: A wooden plate providing a 1½ in. minimum width backing around the box and of a thickness of ½ in. or greater (actual) attached directly to the wall panel shall be considered as approved means for mounting outlet boxes.

(E) Raceway and Cable Continuity. Raceways and cable, shall be continuous between outlet boxes and other enclosures.

(F) Protected. Electrical metallic tubing shall be permitted to pass through the centers of the wide side of 2x4 wood studs. However, they shall be protected where they pass through 2x2 wood studs or at other wood studs or frames where the cable or tubing would be less than 31.8 mm (1¼ in.) from the inside or outside surface. Steel plates on each side of the cable or tubing or a steel tube, with not less than 0.053 in. wall thickness, shall be installed to protect the cable or tubing.

(G) Cable Supports. Where connected with cable connectors or clamps, cables shall be secured and supported within 305 mm (12 in.) of outlet boxes, panelboards, and splice boxes on appliances. Supports and securing shall be provided at intervals not exceeding 1.37 m (4.5 ft) at other places.

(H) Physical Damage. Where subject to physical damage, exposed nonmetallic cable shall be installed in metal raceways.

(I) Receptacle Faceplates. Metal faceplates shall comply with 406.5(A). Nonmetallic faceplates shall comply with 406.5(C).

(J) Metal Faceplates Grounded. Where metal faceplates are used, they shall be grounded.

(K) Moisture or Physical Damage. Where outdoor or under-chassis wiring is 120 volts, nominal, or over and is exposed to moisture or physical damage, the wiring shall be protected by rigid metal conduit, by intermediate metal conduit, by electrical metallic tubing, or by Type MI cable that is closely routed against frames and equipment enclosures or other raceway or cable identified for the application.

(L) Component Interconnections. Fittings and connectors that are intended to be concealed at the time of assembly shall be listed and identified for the interconnection of building components. Such fittings and connectors shall be equal to the wiring method employed in insulation, temperature rise, and fault-current withstanding, and shall be capable of enduring the vibration and shock occurring in park trailers.

(M) Method of Connecting Expandable Units. The method of connecting expandable units to the main body of the park trailer shall comply with the following as applicable:

(1) Cord-and-Plug Connected. Cord-and-plug connections shall comply with 552.48(M)(1)(a) through (M)(1)(d).

(a) The portion of a branch circuit that is installed in an expandable unit shall be permitted to be connected to the portion of the branch circuit in the main body of the vehicle by means of a flexible cord or attachment plug and cord listed for hard usage. The cord and its connections shall comply with all provisions of Article 400 and shall be considered as a permitted use under 400.10.

(b) Where the receptacle provided for connection of the cord to the main circuit is located on the outside of the park trailer, it shall be protected with a ground-fault circuit interrupter for personnel and be listed for wet locations. A cord located on the outside of a park trailer shall be identified for outdoor use.

(c) Unless removable or stored within the park trailer interior, the cord assembly shall have permanent provisions for protection against corrosion and mechanical damage while the park trailer is in transit.

(d) The attachment plug and cord shall be installed so as not to permit exposed live attachment plug pins.

(2) Direct Wires Connected. That portion of a branch circuit that is installed in an expandable unit shall be permitted to be connected to the portion of the branch circuit in the main body of the park trailer by means of flexible cord installed in accordance with 552.48(M)(2)(a) through (M)(2)(f) or other approved wiring method.

(a) The flexible cord shall be listed for hard usage and for use in wet locations.

(b) The flexible cord shall be permitted to be exposed on the underside of the vehicle.

(c) The flexible cord shall be permitted to pass through the interior of a wall or floor assembly or both a maximum concealed length of 610 mm (24 in.) before terminating at an outlet or junction box.

(d) Where concealed, the flexible cord shall be installed in nonflexible conduit or tubing that is continuous from the outlet or junction box inside the park trailer to a weatherproof outlet box, junction box, or strain relief fitting listed for use in wet locations that is located on the underside of the park trailer. The outer jacket of flexible cord shall be continuous into the outlet or junction box.

(e) Where the flexible cord passes through the floor to an exposed area inside of the park trailer, it shall be protected by means of conduit and bushings or equivalent.

(f) Where subject to physical damage, the flexible cord shall be protected with RMC, IMC, Schedule 80 PVC, reinforced thermosetting resin conduit (RTRC) listed for exposure to physical damage, or other approved means and shall extend at least 6 in. above the floor. A means shall be provided to secure the flexible cord where it enters the park trailer.

(N) Prewiring for Air-Conditioning Installation. Prewiring installed for the purpose of facilitating future air-conditioning installation shall comply with the applicable portions of this article and the following:

(1) An overcurrent protective device with a rating compatible with the circuit conductors

shall be installed in the distribution panelboard and wiring connections completed.

(2) The load end of the circuit shall terminate in a junction box with a blank cover or other listed enclosure. Where a junction box with a blank cover is used, the free ends of the conductors shall be adequately capped or taped.

(3) A safety label with the signal word WARNING in minimum ¼ in. high letters and body text in minimum ⅛ in. high letters on a contrasting background. The safety label shall be affixed on or adjacent to the junction box and shall read:

AIR-CONDITIONING CIRCUIT. THIS CONNECTION IS FOR AIR CONDITIONERS RATED 110–125-VOLT AC, 60 HZ, _____ AMPERES MAXIMUM. DO NOT EXCEED CIRCUIT RATING. EXCEEDING THE CIRCUIT RATING MAY CAUSE A FIRE AND RESULT IN DEATH OR SERIOUS INJURY.

An ampere rating, not to exceed 80 percent of the circuit rating, shall be legibly marked in the blank space.

(4) The circuit shall serve no other purpose.

(O) Prewiring for Other Circuits. Prewiring installed for the purpose of installing other appliances or devices shall comply with the applicable portions of this article and the following:

(1) An overcurrent protection device with a rating compatible with the circuit conductors shall be installed in the panelboard with wiring connections completed.

(2) The load end of the circuit shall terminate in a junction box with a blank cover or a device listed for the purpose. Where a junction box with blank cover is used, the free ends of the conductors shall be adequately capped or taped.

(3) A safety label with the signal word WARNING in minimum ¼ in. high letters and body text in minimum ⅛ in. high letters on a contrasting background. The safety label shall be affixed to the junction box or device listed for the purpose and shall read:

THIS CONNECTION IS FOR _____ RATED _____ VOLT AC, 60 HZ, _____ AMPERES MAXIMUM. DO NOT EXCEED THE CIRCUIT RATING. EXCEEDING THE CIRCUIT RATING MAY CAUSE A FIRE AND RESULT IN DEATH OR SERIOUS INJURY.

The intended appliance type shall be legibly marked in the first blank space. An ampere rating not to exceed 80 percent of the circuit rating shall be legibly marked in the second blank space.”

14E-5-553 Floating Buildings

The provisions of Article 553 of NFPA 70 are adopted by reference with the following modification:

Revise subsection 553.7(B) to read:

“Wiring Methods. Liquidtight flexible metal conduit with approved fittings shall be permitted for feeders and where flexible connections are required for services. Extra-hard usage portable power cable listed for both wet locations and sunlight resistance shall be permitted for a feeder to a floating building where flexibility is required. Other raceways suitable for the location shall be permitted to be installed where flexibility is not required.”

14E-5-555 Marinas and Boatyards

The provisions of Article 555 of NFPA 70 are adopted by reference without modification.

14E-5-560 Residential Occupancies

The following language shall be inserted as a new Article 560:

Part I. General

560.1 Scope. The special provisions of this section shall apply to the electrical installations in residential occupancies. In some cases they are repetitious and in some cases they are variations of general requirements appearing elsewhere in this *Code*.

560.2 Wiring Methods.

(A) Low-Voltage Class 2 Wiring. Low-voltage wiring for control or signaling, telephone systems, antenna systems, or communication systems which is enclosed in building partitions, walls or in any way made inaccessible by building construction need not be enclosed in a raceway except at locations where such wiring may be subject to mechanical injury.

Informational Note: Raceways when used will protect the conductors during construction and provide ready means for replacement of conductors after the building is completed. These raceways need not terminate in a box or fitting as long as normal precautions are taken to protect the conductors against injury.

(B) Other than Low-Voltage Class 2 Wiring. All wiring other than low-voltage class 2 wiring shall comply with the applicable provisions of Chapter 3.

560.3 Smoke Detectors and Carbon Monoxide Detectors.

(A) Smoke Detectors. Smoke detectors and carbon monoxide detectors shall be provided and installed in accordance with Chapter 13-64.

Part II. Branch Circuits

560.4 General. Part II specifies the branch circuit, receptacle outlets, and lighting outlet requirements. Voltages for branch-circuit, receptacle outlets and lighting outlets shall be limited to those specified in 210.6.

560.5 Branch Circuit Requirements. Branch circuits for lighting and for appliances, including motor-operated appliances, shall be provided to supply the loads computed in accordance with 220.10. These circuits shall comply with the requirements of 210.23. In addition, branch circuits shall be provided for specific loads not covered by 220.10 where required elsewhere in this *Code* and for dwelling unit loads as specified in 560.5(A) through (F).

(A) Number of Branch Circuits. The minimum number of branch circuits shall be determined from the total computed load and the size or rating of the circuits used. In all installations, the number of circuits shall be sufficient to supply the load served. In no case shall the load on any circuit exceed the maximum specified by 220.18.

(B) Small Appliance Branch Circuits. In addition to the number of branch circuits required by other parts of this section, two or more 20-ampere small-appliance branch circuits shall be provided for all receptacle outlets specified by 560.6(B).

(C) Laundry Branch Circuits. In addition to the number of branch circuits required by other parts of this section, at least one additional 20-ampere branch circuit shall be provided to supply the laundry receptacle outlet(s) required by 560.6(F). This circuit(s) shall have no other outlets.

(D) Bathroom Branch Circuit. In addition to the number of branch circuits required by other parts of this section, at least one 20-ampere branch circuit shall be provided to supply the bathroom receptacle outlet(s). This circuit(s) shall have no other outlets.

(E) Garage Branch Circuits. In addition to the number of branch circuits required by other parts of this section, at least one 120-volt, 20-ampere branch circuit shall be installed to supply receptacle outlets in garages. This circuit shall have no other outlets.

Exception: This circuit shall be permitted to supply readily accessible outdoor receptacle outlets

Informational Note: See 422.12 for central heating equipment branch circuit requirements.

(F) Guest Rooms. Branch circuits shall be installed in accordance with 210.60.

560.6 Receptacle Outlet Requirements. This section provides requirements for 125-volt, 15- and 20-ampere receptacle outlets. The receptacles required by this section shall be in addition to any receptacle that is:

- (1) Part of a luminaire or appliance, or
- (2) Controlled by a wall switch in accordance with 210.70(A)(1), Exception No. 1, or
- (3) Located within cabinets or cupboards, or
- (4) Located more than 5½ ft. above the floor

Permanently installed electric baseboard heaters equipped with factory-installed receptacle outlets or outlets provided as a separate assembly by the manufacturer shall

be permitted as the required outlet or outlets for the wall space utilized by such permanently installed heaters. Such receptacle outlets shall not be connected to the heater circuits.

(A) General Provisions. In every kitchen, family room, dining room, living room, parlor, library, den, sunroom, bedroom, recreation room, or similar room or area of dwelling units, receptacle outlets shall be installed in accordance with the general provisions specified in 560.6(A)(1) through (A)(4).

(1) Spacing. Receptacles shall be installed such that no point measured horizontally along the floor line of any wall space is more than 1.83 m (6 ft) from a receptacle outlet.

(2) Wall Space. As used in this section, a wall space shall include the following:

(1) Any space 2 ft. or more in width (including space measured around corners) and unbroken along the floor line by doorways and similar openings, fireplaces, and fixed cabinets

(2) The space occupied by fixed panels in exterior walls, excluding sliding panels

(3) The space afforded by fixed room dividers, such as freestanding bar-type counters or railings

(3) Floor Receptacles. Receptacle outlets in floors shall not be counted as part of the required number of receptacle outlets unless located within 18 in. of the wall.

(4) Countertop Receptacles. Receptacles installed for countertop surfaces as specified in 560.6(C) shall not be considered as the receptacles required by 560.6(A).

(B) Small Appliances.

(1) Receptacle Outlets Served. In the kitchen, pantry, breakfast room, dining room, or similar area of a dwelling unit, the two or more 20-ampere small-appliance branch circuits required by 560.5(C)(1) shall serve all wall and floor receptacle outlets covered by 560.6(A), all countertop outlets covered by 560.6(C), and receptacle outlets for refrigeration equipment.

Exception No. 1: In addition to the required receptacles specified by 560.6, switched receptacles supplied from a general-purpose branch circuit as defined in 560.7(A)(1), Exception No. 1, shall be permitted.

Exception No. 2: The receptacle outlet for refrigeration equipment shall be permitted to be supplied from an individual branch circuit rated 15 amperes or greater.

(2) No Other Outlets. The two or more small-appliance branch circuits specified in 560.6(B)(1) shall have no other outlets.

Exception No. 1: A receptacle installed solely for the electrical supply to and support of an electric clock in any of the rooms specified in 560.6(B)(1).

Exception No. 2: Receptacles installed to provide power for supplemental equipment

and lighting on gas-fired ranges, ovens, or counter-mounted cooking units.

(3) Kitchen Receptacle Requirements. Receptacles installed in a kitchen to serve countertop surfaces shall be supplied by not fewer than two small-appliance branch circuits, either or both of which shall also be permitted to supply receptacle outlets in the same kitchen and in other rooms specified in 560.6(B)(1). Additional small-appliance branch circuits shall be permitted to supply receptacle outlets in the kitchen and other rooms specified in 560.6(B)(1). No small-appliance branch circuit shall serve more than one kitchen.

(C) Countertops. In kitchens, pantries, breakfast rooms, dining rooms, and similar areas of dwelling units, receptacle outlets for countertop spaces shall be installed in accordance with 560.6(C)(1) through (C)(5).

(1) Wall Countertop Spaces. A receptacle outlet shall be installed at each wall countertop space that is 12 in. or wider. Receptacle outlets shall be installed so that no point along the wall line is more than 24 in. measured horizontally from a receptacle outlet in that space.

Exception: Receptacle outlets shall not be required on a wall directly behind a range, counter-mounted cooking unit, or sink in the installation described in Figure 560.6(C)(1).

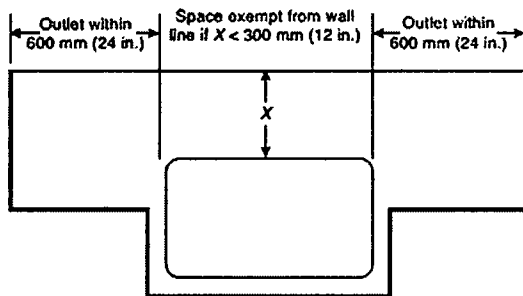

Range, counter-mounted cooking unit extending from face of counter

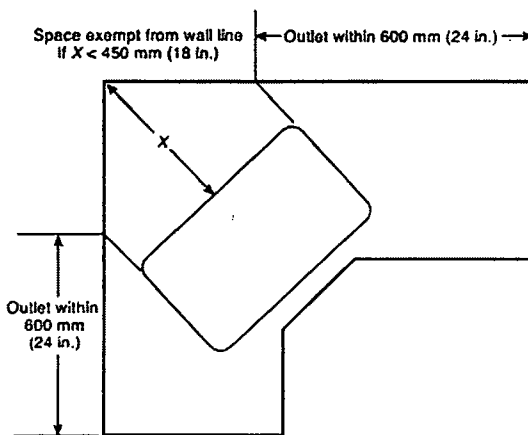

Range, counter-mounted cooking unit mounted in corner

Figure 560.6(c)(1) Determination of Area Behind a Range or Counter-Mounted Cooking Unit or Sink

(2) Island Countertop Spaces. At least one receptacle shall be installed at each island countertop space with a long dimension of 24 in. or greater and a short dimension of 12 in. or greater.

(3) Peninsular Countertop Spaces. At least one receptacle outlet shall be installed at each peninsular countertop space with a long dimension of 24 in. or greater and a short dimension of 12 in. or greater. A peninsular countertop is measured from the connecting edge.

(4) Separate Spaces. Countertop spaces separated by rangetops, refrigerators, or sinks shall be considered as separate countertop spaces in applying the requirements of 560.6(C)(1). If a range, counter-mounted cooking unit, or sink is installed in an island or peninsular countertop and the depth of the countertop behind the range, counter-mounted cooking unit, or sink is less than 12 in., the range, counter-mounted cooking unit, or sink shall be considered to divide the countertop space into two separate countertop spaces. Each separate countertop space shall comply with the applicable requirements in 560.6(C)

(5) Receptacle Outlet Location. Receptacle outlets shall be located on or above, but not more than 20 in. above, the countertop. Receptacle outlet assemblies listed for the application shall be permitted to be installed in countertops. Receptacle outlets rendered not readily accessible by appliances fastened in place, appliance garages, sinks, or rangetops as covered in 560.6(C)(1), Exception, or appliances occupying dedicated space shall not be considered as these required outlets.

Informational Note: See 406.5(E) and 406.5(G) for requirements for installation of receptacles in countertops and 406.5(F) and 406.5(G) for requirements for installations of receptacles in work surfaces.

Exception to (5): To comply with the conditions specified in (1) or (2), receptacle outlets shall be permitted to be mounted not more than 12 in. below the countertop.

Receptacles mounted below a countertop in accordance with this exception shall not be located where the countertop extends more than 6 in. beyond its support base.

(1) Construction for the physically impaired

(2) On island and peninsular countertops where the countertop is flat across its entire surface (no backsplashes, dividers, etc.) and there are no means to mount a receptacle within 20 in. above the countertop, such as an overhead cabinet

(D) Bathrooms. At least one receptacle outlet shall be installed in bathrooms within 3 ft. of the outside edge of each basin. The receptacle outlet shall be located on a wall or partition that is adjacent to the basin or basin countertop, located on the countertop, or installed on the side or face of the basin cabinet. In no case shall the receptacle be located more than 12 in. below the top of the basin or basin countertop. Receptacle outlet assemblies listed for use in countertops shall be permitted to be installed in the countertop

Informational Note: See 406.5(E) 406.5(G) for requirements for installation of receptacles in countertops.

(E) Outdoor Outlets. Outdoor receptacle outlets shall be installed in accordance with 560.6(E)(1) through (E)(3).

Informational Note: See 210.8(A)(3)

(1) One-Family and Two-Family Dwellings. For a one-family dwelling and each unit of a two-family dwelling that is at grade level, at least one receptacle outlet readily accessible from grade and not more than 6½ ft. above grade level shall be installed at the front and back of the dwelling.

(2) Multifamily Dwellings. For each dwelling unit of a multifamily dwelling where the dwelling unit is located at grade level and provided with individual exterior entrance/egress, at least one receptacle outlet readily accessible from grade and not more than 6½ ft. above grade level shall be installed.

(3) Balconies, Decks, and Porches. Balconies, decks, and porches that are attached to the dwelling unit and are accessible from inside the dwelling unit shall have at least one receptacle outlet accessible from the balcony, deck, or porch. The receptacle shall not be located more than 6½ ft. above the balcony, deck, or porch walking surface.

(F) Laundry Areas. In dwelling units, at least one receptacle outlet shall be installed in areas designated for the installation of laundry equipment.

Exception No. 1: A receptacle for laundry equipment shall not be required in a dwelling unit of a multifamily building where laundry facilities are provided on the premises for use all by all building occupants,

Exception No. 2: A receptacle for laundry equipment shall not be required in other than one-family dwellings where laundry facilities are not to be installed or permitted.

(G) Basements, Garages, and Accessory Buildings. For a one-family and two-family dwelling, at least one receptacle outlet shall be installed in the areas specified in 560.6(G)(1) through (3). These receptacles shall be in addition to receptacles required for specific equipment.

(1) Garages. In each garage at least one receptacle outlet shall be installed in each vehicle bay and not more than 5½ ft. above the floor.

(2) Accessory Buildings. In each accessory building with electric power.

(3) Basements. In each separate unfinished portion of a basement

(H) Hallways. In dwelling units, hallways of 10 ft. or more in length shall have at least one receptacle outlet.

As used in this subsection, the hallway length shall be considered the length along the centerline of the hallway without passing through a doorway.

(I) Foyers. Foyers that are not part of a hallway in accordance with 560.6(H) and that have an area that is greater than 60 ft² shall have a receptacle(s) located in each wall space 3 ft. or more in width. Doorways, door side windows that extend to the floor,

and similar openings shall not be considered wall space.

560.7 Lighting Outlets Required. Lighting outlets shall be installed where specified in 560.7(A), (B), and (C).

(A) Dwelling Units. In dwelling units, lighting outlets shall be installed in accordance with 560.7(A)(1), (A)(2), and (A)(3).

(1) Habitable Rooms. At least one wall switch-controlled lighting outlet shall be installed in every habitable room, kitchen and bathroom.

Exception No. 1: In other than kitchens and bathrooms, one or more receptacles controlled by a wall switch shall be permitted in lieu of lighting outlets.

Exception No. 2: Lighting outlets shall be permitted to be controlled by occupancy sensors that are (1) in addition to wall switches or (2) located at a customary wall switch location and equipped with a manual override that will allow the sensor to function as a wall switch.

(2) Additional Locations. Additional lighting outlets shall be installed in accordance with the following.

(1) At least one wall switch-controlled lighting outlet shall be installed in hallways, stairways, and garages.

(2) For dwelling units, garages, at least one wall switch-controlled lighting outlet shall be installed to provide illumination on the exterior side of outdoor entrances or exits with grade level access. A vehicle door in a garage shall not be considered as an outdoor entrance or exit.

(3) Where one or more lighting outlet(s) are installed for interior stairways, there shall be a wall switch at each floor level, and landing level that includes an entryway, to control the lighting outlet(s) where the stairway between floor levels has six risers or more.

Exception to (A)(2)(1), (A)(2)(2), and (A)(2)(3): In hallways, in stairways, and at outdoor entrances, remote, central, or automatic control of lighting shall be permitted.

(4) At least one wall switch-controlled lighting outlet shall be installed in clothes closets over 25 ft². Closet luminaires shall be permanently installed lighting outlets.

(5) At least one wall switch-controlled lighting outlet shall be installed over each laundry tub, and any sink or basin whose room or area dimensions are greater than 164 ft². Such lighting outlets shall be in addition to the general lighting outlets installed in those room(s) or area(s).

(3) Storage or Equipment Spaces. For attics, underfloor spaces, utility rooms, and basements, at least one lighting outlet containing a switch or controlled by a wall switch shall be installed where these spaces are used for storage or contain equipment requiring servicing. At least one point of control shall be at the usual point of entry to these spaces. The lighting outlet shall be provided at or near the equipment requiring servicing.

(B) Emergency Systems. For multifamily dwelling units containing five or more units, in addition to the lighting outlets required in 560.7(A)(2), lighting outlets shall be installed in accordance with Article 700. The lighting outlets required to illuminate corridors and stairwells may be connected to a photocell located in the area to be illuminated if adequate natural illumination is present during daylight hours to illuminate those areas. Time clocks shall not be used. These emergency lights shall supplement normal lighting in stairwells and corridors.

High rise buildings containing dwelling use type units shall comply with 700.30 and 700.65.

Exception: On existing buildings not exceeding four stories in height containing only vertical stairwells (no corridors) all of the stairwell lights may be connected to the emergency service. Normal lighting will not be required in these stairwells.

Part III. Branch-Circuit, Feeder, and Service Calculations

560.8 Scope. 560.9 to 560.21 provide the requirements for computing branch-circuit, feeder, and service loads.

560.9 Calculations.

(A) Voltages. Unless other voltages are specified in this chapter, for purposes of computing branch-circuit and feeder loads, nominal system voltages of 120, 120/240, 208Y/ 120, and 240 volts shall be used.

(B) Fractions of an Ampere. Except where computations result in a fraction of an ampere 0.5 or larger, such fractions shall be permitted to be dropped.

560.10 Computation of Branch Circuit Loads. Branch-circuit loads shall be computed as shown in (A) and (B) of this section.

(A) Lighting Load. A unit load of not less than 3VA shall constitute the minimum lighting load for each square foot of floor area. The floor area for each floor shall be computed from the outside dimensions of the building, dwelling unit, or other area involved. The computed floor area shall not include open porches, garages, or unused or unfinished spaces not adaptable for future use.

(B) Other Loads. The minimum load for each outlet for general-use receptacles and outlets not used for general illumination shall not be less than that computed in (1) through (5) of this subsection, the loads shown being based on nominal branch-circuit voltages.

(1) Specific Appliances or Loads. An outlet for a specific appliance or other load not covered in (2) through (5) of this subsection shall be computed based on the ampere rating of the appliance or load served.

(2) Electric Dryers and Household Electric Cooking Appliances. Load computations shall be permitted as specified in 560.18 for electric dryers and 560.19 for electric ranges and other cooking appliances.

(3) Motor Loads. Outlets for motor loads shall be computed in accordance with the requirements in 430.22 and 430.24 and Article 440.

(4) Recessed Lighting Fixtures. An outlet supplying recessed lighting fixture(s) shall be computed based on the maximum volt-ampere rating of the equipment and lamps for which the fixture(s) is rated.

(5) Dwelling Occupancies. In one-family, two-family, and multifamily dwellings and in guest rooms of hotels and motels, the outlets specified in (a), (b), and (c) of this subsection are included in the general lighting load calculations of 560.9. No additional load calculations shall be required for such outlets.

a. All general-use receptacle outlets of 20-ampere rating or less, including receptacles connected to the circuits in 560.5(C)(3).

b. The receptacle outlets specified in 560.6(E) and (G).

c. The lighting outlets specified in 560.7(A) and (B).

560.11 Maximum Loads. The total load shall not exceed the rating of the branch circuit and it shall not exceed the maximum loads specified in (A) through (C) of this section, under the conditions specified therein.

(A) Motor-Operated and Combination Loads. Where a circuit supplies only motor-operated loads, Article 430 shall apply. Where a circuit supplies only air-conditioning equipment, refrigerating equipment, or both, Article 440 shall apply. For circuits supplying loads consisting of motor-operated utilization equipment that is fastened in place and that has a motor larger than $\frac{1}{8}$ hp. in combination with other loads, the total computed load shall be based on 125 percent of the largest motor load plus the sum of the other loads.

(B) Inductive and LED Lighting Loads. For circuits supplying lighting units that have ballasts, transformers, autotransformers, or LED drivers, the computed load shall be based on the total ampere ratings of such units and not on the total watts of the lamps.

(C) Range Loads. It shall be permissible to apply demand factors for range loads in accordance with Table 220.55, including Note 4.

560.12 Computed Load of Feeders and Services. The computed load of a feeder or service shall not be less than the sum of the loads on the branch circuits supplied, as determined by 560.7 through 560.10 after any applicable demand factors permitted by 560.12 through 560.20 have been applied.

560.13 General Lighting. The demand factors specified in Table 560.12 shall apply to that portion of the total branch-circuit load computed for general illumination. They shall not be applied in determining the number of branch circuits for general illumination.

Type of Occupancy	Portion of Lighting Load to Which Demand Factor Applies (Volt-Amperes)	Demand Factor Percent)
Dwelling units	20,000 or less	100
	Next 100,000 at	35
	Remainder over 120,000 at	25
Hotels and motels including apartment houses without provision for cooking by tenants*	First 20,000 or less at	50
	Next 80,000 at	40
	Remainder over 100,000 at	30

*The demand factors of this table shall not apply in the computed load of feeders or services supplying areas in hotels, and motels where the entire lighting is likely to be used at one time, as in ballrooms or dining rooms.

Table 560.13. Lighting Load Demand Factors

560.14 Motors. Motor loads shall be computed in accordance with 430.22, 430.24, 430.25, and 430.26.

560.15 Fixed Electric Space Heating. Fixed electric space heating loads shall be computed at 100 percent of the total connected load; however, in no case shall a feeder or service load current rating be less than the rating of the largest branch circuit supplied.

Exception: Where reduced loading of the conductors results from units operating on duty-cycle, intermittently, or from all units not operating at one time, the authority having jurisdiction may grant permission for feeder conductors to have an ampacity less than 100 percent, provided the conductors have an ampacity for the load so determined.

560.16 Small Appliance and Laundry Loads.

(A) Small Appliance Circuit Load. In each dwelling unit, the load shall be computed at 1500 volt-amperes for each 2-wire small-appliance branch circuit required by 560.5(C)(1). Where the load is subdivided through two or more feeders, the computed load for each shall include not less than 1500 volt-amperes for each 2-wire small-appliance branch circuit. These loads shall be permitted to be included with general lighting load and subjected to the demand factors provided in Table 560.13.

Exception: The individual branch circuit permitted by 560.6(B)(1), Exception No. 2 shall be permitted to be excluded from the calculation required by 560.16.

(B) Laundry Circuit Load. A load of not less than 1500 volt-amperes shall be included for each 2-wire laundry branch circuit installed as required by 560.5(C)(2). This load shall be permitted to be included with the general lighting load and subjected to the demand factors provided in Table 560.13.

560.17 Appliance Load. It shall be permissible to apply a demand factor of 75 percent to the nameplate rating load of four or more appliances fastened in place, other than electric ranges, clothes dryers, space-heating equipment, or air-conditioning equipment, that are served by the same feeder or service in a one-family, two-family, or multifamily dwelling.

560.18 Electric Clothes Dryers. The load for household electric clothes dryers in a dwelling unit(s) shall be 5000 watts (volt-amperes) or the nameplate rating, whichever is larger, for each dryer served. The use of the demand factors in Table 220.54 shall be permitted. Where two or more single-phase dryers are supplied by a 3-phase, 4-wire feeder or service, the total load shall be computed on the basis of twice the maximum number connected between any two phases.

560.19 Electric Ranges and Other Cooking Appliances. The demand load for household electric ranges, wall-mounted ovens, counter-mounted cooking units, and other household cooking appliances individually rated in excess of 1¾ kW shall be permitted to be computed in accordance with Table 220.55. Where two or more single-phase ranges are supplied by a 3-phase, 4-wire feeder or service, the total load shall be computed on the basis of twice the maximum number connected between any two phases. Kilovolt-amperes (kVA) shall be considered equivalent to kilowatts (kW) for loads computed under this section.

560.20 Noncoincident Loads. Where it is unlikely that two dissimilar loads will be in use simultaneously, it shall be permissible to omit the smaller of the two loads(s) in computing the total load of a feeder or service.

560.21 Feeder or Service Neutral Load.

(A) Basic Calculation. The feeder or service neutral load shall be the maximum unbalance of the load determined by this article. The maximum unbalanced load shall be the maximum net calculated load between the neutral conductor and any one ungrounded conductor.

Exception: For 3-wire, 2-phase or 5-wire, 2-phase systems, the maximum unbalanced load shall be the maximum net calculated load between the neutral conductor and any one ungrounded conductor multiplied by 140 percent.

(B) Permitted Reductions. A service or feeder supplying the following loads shall be permitted to have an additional demand factor of 70 percent applied to the amount in 560.21(B)(1) or portion of the amount in 560.21(B)(2) determined by the following basic calculations:

(1) A feeder or service supplying household electric ranges, wall-mounted ovens,

counter-mounted cooking units, and electric dryers, where the maximum unbalanced load has been determined in accordance with Table 220.55 for ranges and Table 220.54 for dryers

(2) That portion of the unbalanced load in excess of 200 amperes where the feeder or service is supplied from a 3-wire dc or single-phase ac system; or a 4-wire, 3-phase system; or a 3-wire, 2-phase system; or a 5-wire, 2-phase system

(C) Prohibited Reductions. There shall be no reduction of the neutral or grounded conductor capacity applied to the amount in 560.21(C)(1), or portion of the amount in (C)(2), from that determined by the basic calculation:

(1) Any portion of a 3-wire circuit consisting of 2 ungrounded conductors and the neutral conductor of a 4-wire, 3-phase, wye-connected system

(2) That portion consisting of nonlinear loads supplied from a 4-wire, wye-connected, 3-phase system

Informational Note: A 3-phase, 4-wire, wye-connected power system used to supply power to nonlinear loads may necessitate that the power system design allow for the possibility of high harmonic neutral-conductor currents

Part IV. Services and Service Disconnecting Means

560.22 Services and Service-Entrance Conductors.

(A) General. Services shall comply with the requirements of Article 230.

(B) Size and Rating of Service Conductors.

(1) General. The ampacity of the service-entrance conductors before the application of any adjustment or correction factors, shall not be less than either (a) or (b) of this subsection. Loads shall be calculated in accordance with Article 220. Allowable ampacity shall be determined from Article 310.

(2) Continuous and Noncontinuous Loads. Continuous and noncontinuous loads shall be calculated in accordance with either (a) or (b) below.

(a) The sum of the noncontinuous loads plus 125% of continuous loads.

(b) The sum of the noncontinuous load plus the continuous load if the service entrance conductors terminate in an overcurrent device that is listed for operations at 100% of its rating.

(3) Ungrounded Conductors. Ungrounded conductors shall have an ampacity of not less than the minimum rating of the disconnecting means specified in 230.79.

(4) Grounded Conductors. The grounded conductor shall not be less than the minimum size as required by 250.24(B). Grounded conductors shall be the same size as the ungrounded conductors for all services up to and including 400 amperes.

560.23 Service Disconnecting Means.

(A) General. Means shall be provided to disconnect all conductors from the service-entrance conductors.

(B) Location. The service disconnecting means shall be installed in accordance with 560.23(B)(1), (B)(2), and (B)(3), (A)(4), and (A)(5).

(1) One-Family and Two-Family Dwelling Units. In a one-family and two-family dwelling unit(s) the service disconnecting means shall be installed at a readily accessible location in the basement or first floor area of a building or structure, within the main wall, at a point not exceeding 5 ft. from the point of entry. When the distance of the service raceway needs to exceed 5 ft. from the point of entry into the building, the service raceway shall conform to the requirements of 230.6. In an existing residential occupancy which has no basement or other available place accessible to all tenants, the disconnecting means may be located on an enclosed porch or other suitable location.

(2) In Other Than One-Family and Two-Family Dwelling Units. In other than one-family and two-family dwelling units, the service disconnecting means shall be installed at a readily accessible location either outside of a building or structure or inside the building or structure nearest the point of entrance of the service conductors.

(3) Bathrooms and Other Areas. Service disconnecting means shall not be installed in bathrooms nor located over laundry tubs, oil tanks, toilets, grease traps and the like.

(4) High Rise Building. In high rise buildings, the disconnecting means for the multiple services recognized by 230.2(B)(3), shall be located in a dedicated fire rated room as near as practical to the serving utility vault. The rooms for the "Main" service disconnecting means which serve the building common element loads shall have a 3 hour fire rating. These rooms shall be for the exclusive use of the electrical equipment. No water, drain pipes, or ventilating ducts shall pass through these rooms. The rooms for "Main" service disconnecting means shall be required for each tenant floor. These disconnects may be located on a floor other than the floors served.

Where more than one service is permitted to serve one floor, the various disconnecting means, and their locations shall be prominently identified as required by 230.2.

(5) Multiple Occupancy Buildings. Each occupant shall have access to his service disconnecting means. In a multiple occupancy building supplied by a single service with a common accessible space available, the disconnecting means may consist of no more than six switches which shall be in accordance with the requirements of 230.71.

(C) Marking. Each service disconnect shall be permanently marked to identify it as a service disconnect.

(D) Rating of Service Disconnecting Means. The service disconnecting means shall have a rating not less than the load to be carried, determined in accordance with Article 220. In no case shall the rating be lower than specified in (1), (2), (3), or (4) of this subsection.

(1) One-Circuit Installation. For installations to supply only limited loads of a single branch circuit, the service disconnecting means shall have a rating of not less than 30 amperes.

(2) Two-Circuit Installations. For installations consisting of not more than two 2-wire branch circuits, the service disconnecting means shall have a rating of not less than 30 amperes.

(3) One-Family Dwelling. For a one-family dwelling, the service disconnecting means shall have a rating of not less than 100 amperes, 3-wire.

(4) All Others. For all other installations, the service disconnecting means shall have a rating of not less than 60 amperes.

560.24 Metering. Where a current supply is separately metered as in an apartment building, each such separately metered load shall be equipped with a meter disconnecting means which will disconnect the separately meter load from its source of supply. Such disconnect(s) shall conform to provisions of Part VI of Article 230.

Meters and disconnects shall be grouped and shall be located in meter closets if they are not installed in the basement. In all cases, the meter disconnect shall be immediately adjacent to its own meter. However where six or less meters are installed outside the building the foregoing provisions shall not apply, and in such cases the meter disconnects shall be installed in accordance with 560.23.

14E-5-570 Requirements for Existing Dwelling-Type Occupancies Not Exceeding Four Stories in Height

The following language shall be inserted as a new Article 570:

"570 Requirements for Existing Dwelling Units in Buildings Not Exceeding Four Stories In Height

570.1 Scope. This article covers the electrical requirements, installation requirements, and connection requirements for an existing dwelling unit in a building not exceeding four stories in height, including an existing dwelling unit in a building of mixed occupancy not exceeding four stories in height, and the common areas serving those dwelling units, when the alterations, remodeling, or repairs do not encompass 60% or more of the building structure, dwelling unit, or electrical system.

570.2 Not Covered. Dwelling occupancies not covered in 570.1 shall comply with Article 560 and other applicable articles of this Code.

570.3 General. All electrical installations, alterations and repairs shall be performed by an electrical contractor.

570.4 Permits. The electrical contractor shall obtain an electrical permit for all electrical work to be performed. Electrical permits shall be obtained before any work is started.

570.5 Plans. All plans and load calculations required by 215.5 shall be submitted before any electrical work is started. All plans and load calculations are subject to field inspection.

570.6 Electrical Heating. All electrical heat installations and conversions shall conform to the provisions of Articles 422 and 424.

570.7 Emergency Lighting. All buildings which contain five or more dwelling units shall conform to the provisions of Article 700, as they apply to emergency lighting requirements.

570.8 Ground Fault Circuit-Interrupter Protection for Personnel. All 125-volt, single phase, 15- and 20-ampere receptacle outlets installed in bathrooms, garages, counter top spaces, unfinished basements and outdoor locations shall have ground fault circuit interrupter protection for personnel.

570.9 Minimum Standards. When alterations, remodeling, or repairs encompass less than 60% of a building structure, dwelling unit, or electrical system, the wiring serving such building or structure shall conform to (a), (b), and (c) of this section.

(a) Any part of the building structure, dwelling unit, or electrical system upon which alterations, remodeling, or repairs are performed shall comply with the provisions of 570.10(A) through (I) and the other applicable sections of this *Code*.

(b) For existing dwelling occupancies not exceeding four stories in height or in the residential portion of an existing building of mixed occupancy not exceeding four stories in height, the portion of the building being altered, remodeled, or repaired shall comply with the provisions of 570.10(A) through (I).

In addition, there shall be a minimum of 60 amperes supply for each altered, remodeled, or repaired dwelling unit that is not a hotel or motel guest room.

Informational Note: Mixed occupancies include but are not limited to, mixed commercial and dwelling types.

(c) Simple repairs that do not involve structural alterations, such as replacing non-functioning switches, shall comply with the provisions of 570.10 (A), (B), (G), (H) and (I).

570.10. Specific Requirements.

(A) Ampacity Requirements. All existing electrical service, feeders, branch circuits, or system and equipment grounding, required to meet the standards set forth in this section shall be in an approved, acceptable condition and shall be of adequate ampacity for the load being served. For the purposes of this requirement, any existing electrical service being altered, remodeled or repaired shall be a minimum of 60 amperes supply for each dwelling unit that is not a hotel or motel guest room.

(B) Overcurrent Protection. All over-current protection required to meet the standards set forth in this section shall be of the proper size. When plug fuses are utilized, they shall be "Type S."

(C) Branch Lighting Circuits. Each dwelling unit shall be provided with a minimum of one 15-ampere general lighting branch circuit for each 46.5 m² (500 ft²) of living space. This branch circuit may supply the general use receptacle outlets.

(D) Small Appliance Branch Circuits. Each dwelling unit shall be provided with a minimum of one 20-ampere small appliance branch circuit to supply a minimum of two receptacle outlets serving countertops in each kitchen. This circuit shall be permitted to

also serve a laundry receptacle.

(E) Receptacle Outlet Requirements. An adequate number of receptacle outlets shall be provided in every habitable room of each dwelling unit to eliminate the need for the use of cord extension wiring. The minimum number of receptacle outlets required for various sized rooms is shown in Table 570.10.

Receptacle outlets serving kitchen countertops shall be ground-fault circuit-interrupter protected. At least one ground-fault circuit-interrupter protected wall mounted receptacle outlet shall be installed in each bathroom adjacent to the basin.

(F) Lighting Outlets Required. At least one wall switch-controlled lighting outlet shall be installed in each habitable room. Closets shall be adequately illuminated and shall contain light fixtures with a completely enclosed lamp, unless adequate illumination is supplied from adjacent fixtures outside the closet.

(G) Covers. All electrical boxes and outlets shall be provided with approved covers or plates.

(H) Smoke Alarms. Smoke alarms as required by the *Chicago Building Code* shall be installed. All smoke alarms shall be approved.

(I) Carbon Monoxide Detectors. Carbon monoxide detectors as required by the *Chicago Building Code* shall be installed. All carbon monoxide detectors shall be approved.

Table 570.10 Minimum Receptacle Outlets Required

Room Size	Minimum Receptacle Outlets Required
1 to 64 ft ² (example 8 ft x 8 ft)	2, on opposite walls
65 to 100 ft ² (example 10 ft x 10 ft)	3, on adjacent walls
greater than 100 ft ² (example 12 ft x 12 ft)	1 on each wall

* Where a straight wall exceeds 20 ft, a minimum of one receptacle outlet shall be provided for every 18 ft of that wall.

570.11 Wiring Methods. In addition to those wiring methods recognized in Chapter 3, the following wiring method is recognized as suitable:

Trade size $\frac{3}{8}$ flexible metal conduit or listed MC cable may be used for extensions to general lighting or appliance branch circuits not exceeding 20 amperes. Trade size $\frac{3}{8}$ flexible metal conduit and MC cable extensions are permitted between an existing outlet and two new outlets located in new or existing walls or partitions. Installation of trade size $\frac{3}{8}$ flexible metal conduit and MC cable extensions shall be permitted in lengths up to 7.62 m (25 ft). The number of conductors permitted in a trade size $\frac{3}{8}$ flexible metal conduit extension shall conform to Table 570.11. All flexible metal conduit shall contain a properly sized equipment grounding conductor sized to Table 250.122.

Table 570.11 Maximum Number of Insulated Conductors in Trade Size ¾ Flexible Metal Conduit*

Size (AWG)	Fitting Location	Type			
		RFH-2, SF-2	TF, XHHW, TW	TFN, THHN, THWN	FEP, FEBP, PF, PGF
18	Inside Conduit	2	3	5	5
	Outside Conduit	3	5	8	8
16	Inside Conduit	1	3	4	4
	Outside Conduit	2	4	6	6
14	Inside Conduit	1	2	3	3
	Outside Conduit	2	3	4	4
12	Inside Conduit	-	1	2	2
	Outside Conduit	-	2	3	3
10	Inside Conduit	-	1	1	1
	Outside Conduit	-	1	1	2

*In addition, one insulated, covered, or bare equipment grounding conductor of the same size shall be permitted."

14E-5-590 Temporary Installations

The provisions of Article 590 are adopted by reference with the following modifications:

Insert new Part II to read:

"Temporary Booths or Exhibits Inside of Buildings

590.10 Connections to Building Systems. No exhibitor shall make any electrical installation to, or alteration of the permanent wiring inside of a building.

590.11 Qualified Person. All electrical connections to the building electrical system or extensions thereto shall be made under the supervision and direction of a qualified person.

590.12 Extensions from the Building System. Extensions from the building electrical system shall be made by one of the approved wiring methods in Chapter 3, or shall be made by flexible multi-conductor cord, with grounding conductor, rated for extra-hard usage. All extensions shall comply with 590.6.

590.13 Terminations. Terminations of extensions to the building electrical system shall be enclosed in assemblies specifically approved for the purpose by the authority having jurisdiction.

590.14 Cords Above Floor Level. Cords rated a minimum of hard usage shall be permitted to be used above floor level.

590.15 Arrangement of Cords. All cords shall be arranged in lengths and patterns, in a workmanlike manner, to avoid excess cord hazards.

590.16 Grounding. All flexible multiconductor cords shall have a grounding conductor

and be rated for extra-hard usage or hard usage as permitted in 590.12 and 590.14, unless the cord is a component of an approved assembly.

590.17 Traffic Area. No cord shall be run across any space where subject to traffic unless the cord is enclosed in a substantial enclosure specifically approved for the purpose.

590.18 Cord Overcurrent Protection. All cords shall be protected by a properly sized overcurrent device.

590.19 Approval. For the purposes of this Article, all electrical equipment or appliances connected to the building electrical system or extensions thereto in booths or displays shall be:

(1) Listed and labeled in accordance with 110.3; or

(2) Specifically approved by the authority having jurisdiction and subject to field inspection.

Informational Note: An unlisted foreign luminaire is an example of material which would require specific approval under (2) of this section.

590.20 Permanent Wiring. Wiring permanently installed on all booths or displays including prewired booths brought in for connection to the building electrical system shall be enclosed in a raceway as allowed by a wiring method recognized in Chapter 3. Where flexibility is necessary, such as between booth sections and at connection points to the building electrical system or supply points, properly rated cord in lengths not to exceed 1.83 m (6 ft) and equipped with approved attachment plugs shall be permitted to be utilized.

590.21 Splices. All splices and terminations shall be made in approved metal enclosures.

590.22 Supports. No electrical equipment shall be attached to or supported by either dividers or curtains.

590.23 Fastened in Place. All electrical equipment shall be securely fastened in place using a recognized method.

Informational Note: Velcro, glue, tape, or similar methods are not suitable as a means of attachment.

590.24 Live Parts. There shall be no exposed energized current-carrying metal parts.

590.25 Exposed Metal Parts. All exposed noncurrent-carrying parts of the installations shall be effectively grounded in accordance with Article 250 of this Code.

590.26 Combustible Material. No electrical equipment or appliance which, under normal operating conditions, attains a surface temperature in excess of 90°C (194°F) shall be mounted on or supported from any combustible material, unless separated therefrom by a substantial noncombustible material.

590.27 Lighting Fixtures. Lighting fixtures or other appliances or equipment having other than a cord as outlined in 590.12 through 590.15 shall be permitted to be accepted provided the complete assembly, including the cord, is listed and labeled in accordance with 110.3.

590.28 Custom Displays. Unlabeled custom-made light fixtures and displays shall be permitted when fabricated using all listed and labeled components. Fabrication shall be by an electrical contractor. All equipment of this type shall be specifically approved by the authority having jurisdiction and shall be subject to field inspection.

590.29 Overcurrent Protection. All show wiring and related electrical equipment shall be provided with proper overcurrent protection as required in this *Code*.

590.30 Class 2 Wiring. All open class 2 wiring shall conform to Articles 725 of this *Code* and shall be fed from an approved Class 2 power source. For the purposes of this section only, a required non-interchangeable overcurrent device allowed to establish a Class 2 circuit shall be as follows:

0-15 volts – 5 amperes
15-30 volts – 3 amperes
30-60 volts – 1½ amperes.

590.31 Low-Voltage Wiring. All wiring and equipment not conforming to 590.30 shall be wired in accordance with 590.20 through 590.29 and Article 411 of this *Code*.”

Insert new Part III to read:

“Signs

590.40 Disconnect. All signs shall have a readily accessible disconnect.

590.41 Transformers and Cords. Transformers and cords shall be approved in accordance with 110.3.

590.42 Enclosures. All splices between supply conductors and transformer primary leads shall be enclosed in a listed enclosure. If the display is custom made, the enclosure shall be a minimum No. 12 gauge sheet metal or the equivalent and shall be free from sharp edges. All custom made enclosures are subject to field inspection.

590.43 Splices. Splices between secondary transformer leads and neon tube conductor shall be adequately insulated and enclosed in a listed metal enclosure.

590.44 Protective Enclosure. Neon sign displays which are erected at a height of 2.4 m (8 ft) or below shall be provide with a protective plexiglass shield. The protective shield shall be mounted and arranged to provide adequate ventilation.

Exception: The required shield shall be permitted to be omitted when in the opinion of the authority having jurisdiction, equivalent means of protection are provided.

590-45 Grounding. Grounding and bonding shall comply with the requirements of Article 250.”

CHAPTER 14E-6 SPECIAL EQUIPMENT

14E-6-600 Electric Signs and Outline Lighting

The provisions of Article 600 of NFPA 70 are adopted by reference with the following modifications:

Revise section 600.3 by adding new subsection (C) to read:

“Existing signs. Unlisted signs constructed or erected prior to February 7, 2002, shall comply with Chapter 14-36 of the *Chicago Building Code*, 1999 edition.”

Revise subsection 600.9(A) to read:

“Vehicles. Sign or outline lighting system equipment shall be at least 4.9 m (16 ft) above areas accessible to vehicles unless protected from physical damage.

Informational Note: See Chapter 13-20, Article XIII, of the *Chicago Building Code*.”

Insert new section 600.25 to read:

“Connections. Where signs are connected to previously installed branch circuits, the electrical contractor connecting the sign will be held responsible for the condition of the branch circuit. Connections shall not be made unless the branch circuit referred to is of sufficient capacity, in good condition, and in compliance with this Code. Signs may be connected to existing interior lighting circuits (except circuits feeding show windows) provided the combined load on the circuit does not exceed 1440 volt-amperes.

All outside wiring for signs shall be installed in rigid metal conduit, intermediate metal conduit, or electrical metallic tubing which shall be made waterproof; provided, however, for swinging signs the conduit or electrical metallic tubing shall terminate at the level of the crane within 914 mm (3 ft) of the sign and flexible conduit or other approved means shall be used to complete the connection. The flexible conduit shall have a drip loop and be arranged as not to bring moisture into the sign.

Sign branch circuits shall be installed so that the load connected shall in no case be more than 80% of the 15- or 20- ampere branch circuit overcurrent protective device.

Branch circuit conductors for each section of attraction board signs shall be routed to the distributing center of the section in rigid metal conduit, intermediate metal conduit or electrical metallic tubing.”

Insert new section 600.26 to read:

“Floodlights, Spotlights, and Flashing Lights. No floodlight or spotlight shall be installed in or on any sign in such a manner as to be detrimental to automobile or street traffic. The use of the colors, green, red, or amber is restricted to those signs where the use of such colors does not create a traffic hazard. Under no conditions shall flashing lights be used on a sign where they can be construed as traffic regulation or judged to be distracting to motor vehicle traffic.”

Insert new section 600.27 to read:

“Detailed Drawings. Detailed drawings shall be submitted with all sign permit applications. Each drawing shall contain the following information:

- (1) Test laboratory listing number
- (2) Manufacturers name or trademark
- (3) Size in feet and inches
- (4) Weight in pounds
- (5) Volt-ampere load
- (6) Branch circuit(s) required
- (7) Scaled graphical drawing of sign
- (8) Elevation showing the location of sign
- (9) Engineered drawing number (where required in Section 600.28)

Informational Note: See Chapter 13-20, Article XIII, of the *Chicago Building Code*.”

Insert new section 600.28 to read:

“Engineered Drawings Required. Drawings prepared by an architect or structural engineer, licensed to practice in the State of Illinois, and bearing the seal of the architect or engineer are required for and shall be presented with the applications for permits for the erection or alteration of signs, signboards, or structures which fall into the following categories:

- (1) Supported by a canopy
- (2) Requiring a roof structure which extends more than 3.66 m (12 ft) from the roof to the top of the structure or if any face of a sign mounted on a roof structure exceeds 5.57 m² (60 ft²) in area
- (3) Projecting signs which exceed 454 kg (1000 lbs) in weight or 9.20 m² (99 ft²) in area of one face
- (4) Signs held by diverging guys or supports at angles less than 45 degrees with the sign.
- (5) Projecting signs having more than 50% of the vertical dimension of the sign above the roof line and having any face that exceeds 5.57 m² (60 ft²) in area
- (6) Cranes supported by roof structures, providing the area of the sign exceeds 5.57 m² (60 ft²)
- (7) Signs supported by other than chains which have any face which exceeds 3.72 m² (40 ft²) in area
- (8) Signs erected entirely above the roof of a building
- (9) Supported from the ground by independent structure(s) with a top which is more than 7.32 m (24 ft) above the level of the adjoining street or surrounding grade
- (10) Installation of new sign boxes or letters on an existing structure, canopy, or beams where the existing structure, canopy, or beams had previously required such drawings
- (11) Flat signs which exceed 454 kg (1000 lb) in weight
- (12) Where, in the opinion of the Building Department, the erection or alteration of signs, signboards or supporting structures is not contained in or covered by this *Code*

All corrections made on rejected engineered drawings shall bear the architect or engineer’s signature, thus attesting to the corrections.”

Insert new sections 600.43 through 600.50 to read:

600.43 Switches on Doors. Doors or covers giving access to uninsulated parts of signs, or outline lighting systems exceeding 600 volts nominal, and accessible to the general public, shall either be provided with interlock switches which, on the opening of the doors or covers, disconnect the primary circuit, or shall be so fastened that the use of other than ordinary tools will be necessary to open them.

600.44 Fixed Outline Lighting and Skeleton-Type Signs for Interior Use.

(A) Tube Support. Gas tubing shall be supported independently of the conductors by means of insulators of noncombustible, non-absorptive materials such as glass, or porcelain or by suspensions from suitable wires or chains.

(B) Transformers. Transformers shall be installed in metal enclosures and as near as practicable to the gas tubing system.

(C) Supply Conductors. The supply conductors for the transformers shall be enclosed in grounded metal raceway.

(D) High-Tension Conductors. High-tension conductors shall be insulated for the voltage of the circuit and shall be enclosed in an approved raceway.

Exception: Conductors not exceeding 1.22 m (4 ft) in length between as tubing and adjacent metal enclosures shall be permitted to be enclosed in continuous glass or other insulating sleeves.

600.45 Window-Type Gas Tube Sign for Show Windows and Interior Use. This section shall apply to the installation and use of window-type gas tube signs.

(A) Location. Window gas tube signs shall be for indoor use only.

(B) Transformer. The transformer shall be in a metal enclosure.

(C) Supply Conductors. Supply conductors shall consist of hard or extra-hard usage-type cord containing an equipment grounding conductor. The cord shall not exceed 1.8 m (6 ft) in length.

(D) High-Voltage Conductors. High-voltage conductors shall be as short as practicable, but not more than 1.8 m (6 ft) long and shall be located where not subject to mechanical injury, and shall be insulated for the voltage of the circuit and be protected by continuous glass or other insulating sleeves or tubing.

(E) Grounding. Transformers and attached noncurrent-carrying metal parts shall be grounded in accordance with Article 250.

(F) Support. Window-type indoor signs shall be held in place by not more than two open hooks attached to the transformer case.

(G) Permit. Window-type indoor signs shall be installed only under the authority of a permit issued to an electrical contractor.

600.46 Supports. Any sign or device covered by Article 600 Part II shall be supported by approved fastening means as described in other sections of this Code.

600.47 Receptacles. No receptacles shall be installed in any sign or device covered by this section of the chapter.

600.48 Modular Signs. Where a sign is made up of several pieces the wiring to and between such pieces shall be enclosed in a metal raceway unless specifically approved by special permission.

600.49 Length of Cord. Where flexible cord is used as the method of supplying current to any device or sign covered by this section of the chapter, such cord shall not exceed 1.8 m (6 ft) in length. All such cords shall be approved three conductors and shall be equipped with a ground-type plug.

600.50 Voltage. In no case shall primary voltage to any sign or device covered by Article 600 Part II exceed 150 volts between conductors.”

Insert new parts III through IV to read:

“Part III. 600 Volts, Nominal, or Less

600.60 Installation of Conductors.

(A) Wiring Method. Conductors shall be installed in rigid or flexible metal conduit, intermediate metal conduit, electrical metallic tubing, mineral-insulated metal-sheathed cable, and metal poles complying with all requirements of 410.30(B). Aerial feeders to signs shall not be permitted.

(B) Insulation and Size. Conductors shall be of a type listed for the purpose and shall not be smaller than 14 AWG.

Exception No. 1: Conductors not smaller than 18 AWG of a type listed in Table 402.3 shall be permitted:

(a) As short leads permanently attached to lampholders or electric-discharge ballasts.

(b) As leads not more than 2.44 m (8 ft) long permanently attached to electric-discharge lampholders or electric-discharge ballasts if the leads are enclosed in wiring channels.

(c) For signs with multiple incandescent lamps requiring one conductor from a control to one or more lamps whose total load does not exceed 250 watts, if in an approved cable assembly of two or more conductors.

Exception No. 2: Conductors not smaller than 20 AWG shall be permitted as short leads permanently attached to synchronous motors.

(C) Exposed to Weather. Conductors in rigid conduit, electrical metallic tubing, flexible metal conduit, or in metal trough, raceways, or enclosures, exposed to the weather shall be of a type listed in 310.10(C).

(D) Number of Conductors in Raceway. The number of conductors in a raceway for sign fixtures shall be in accordance with Article 900.

(E) Conductors Soldered to Terminals. Where the conductors are fastened to lampholders other than of the pin type, they shall be soldered to the terminals or made with wire connectors, and the exposed parts of conductors and terminals shall be treated to prevent corrosion. Where the conductors are fastened to pin-type lampholders that protect the terminals from the entrance of water and that have been found acceptable for sign use, the conductors shall be of the stranded type but shall not be required to be soldered to the terminals.

Part IV. Hanging Flat and Projecting Signs

600.70 Support.

(A) Flat Signs. Flat signs shall be anchored below roof line except that additional support other than chain may be provided over parapet to roof.

(B) Projecting Signs. Projecting signs exceeding 9.3 m² (100 ft²) in area of one face shall be rigidly hung on beams. Separate projecting signs so hung as to appear as one sign shall be rigidly hung on beams if the total area of all faces on one side of the sign exceeds 9.3 m² (100 ft²).

600.71 Bracing.

(A) Chain, Side Guys, and Rigid Brace Supports. All projecting signs shall have standard chain supports and fastenings to the building as shown in Table 600.71(A). Fastenings shall be so installed that attached supports or guys make an angle of 45° or greater with the sign. Where machine or lag screws enter strong structures, anchorage will be considered as equivalent to bolt throughout the wall. Expansion bolts shall be not less than 10 mm (3/8 in.) in diameter and shall enter through brick or stone walls not less than 64 mm (2 1/2 in.). Lag bolts in solid woodwork shall be not less than 10 mm (3/8 in.) in diameter and shall enter woodwork not less than 76 mm (3 in.).

[Remainder of Page Intentionally Left Blank]

Table 600.71(A) Support Chains

Weight of Sign (lb)	Number of Chains	Trade Size of Chains	Fastening to Wall
Up to 75	1	4/0	Two expansion bolts per chain
76 to 150	2	4/0	Two expansion bolts per chain
151 to 400	2	8/0	One expansion bolts per chain
401 to 1,000	2	10/0	One expansion bolts per chain

(B) Supporting Chain. No supporting chain shall be attached back of the center of gravity of the sign, except in the case of the rear supports of vertical signs.

(C) Lift Chain. Each lift chain shall be capable of carrying the sign alone. Fastenings for signs, supports or guys shall not be attached to, or rest on, parapet walls and shall be not less than 203 mm (8 in.) from any corner of the building.

(D) Projecting Signs. All projecting signs shall have standard chain side guys or rigid brace supports as shown in Tables 600.71(D)(1), (2), or (3).

Table 600.71(D)(1) Number and Size of Chain Guys for Each Side of Guy

Height in Feet	Horizontal Length of Sign in Feet																
		1	2	3	4	5	6	7	8	9	10	11	12	13	14	15	16
1	No. Size	1 4/0	1 4/0	1 4/0	1 4/0	1 4/0	1 4/0	1 4/0	1 4/0	1 4/0	2 4/0	2 4/0	2 4/0	2 4/0	2 4/0	2 4/0	2 4/0
2	No. Size	1 4/0	1 4/0	1 4/0	1 4/0	1 4/0	1 4/0	1 4/0	1 4/0	2 4/0	2 4/0	2 4/0	2 4/0	2 4/0	2 4/0	2 4/0	2 4/0
3	No. Size	1 4/0	1 4/0	1 4/0	1 4/0	1 4/0	1 4/0	2 4/0	2 4/0	2 4/0	3 4/0	3 4/0	3 4/0	3 4/0	3 4/0	3 4/0	3 4/0
4	No. Size	1 4/0	1 4/0	2 4/0	2 4/0	2 4/0	2 4/0	2 4/0	2 4/0	2 4/0	3 4/0	3 4/0	3 4/0	3 4/0	3 4/0	4 4/0	4 4/0
5	No. Size	2 4/0	2 4/0	2 4/0	2 4/0	2 4/0	2 4/0	2 4/0	3 4/0	3 4/0	4 4/0	4 4/0	4 4/0	4 4/0	4 4/0	4 4/0	4 4/0
6	No. Size	2 4/0	2 4/0	2 4/0	2 4/0	2 4/0	3 4/0	3 4/0	4 4/0	4 4/0	4 4/0	4 4/0	4 4/0	3 8/0	3 8/0	3 8/0	3 8/0
7	No. Size	2 4/0	2 4/0	2 4/0	2 4/0	2 4/0	3 4/0	3 4/0	4 4/0	4 4/0	4 4/0	4 4/0	3 8/0	3 8/0	3 8/0	3 8/0	3 8/0
8	No. Size	2 4/0	2 4/0	2 4/0	2 4/0	3 4/0	3 4/0	4 4/0	4 4/0	4 4/0	4 4/0	3 8/0	3 8/0	3 8/0	3 8/0	4 8/0	4 8/0
9	No. Size	2 4/0	2 4/0	2 4/0	2 4/0	3 4/0	3 4/0	4 4/0	4 4/0	3 8/0	3 8/0	3 8/0	3 8/0	3 8/0	4 8/0	4 8/0	4 8/0
10	No. Size	2 4/0	2 4/0	2 4/0	2 4/0	3 4/0	3 4/0	4 4/0	4 4/0	3 8/0	3 8/0	3 8/0	4 8/0	4 8/0	4 8/0	4 8/0	4 8/0

Table 600.71(D)(2) Capacity in Square Feet of Sign Surface for Pipe Braces

Trade Size of Pipe (in.)	Outside Diameter of Pipe (in.)	Length of Brace in Feet																
		3	4	5	6	7	8	9	10	11	12	13	14	15	16	17	18	19
½	.082	38	22	15														
¾	1.03			40	28	15												
1	1.29					54	33	18										
1¼	1.65							70	53	37	21							
1½	1.89										56	42	23					
2	2.36													78	60	25		
2½	2.86																95 48	

Table 600.71(D)(3) Capacity in Square Feet of Sign Surface for Angle Iron Braces

Dimension of Angle Iron in Inches	Length of Brace in Feet														
	4	5	6	7	8	9	10	11	12	13	14	15	16	17	18
1 x 1 x 3/16	12														
1½ x 1½ x 3/16	37	20													
1½ x 1½ x 3/16	57	41	25	8											
1½ x 1½ x 3/16			61	28	12										
2 x 2 x 3/16				49	32	16									
2½ x 2½ x 3/16						58	41	25							
3 x 3 x ½										92	56	24			
3½ x 3½ x ½													77	42	9
4 x 4 x ½															59

Note 1. There shall not be more than 40 ft² to one brace.

Note 2. Pipe braces shall not have joints near center.

Note 3. The ends of the pipe shall be closed by welding or by the use of an approved fitting.

(E) Hinged Projecting Signs. Projecting signs with chain or rigid pipe side guys shall be hinged at the building so that, should the sign swing on account of loosening of the side guys, no undue strain will be placed on the supporting bolts. Where the length of the hanger iron projecting from the sign frame is of a length that will not permit hinging due to the interference of the sign drum with the supporting wall said wall connections shall be made by means of two anchor bolts in the wall for each hanger iron, and the wall plates shall be fastened with not less than two bolts to the iron frame of the sign.

(F) Side Guy Chain. Each chain used for the support of for the side guy of sign shall have an independent attachment to the building or supporting structure, and shall make an angle of 45° or greater with the sign.

(G) Supporting Chains. Where supporting chains are attached to bolts through the wall such bolts shall be not less than 16 mm (5/8 in.) in diameter. The bolt shall be anchored

by a washer plate of not less than 610 mm² (24 in.²) of surface and of not less than 3.2 mm (1/8 in.) thick.

(H) Window Frames or Sills. Chains or signs shall not be fastened to window frames or sills.

(I) Turnbuckle. A turnbuckle shall be provided for all supporting chains and side guys. Turnbuckles shall have a breaking strength equivalent to that of the chain to which they are attached and shall be not less than 4.8 mm (3/16 in.).

(J) Split Links. Split links used for connections of chains shall be of standard design and shall have a breaking strength at least equivalent to that of the chain to which they are attached.

(K) Corrosion Protection. All chains, turnbuckles, split links, bolts and screws, and all other devices which support or form part of the support of a sign shall be galvanized or otherwise suitably protected from corrosion in some approved manner.

(L) Saddling. Where necessary to use a saddle for the fastening of a building iron, rigid construction shall be used. Chains will not be approved.

(M) Machine Screws. Machine screws in iron fronts shall be not less than 1/2 in. in diameter and shall pass through iron work.

(N) Wooden Bays. Projecting signs, lift chains or guys shall not be attached to wooden bays.

600.80 Swinging Signs. Swinging signs shall be supported by a pipe crane, or the equivalent, as shown in Table 600.80.

Swinging signs having a length of more than 2.44 m (8 ft) shall have not less than three hanging irons. Not less than two bolts shall be used to fasten strap to hanging iron. All cranes shall be further supported by an additional lift chain not more than 610 mm (2 ft) from building. No crane shall be erected higher than 8.53 m (28 ft) above the public way.

Table 600.80 Swinging Sign Supports

Weight	Pipe Size
0-75 lb	1 in.
76-150 lb	1 1/4 in.
151-300 lb	1 1/2 in.
301-450 lb	2 in.
451-1000 lb	2 1/2 in.

600.90 Supporting Poles or Posts. Supports for signs shall be either steel beams, round steel pipe sections or square steel (hollow) sections.

(A) Single Supporting Member. Signs which have a single supporting member shall be restricted to round steel pipe sections or square steel sections. The sections may

consist of a fabricated and welded assembly, provided the welding is performed by a certified welder.

(B) Minimum Support. The minimum requirements for the support of signs shall be based upon a combined torsional and bending moment for a wind pressure of 1440 Pa (30 psf) and sign weight involved, using a maximum fiber stress of 138,000 kPa (20,000 psi).

(C) Drawing. A sketch, or engineer's drawings where required by this Code, shall accompany each permit application. The sketch or drawing shall show complete and detailed information of the construction and installation of the sign.

(D) Design Values. The values listed in Tables 600.90(A) and (B) are minimum and are based upon an elevation of not more than 3.7 m (12 ft) above the surrounding grade or ground level to the bottom of the sign. The dimensions of the sign shall be such that a ratio between the two dimensions of the sign shall not exceed two to one. The distance between the center line of the support and the sign edge shall not exceed 750 mm (30 in.) for projecting signs. Deviation from the provisions of this section may be permitted by special permission, provided drawings are submitted from a structural engineer licensed to practice in the State of Illinois. Such drawings must attest to the fact that the proposed installation is equal to or greater than the standard required by this section.

Table 600.90(D)(1) Minimum Support Size for Projecting Signs

Area of One Face in ft ²	Round Pipe in Inches	Square Tubular Section in Inches
Up to 10	4 (.237 wall)	3 x 3 x 1/4
11 to 20	6 (.280 wall)	4 x 4 x 3/16
21 to 30	8 (.250 wall)	5 x 5 x 1/4
31 to 40	8 (.250 wall)	6 x 6 x 1/4
41 to 50	8 (.322 wall)	7 x 7 x 1/4
51 to 60	10 (.250 wall)	8 x 8 x 1/4
61 to 70	10 (.365 wall)	8 x 8 x 1/4
71 to 75	10 (.365 wall)	10 x 10 x 1/4

Table 600.90(D)(2) Minimum Support Size for Concentrically Mounted Signs

Area of One Face in ft ²	Round Pipe in Inches	Square Tubular Section in Inches
Up to 10	4 (.237 wall)	3 x 3 x 1/4
11 to 20	5 (.258 wall)	4 x 4 x 3/16
21 to 30	6 (.280 wall)	5 x 5 x 1/4
31 to 40	8 (.280 wall)	6 x 6 x 1/4
41 to 50	8 (.322 wall)	7 x 7 x 1/4
51 to 60	10 (.250 wall)	8 x 8 x 1/4
61 to 70	10 (.368 wall)	8 x 8 x 1/4
71 to 75	10 (.365 wall)	8 x 8 x 1/4

600.100 Obstructions

(A) Obstructions. Signs shall not obstruct or be attached to any part of a fire escape, and where a sign is hung near a fire escape, it shall be arranged to swing away from such fire escape.

(B) Clearance from Conductors. Signs shall be installed so that a clearance of not less than 900 mm (3 ft) is maintained between any wire of a high potential circuit and the sign, sign support, or sign guy. Similar clearance of not less than 300 mm (12 in.) shall be maintained between any other municipal or public utility wire. Sign hangers shall make arrangements to have wires rerouted when necessary before the sign is hung.

(C) Windows. Signs covering windows used for required natural light or required natural ventilation will not be approved without special permission.

600.110 Roof Structures. Roof structures shall be installed when the required 45° angle of the lift chain cannot be made of the building wall. Roof structures less than 3.7 m (12 ft) shall conform to Figure 600.110.

Where the height does not exceed 3.7 m (12 ft) for signs up to 3.7 m² (40 ft²) in area the main angles shall be 2" x 2" x 1/4" and the intermediate angles shall be 1 1/2" x 1 1/2" x 3/16"; for signs over 3.7 m² (40 ft²) in area the main angles shall be 2 1/2" x 2 1/2" x 1/4" and the intermediate angles shall be 2" x 2" x 1/4". Roof structures over 3.7 m (12 ft) high or more than 5.6 m² (60 ft²) shall have engineer's drawings required by 600.28.

Figure 600.110 Roof Structures

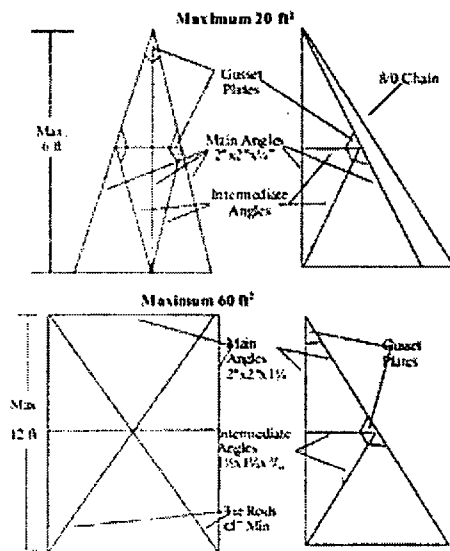

600.120 Catwalks and Ladders

(A) Catwalks. Catwalks for maintenance purposes on signs and sign structures shall be constructed of metal.

(B) Ladder on Sign Structures. Ladder on sign structures shall be at least 375 mm (15

in.) wide. Ladders on signs shall be metal and shall be not less than 250 mm (10 in.) wide. Horizontal projecting signs, the bottoms of which are more than 8.5 m (28 ft) above the public way, shall be provided with catwalks and handrails.

(C) Horizontal Flat Signs. Horizontal flat signs, the bottoms of which are more than 8.5 m (28 ft) above the public way shall be provided with catwalks and handrails unless signs can be maintained by means other than ladders supported from the way.

(D) Vertical Signs. Vertical signs, the bottoms of which are more than 8.5 m (28 ft) above the public way, or with a vertical dimension of more than 7.5 m (25 ft), shall have ladders the full vertical distance of the sign. In addition, all signs in the above category which are more than 1.2 m (4 ft) wide shall be provided with a steel structure at the top of the sign for maintenance purposes.”

14E-6-604 Manufactured Wiring Systems

The provisions of Article 604 of NFPA 70 are not adopted.

14E-6-605 Office Furnishings

The provisions of Article 605 of NFPA 70 are adopted by reference with the following modification:

1. Revise subsection 605.8 to read:

“Freestanding-Type Office Furnishings.

(A) Connection to Building System. Office furnishings of the free-standing type (not fixed) shall be permitted to be connected to the building electrical system by one of the wiring methods of Chapter 3.

(B) Internal Partition Wiring. All internal wiring to the partitions shall be installed with a recognized wiring method. Where tight turns are encountered, 3/8” or 1/2” trade size flexible metal conduit may be installed. Where flexible metallic conduit is installed, a separate green grounding conductor of the wire type, shall be installed in the flexible metal conduit, and shall also bond all of the metal boxes together.

Exception: Where bends of a radius less than that available with 3/8” or 1/2” trade size flexible metal conduit, listed and labeled super flexible metallic conduit with nylon jackets conductors maybe used.”

14E-6-610 Cranes and Hoists

The provisions of Article 610 of NFPA 70 are adopted by reference with the following modification:

Revise section 610.11 to read:

“Wiring Method. Conductors shall be enclosed in metal raceways, or be Type MC cable or Type MI cable unless otherwise permitted or required in 610.11(A) through (E).

(A) Contact Conductor. Contact conductors shall not be required to be enclosed in raceways.

(B) Exposed Conductors. Short lengths of exposed conductors at resistors, collectors, and other equipment shall not be required to be enclosed in raceways.

(C) Flexible Connections to Motors and Similar Equipment. Where flexible connections are necessary, flexible stranded conductors shall be used. Conductors shall be in flexible metal conduit, liquidtight flexible metal conduit, multiconductor cable, or an approved metallic flexible raceway.

(D) Pushbutton Station Multiconductor Cable. Where multiconductor cable is used with a suspended pushbutton station, the station shall be supported in some satisfactory manner that protects the electrical conductors against strain.

(E) Flexibility to Moving Parts. Where flexibility is required for power or control to moving parts, listed festoon cable or a cord suitable for the purpose shall be permitted, provided the following apply:

(1) Suitable strain relief and protection from physical damage is provided.

(2) In Class I, Division 2 locations, the cord is approved for extra-hard usage.”

14E-6-620 Elevators, Dumbwaiters, Escalators, Moving Walks, Platform Lifts, and Stairway Chairlifts

The provisions of Article 620 of NFPA 70 are adopted by reference with the following modification:

Revise section 620.21 to read:

“Wiring Methods. Conductors and optical fibers located in hoistways, in escalator and moving walk wellways, in platform lifts, stairway chairlift runways, machinery spaces, control spaces, in or on cars, in machine rooms and control rooms, not including the traveling cables connecting the car or counterweight and hoistway wiring, shall be installed in rigid metal conduit, intermediate metal conduit, electrical metallic tubing, or metal wireways, or shall be Type MI cable unless otherwise permitted in 620.21(A) through (C).

(A) Elevators.

(1) Hoistways and Pits.

(a) Cables used in Class 2 power-limited circuits shall be permitted, provided the cables are supported and protected from physical damage and are of a jacketed and flame-retardant type.

(b) Flexible cords and cables that are components of listed equipment and used in circuits operating at 30 volts rms or less or 42 volts dc or less shall be permitted in lengths not to exceed 1.8 m (6 ft) provided the cords and cables are supported and protected from physical damage and are of a jacketed and flame-retardant type.

(c) The following wiring methods shall be permitted in the hoistway in lengths not to exceed 1.8 m (6 ft):

- (1) Flexible metal conduit
- (2) Liquidtight flexible metal conduit
- (3) Flexible cords and cables, or conductors grouped together and taped or corded, shall be permitted to be installed without a raceway. They shall be located to be protected from physical damage and shall be of a flame-retardant type and shall be part of the following:
 - a. Listed equipment
 - b. A driving machine, or
 - c. A driving machine brake

Exception to 620.21(A)(1)(c)(1), (2), and (3): The conduit length shall not be required to be limited between risers and limit switches, interlocks, operating buttons, and similar devices.

(d) A sump pump or oil recovery pump located in the pit shall be permitted to be cord connected. The cord shall be a hard usage oil-resistant type, of a length not to exceed 1.83 m (6 ft), and shall be located to be protected from physical damage.

(2) Cars.

(a) Flexible metal conduit, and liquidtight flexible metal conduit of metric designator 12 (trade size $\frac{3}{8}$), or larger, not exceeding 1.8 m (6 ft) in length, shall be permitted on cars where so located as to be free from oil and if securely fastened in place.

(b) Hard-service cords and junior hard-service cords that conform to the requirements of Article 400 (Table 400.4) shall be permitted as flexible connections between the fixed wiring on the car and devices on the car doors or gates. Hard-service cords only shall be permitted as flexible connections for the top-of-car operating device or the car-top work light. Devices or luminaires shall be grounded by means of an equipment grounding conductor run with the circuit conductors. Cables with smaller conductors and other types and thicknesses of insulation and jackets shall be permitted as flexible connections between the fixed wiring on the car and devices on the car doors or gates, if listed for this use.

(c) Flexible cords and cables that are components of listed equipment and used in circuits operating at 30 volts rms or less or 42 volts dc or less shall be permitted in lengths not to exceed 1.8 m (6 ft) provided the cords and cables are supported and protected from physical damage and are of a jacketed and flame-retardant type.

(d) The following wiring methods shall be permitted on the car assembly in lengths not to exceed 1.8 m (6 ft):

- (1) Flexible metal conduit
- (2) Liquidtight flexible metal conduit
- (3) Flexible cords and cables, or conductors grouped together and taped or corded, shall be permitted to be installed without a raceway. They shall be located to be protected from physical damage and shall be of a flame-retardant type and shall be part of the

following:

- a. Listed equipment
- b. A driving machine, or
- c. A driving machine brake

(3) Within Machine Rooms, Control Rooms, and Machinery Spaces and Control Spaces.

(a) Flexible metal conduit, and liquidtight flexible metal conduit of metric designator 12 (trade size ¾) or larger, not exceeding 1.8 m (6 ft) in length, shall be permitted between control panels and machine motors, machine brakes, motor-generator sets, disconnecting means, and pumping unit motors and valves.

(b) Where motor-generators, machine motors, or pumping unit motors and valves are located adjacent to or underneath control equipment and are provided with extra-length terminal leads not exceeding 1.8 m (6 ft) in length, such leads shall be permitted to be extended to connect directly to controller terminal studs without regard to the carrying-capacity requirements of Articles 430 and 445. Auxiliary gutters shall be permitted in machine and control rooms between controllers, starters, and similar apparatus.

(c) Flexible cords and cables that are components of listed equipment and used in circuits operating at 30 volts rms or less or 42 volts dc or less shall be permitted in lengths not to exceed 1.83 m (6 ft), provided the cords and cables are supported and protected from physical damage and are of a jacketed and flame-retardant type.

(d) On existing or listed equipment, conductors shall also be permitted to be grouped together and taped or corded without being installed in a raceway. Such cable groups shall be supported at intervals not over 900 mm (3 ft) and located so as to be protected from physical damage.

(e) Flexible cords and cables in lengths not to exceed 1.8 m (6 ft) that are of a flame-retardant type and located to be protected from physical damage shall be permitted in these rooms and spaces without being installed in a raceway. They shall be part of the following:

- (1) Listed equipment
- (2) A driving machine, or
- (3) A driving machine brake

(4) Counterweight. The following wiring methods shall be permitted on the counterweight assembly in lengths not to exceed 1.8 m (6 ft):

- (1) Flexible metal conduit
- (2) Liquidtight flexible metal conduit
- (3) Flexible cords and cables, or conductors grouped together and taped or corded, shall be permitted to be installed without a raceway. They shall be located to be protected from physical damage, shall be of a flame-retardant type, and shall be part of the following:

- a. Listed equipment

- b. A driving machine, or
- c. A driving machine brake

(B) Escalators.

(1) Wiring Methods. Flexible metal conduit or liquidtight flexible metal conduit shall be permitted in escalator and moving walk wellways. Flexible metal conduit or liquidtight flexible conduit of metric designator 12 (trade size $\frac{3}{8}$) shall be permitted in lengths not in excess of 1.8 m (6 ft).

(2) Class 2 Circuit Cables. Cables used in Class 2 power-limited circuits shall be permitted to be installed within escalators and moving walkways, provided the cables are supported and protected from physical damage and are of a jacketed and flame-retardant type.

(3) Flexible Cords. Hard-service cords that conform to the requirements of Article 400 (Table 400.4) shall be permitted as flexible connections on escalators and moving walk control panels and disconnecting means where the entire control panel and disconnecting means are arranged for removal from machine spaces as permitted in 620.5.

(C) Platform Lifts and Stairway Chairlift Raceways.

(1) Wiring Methods. Flexible metal conduit or liquidtight flexible metal conduit shall be permitted in platform lifts and stairway chairlift runways and machinery spaces. Flexible metal conduit or liquidtight flexible conduit of metric designator 12 (trade size $\frac{3}{8}$) shall be permitted in lengths not in excess of 1.8 m (6 ft).

(2) Class 2 Circuit Cables. Cables used in Class 2 power-limited circuits shall be permitted to be installed within platform lifts and stairway chairlift runways and machinery spaces, provided the cables are supported and protected from physical damage and are of a jacketed and flame-retardant type.

(3) Flexible Cords and Cables. Flexible cords and cables that are components of listed equipment and used in circuits operating at 30 volts rms or less or 42 volts dc or less shall be permitted in lengths not to exceed 1.83 m (6 ft) provided the cords and cables are supported and protected from physical damage and are of a jacketed and flame-retardant type.”

14E-6-625 Electric Vehicle Charging Systems

The provisions of Article 625 of NFPA 70 are adopted by reference without modification.

14E-6-626 Electrified Truck Parking Spaces

The provisions of Article 626 of NFPA 70 are adopted by reference without modification.

14E-6-630 Electric Welders

The provisions of Article 630 of NFPA 70 are adopted by reference without modification.

14E-6-640 Audio Signal Processing, Amplification, and Reproduction Equipment

The provisions of Article 640 of NFPA 70 are adopted by reference with the following modifications.

Revise subsection 640.3(B) to read, with no exceptions or notes:

“Ducts, Plenums, and Other Air-Handling Spaces. Section 300.22(B) shall apply to circuits and equipment installed in ducts specifically fabricated for environmental air. Section 300.22(C) shall apply to circuits and equipment installed in other spaces used for environmental air (plenums).”

Revise subsection 640.23 to read:

“Conduit or Tubing. The number of conductors permitted in a single conduit or tubing shall not exceed the percentage fill specified in Table 1, Chapter 9.”

Revise subsection 640.24 to read:

“Wireways, Gutters, and Auxiliary Gutters. The use of metallic wireways, gutters, and auxiliary gutters shall be permitted for use with audio signal conductors and shall comply with applicable articles with respect to permitted locations, construction, and fill.”

14E-6-645 Information Technology Equipment

The provisions of Article 645 of NFPA 70 are adopted by reference with the following modifications:

Revise subsection 645.3(B) to read:

“Plenums. Section 300.22(C) shall apply to wiring and cabling in other spaces used for environmental air (plenums) in or above an information technology equipment room.”

Revise subsection 645.5(E) to read:

“Under Raised Floors. Power cables, communications cables, connecting cables, interconnecting cables, cord-and-plug connections, and receptacles associated with the information technology equipment shall be permitted under a raised floor, provided the following conditions are met:

(1) The raised floor is of approved construction, and the area under the floor is accessible.

(2) The branch-circuit supply conductors to receptacles or field-wired equipment are in rigid metal conduit, intermediate metal conduit, electrical metallic tubing, metal wireway, surface metal raceway with metal cover, flexible metal conduit, liquidtight flexible metal conduit, and associated metallic boxes or enclosures as permitted in Chapter 3. These supply conductors shall be installed in accordance with the requirements of 300.11.

(3) Ventilation in the underfloor area is used for the information technology equipment

room only, except as provided in 645.4(2). The ventilation system shall be so arranged, with approved smoke detection devices, that upon the detection of fire or products of combustion in the underfloor space, the circulation of air will cease.

(5) Openings in the raised floor for cords and cables protect cords and cables against abrasion and minimize the entrance of debris beneath the floor.

(6) Cables, other than those covered in 645.5(E)(2) and (E)(3), are one of the following:

a. Listed DP cable having adequate fire-resistant characteristics suitable for use under raised floors of an information technology equipment room.

b. Interconnecting cables enclosed in a raceway.

c. Equipment grounding conductors

Informational Note: One method of defining fire resistance is by establishing that the cables do not spread fire to the top of the tray in the "UL Flame Exposure, Vertical Tray Flame Test" in UL 1685-2011, Standard for Safety for Vertical-Tray Fire-Propagation and Smoke-Release Test for Electrical and Optical-Fiber Cables. The smoke measurements in the test method are not applicable.

Another method of defining fire resistance is for the damage (char length) not to exceed 4 ft. 11 in. when performing the CSA "Vertical Flame Test — Cables in Cable Trays," as described in CSA C22.2 No. 0.3-M-2001, Test Methods for Electrical Wires and Cables."

14E-6-646 Modular Data Centers

The provisions of Article 646 of NFPA 70 are not adopted.

14E-6-647 Sensitive Electronic Equipment

The provisions of Article 647 of NFPA 70 are adopted by reference without modification.

14E-6-650 Pipe Organs

The provisions of Article 650 of NFPA 70 are adopted by reference without modification.

14E-6-660 X-Ray Equipment

The provisions of Article 660 of NFPA 70 are adopted by reference without modification.

14E-6-665 Induction and Dielectric Heating Equipment

The provisions of Article 665 of NFPA 70 are adopted by reference without modification.

14E-6-668 Electrolytic Cells

The provisions of Article 668 of NFPA 70 are adopted by reference without modification.

14E-6-669 Electroplating

The provisions of Article 669 of NFPA 70 are adopted by reference without modification.

14E-6-670 Industrial Machinery

The provisions of Article 670 of NFPA 70 are adopted by reference without modification.

14E-6-675 Electrically Driven or Controlled Irrigation Machines

The provisions of Article 675 of NFPA 70 are adopted by reference without modification.

14E-6-680 Swimming Pools, Fountains, and Similar Installation

The provisions of Article 680 of NFPA 70 are adopted by reference with the following modification:

Revise section 680.11 to read:

“Underground Wiring Location. Underground wiring shall be permitted where installed in rigid metal conduit, intermediate metal conduit, rigid polyvinyl chloride conduit, or reinforced thermosetting resin conduit. Underground wiring shall not be permitted under the pool unless this wiring is necessary to supply pool equipment permitted by this article. The minimum cover depths shall be as given in Table 300.5.”

14E-6-682 Natural and Artificially Made Bodies of Water

The provisions of Article 682 of NFPA 70 are adopted by reference without modification.

14E-6-685 Integrated Electrical Systems

The provisions of Article 685 of NFPA 70 are adopted by reference without modification.

14E-6-690 Solar Photovoltaic (PV) Systems

The provisions of Article 690 of NFPA 70 are adopted by reference without modification.

14E-6-691 Large-Scale Photovoltaic (PV) Electric Power Production Facility

The provisions of Article 691 of NFPA 70 are adopted by reference without modification.

14E-6-692 Fuel Cell Systems

The provisions of Article 692 of NFPA 70 are adopted by reference without modification.

14E-6-694 Wind Electric Systems

The provisions of Article 694 of NFPA 70 are adopted by reference without modification.

14E-6-695 Fire Pumps

The provisions of Article 695 of NFPA 70 are adopted by reference with the following modifications:

Insert new section 695.3 to read:

“Power Sources for Electric Motor-Driven Fire Pumps. Electric motor-driven fire pumps shall have a reliable source of power in conformance with 695.3(A) and (B).

All primary sources shall have a high degree of reliability and be capable of carrying indefinitely the sum of the locked-rotor current of the fire pump motor(s) and the full-load current of the associated fire pump controller accessory equipment. These power sources, where required, shall be arranged so that a fire at one source will not cause an interruption at the other source.

Buildings having no required emergency system or only a System III emergency system, shall not be required to have a secondary source of power for the fire pump.

Informational Note: See Table 700.5 for Emergency Systems Required.

(A) Primary Source. Primary power shall be supplied by a separate, independent service with no disconnect, other than at the fire pump controller, from one of the following sources:

(1) Utility Service. Power shall be provided by a separate and independent utility service or, where special permission is obtained in writing from the authority having jurisdiction, an approved off-site primary electrical generating facility in common ownership with the building location of fire pump installation.

(2) On-Site Generation. Power shall be supplied by an approved primary power on-site generator conforming to the following:

- (a) The generator room and associated main distribution room shall be enclosed in separate rooms having 3-hour fire rated construction.
- (b) All openings into these rooms shall be protected by 3 hour (A-label) opening protective assemblies.
- (c) These rooms shall not be below grade.
- (d) These rooms shall be used for no other purpose than the primary generation and distribution of power.
- (e) If stored fuel is used there shall be kept available a 4-hour reserve of fuel at all times.

(B) Secondary Power. Secondary power shall be in accordance with 695.4(B) and be supplied as follows:

(1) Where Emergency System II is Required. The secondary source shall be as stated below in (a), (b), (c) and (d).

- (a) Where the normal building source is common to the Emergency System II auxiliary source, no secondary power shall be required for the fire pump.
- (b) Where the Emergency System II is served by two independent utility sources, the secondary source shall be that source which is not common to the primary fire pump source.

(c) In high rise buildings under 91 m (300 ft) in height, the secondary source shall be from an emergency source other than the source serving the fire pump.

(d) In high rise buildings 91 m (300 ft) or greater in height, the secondary source shall be from an on-site generator in conformance with 700.31 and 701.16.

Informational Note: See Table 700.5 for Emergency Systems Required.

(2) Where an Emergency System I is Required. The secondary source shall be from an approved on-site generator conforming to the requirements of 700.20, 700.50(1) and 701.16.

Informational Note: See Table 700.5 for Emergency Systems Required.

(3) Multi-Building Campus-Style Complexes with Fire Pumps. Where primary sources as described in 695.3(A) are not practicable and with special permission, two or more feeder sources shall be permitted as one power source where such feeder sources are connected to or are derived from separate utility services. The connection(s), overcurrent protective device(s), and disconnecting means for such feeders shall meet the requirements in 695.4(B)(1) or (B)(2), as applicable.

(4) Conditions. Whenever a secondary source is required by 695.3(B)(1) or (B)(2), all related following conditions shall be met:

(a) In addition to the required connected emergency loads, the generator, or other emergency source where allowed, is sized to carry indefinitely the sum of the locked-rotor current of the fire pump motor(s) and the full-load current of the associated fire pump controller accessory equipment.

(b) The fire pump feeder is served by a disconnect switch separate from all required emergency loads.

(c) The fire pump feeder is protected by overcurrent protection sized to carry indefinitely the sum of the locked-rotor current of the fire pump motor(s) and the full load current of the associated fire pump controller accessory equipment.

(d) The disconnect serving the fire pump shall be lockable in the closed position and be supervised as in 695.4(B)(5).

(5) Arrangement. The power sources shall be arranged so that a fire at one source will not cause an interruption at the other source.

Exception No. 1 to 695.3(B): An on-site or standby generator used to comply with this section shall be of sufficient capacity to allow normal starting and running of the motor(s) driving the fire pump(s) while supplying all other loads simultaneously operated load. Automatic shedding of one or more optional standby loads in order to comply with this capacity requirement shall be permitted. A tap ahead of the on-site generator disconnecting means shall not be required.

Exception No. 2 to 695.3(B): Where each electric motor-driven fire pump is provided with an approved parallel redundant engine-driven fire pump, which will automatically start upon failure of the electric motor-driven fire pump to start, the requirement for a secondary source of power shall be satisfied."

Revise subsection 695.4(B)(3)(e) to read:

“*Supervision.* The disconnecting means shall be supervised in the closed position by both of the following methods:

- (a) Local signaling service that will cause the sounding of an audible signal at a constantly attended point
- (b) Supervision by a required fire alarm system, when such system serves the building.”

Delete subsection 695.4(B)(3)(f).

4. Revise section 695.6 by replacing the first sentence and subsection (A) with the following, and renumbering subsections (B) through (J) as (C) through (K), respectively:

“**Power Wiring.** Power circuits and wiring methods shall comply with the requirements in 695.6(A) through (K), and as permitted in 230.90(A), Exception No. 4; 230.94, Exception No. 4; 240.13; 230.208; 240.4(A); and 430.31.

The conductors for the primary and secondary sources shall be separate and routed to maintain this separation. The supply conductors for the primary and secondary sources shall connect directly to a listed fire pump transfer switch.

(A) Service Conductors. Supply conductors shall be physically routed outside of all buildings and shall be installed as service entrance conductors in accordance with Article 230.

(1) Underground. These conductors shall be installed in conformance with Chapter 3.

(2) Overhead. Overhead service conductors shall comply with this *Code* and in addition shall comply with the following:

- (a) Conductors shall not pass over any combustible structure or material
- (b) Conductors shall not be attached to any combustible surface or material
- (c) Conductors shall not be attached to or run over any point of a building which is above an opening not protected by a labeled fire door, labeled fire window or labeled fire damper.

Where supply conductors cannot be physically routed outside buildings, they shall be permitted to be routed through building(s) where installed in accordance with Condition No. 1 or Condition No. 2 of 230.6. Where a fire pump is wired under the provisions of 695.3(B)(2), this requirement shall apply to all supply conductors on the load side of the service disconnecting means that constitute the normal source of supply to that fire pump.

Exception: Where there are multiple sources of supply with means for automatic connection from one source to the other, the requirement shall only apply to those conductors on the load side of that point of automatic connection between sources.

(B) Circuit Conductors. Fire pump supply conductors on the load side of the final disconnecting means and overcurrent device(s) permitted by 695.4(B) shall be kept entirely independent of all other wiring. They shall only supply loads that are directly associated with the fire pump system, and they shall be protected to resist potential damage by fire, structural failure, or operational accident.

They shall be permitted to be routed through building(s) encased in 50 mm (2 in.) of concrete or within enclosed construction dedicated to the fire pump circuit(s) and having a minimum of a 2-hour fire resistance rating, or they shall be permitted to be within electrical circuit protective systems listed to meet UL 1724 with a minimum of 2-hour fire resistance. The installation shall comply with any restrictions provided in the listing of the electrical circuit protective system used.”

CHAPTER 14E-7 SPECIAL CONDITIONS

14E-7-700 Emergency Systems

The provisions of Article 700 of NFPA 70 are not adopted. The following language is adopted as Article 700:

“Part I. General

700.1. Scope. The purpose of this article is to provide details for installation of required exit and emergency illumination systems in all buildings, new and existing.

The provisions of Article 700 are intended to provide a reasonably reliable alternate source of electrical power upon the failure of the normal source of supply. It is impossible to list all of the various means of accomplishing the desired results. Article 700 is intended to set a minimum standard for such installations.

Informational Note No. 1: For further information regarding wiring and installation of emergency systems in health care facilities, see Article 517.

Informational Note No. 2: For further information regarding performance and maintenance of emergency systems in health care facilities, see NFPA 99-2015, *Health Care Facilities Code*.

Informational Note No. 3: For specification of locations where emergency lighting is considered essential to life safety, see NFPA 101-2015, *Life Safety Code*.

Informational Note No. 4: For further information regarding performance of emergency and standby power systems, see NFPA 110-2013, *Standard for Emergency and Standby Power Systems*.

700.2. Definitions.

Auxiliary Source of Current Supply. The auxiliary source of current supply shall be another independent source of current supply, isolated from the normal source, either from the utility, an on-site generator, an inverter, or unit batteries where allowed in this article.

Emergency Lighting (Illumination) Systems. Emergency lighting systems shall be lighting systems required by this chapter which supplement the general lighting system.

Exit Lighting Systems. Exit lighting systems shall be those electrical systems which supply electricity to required exit, directional, stairway and fire escape signs.

Informational Note: See Sections 13-160-700 through 13-160-820 of the *Chicago Building Code* for location and type.

Emergency Systems. Emergency systems are intended to automatically supply illumination, power, or both, to designated areas and equipment in the event of failure of the normal supply or in the event of accident to elements of a system intended to supply, distribute, and control power and illumination essential for safety to human life.

Final Reserve Source of Current Supply. The final reserve source of current supply shall be an approved battery source, on-site generator installed in accordance with Article 701, or an approved on-site inverter system.

Normal Source of Current Supply. The normal source of current supply is that supply which furnishes electrical energy for general illumination and power purposes.

Relay, Automatic Load Control. A device used to set normally dimmed or normally-off switched emergency lighting equipment to full power illumination levels in the event of a loss of the normal supply by bypassing the dimming/switching controls, and to return the emergency lighting equipment to normal status when the device senses the normal supply has been restored.

Informational Note: See ANSI/UL 924, *Emergency Lighting and Power Equipment*, for the requirements covering automatic load control relays.

700.3 General. The provisions of this article shall be in addition to or amendatory of those set forth in Chapters 1 through 4 of this Code. Emergency and exit lighting systems shall not be intermingled with any other wiring system in the building except as otherwise allowed in this article.

700.4 Plan Submittal Procedure. No work shall start on the exit and emergency lighting systems before approved by the authority having jurisdiction.

In addition to any other information required by the authority having jurisdiction, the plans shall indicate:

- (a) The location of all exit and emergency lights on scaled floor plans of a scale not less than $\frac{1}{8}$ in. = 1 ft.
- (b) The location of all normal lights in areas with exit and emergency lights.
- (c) A single line drawing of the emergency service and distribution showing sizes of conduit, conductors, switches, and overcurrent devices.
- (d) Connected load of all branch circuit panels.
- (e) Information relative to generators as required in Section 701.6.

Exception No. 1: In new buildings, when the first tenant is entering a space, it shall not be necessary to submit the information required in (c) through (e) above, provided each plan indicates the reviewed plan number on which the information was previously submitted.

Exception No. 2: It shall be the responsibility of the plan applicant to determine the adequacy of an existing emergency service and distribution. The details of this service and distribution, in (c) above, need not be shown when it is stated by the submitter that the existing emergency system

is in conformance with this chapter. However, the drawings shall indicate the measured connected load for the affected emergency branch circuit panels, and the connected load for all additional circuits being altered or installed.

Part II. Emergency System Requirements

700.5 Type of Emergency Systems Required. The type of emergency system (I, II, or III) provided in buildings shall be as indicated in Table 700.5. All required emergency lights, exit, directional, stairway and fire escape signs in these buildings shall be supplied from the emergency system as required in this Article.

[Remainder of Page Intentionally Left Blank]

Table 700.5. Emergency System Type Required - By Use ^{9, 10}

Building Use / Type		Occupancy Class*	Application Provisions (Capacity, Height, Area)	System Type		
				I	II	III
Residential	Hotels / Motels	A	Two floor or more, or more than 20 persons		X	
	Non-transient Residential	A	5 or more dwelling units - see Articles 560 and 570			X
	Non-transient Residential	A	dormitories, group homes, fraternity and sorority houses - two floors or more, or more than 20 persons			X
	Non-transient Residential ¹	A	Over 80 feet but less than 300 feet in height		X ^{1, 6}	
	Non-transient Residential ¹	A	300 feet or more in height		X ⁶	
	Single Room Occupancy	A	See Chapter 13-206 **		X	
	Transient Residential	A	Two floors or more, or more than 20 persons		X	
Institutional	Ambulatory Health Care Facilities		B, E	See Article 517.	X ⁵	
	Day Care or Child Care Center	Institutional or 24 Hr.	B, C-3	2 floors or more, or more than 20 persons, or day care centers that operate between 9 p.m. and 6 a.m.	X	
		Type III School	C-3	See Chapter 13-56 **		X
	Homes for the Aged or Children	B	Two floors or more or more than 20 persons		X	
	Hospitals	B	Containing operating, delivery, or emergency rooms	X		
	Hospitals	B	Other than above		X ⁵	
Jails	B	Two floors or more, or more than 20 persons		X		
Nursing Homes, Convalescent Homes, Infirmaries, etc.	B	Two floors or more, or more than 20 persons		X		
Assembly	Places of Assembly ^{2, 4, 8}	C-2	50 to 99 persons			X
	Places of Assembly ^{2, 4, 8}	C-2	100 to 300 persons		X	
	Places of Assembly ^{2, 4, 8}	C-1	More than 300 persons	X		
	Schools up to 100 students	C-3				X

	Schools more than 100 students	C-3		X	
	School Auditoriums	C	Without fixed seats	X	
	School Auditoriums ⁸	C	With fixed seats		See Theaters
	Theaters ⁸	C	300 or fewer persons	X	
	Theaters ⁸	C	More than 300 persons	X	
Non-Residential	Office / Retail / Factory ³	E, F, G, H, I	10,000 square feet or more		X
	Office / Retail / Factory ³	E, F, G, H, I	Two or more stories / levels	X	
	Police Stations	J	Two floors or more, or more than 20 persons	X	
	Parking Facilities	H-3, J	See Chapter 13-96**		X
	Restaurants, Bars, Taverns	C-1, C-2, F			See Retail
High Rise	High Rise Buildings	any	Over 80 feet but less than 300 feet above grade	X ⁶	
	High Rise Buildings	any	300 feet or more in height	X ⁷	

* See Chapter 13-56 of the *Chicago Building Code*

** Chapters of the *Chicago Building Code*

Notes to Table 700.5

¹ All existing and newly constructed buildings having dwelling units, more than 80 feet above grade shall provide an approved, on-site auxiliary source of current supply for the egress lighting and exit signs.

² For the purposes of this Table, Places of Assembly (except as indicated for schools) shall include, but shall not be limited to, locations such as:

Airport Terminals	Churches / Chapels	Gymnasiums	Parish Halls
Auditoriums	Club Houses	Libraries	Swimming Pools
Assembly Halls	Dance Halls	Lodge Halls	
Banquet Halls	Exhibition Halls	Museums	

³ For the purposes of this table, Office / Retail / Factory shall include, but shall not be limited to, locations such as:

Automobile Agencies	Bookstores	Lumber Yards	Plants
Bakeries	Bowling Alleys	Meat Packing or Processing	Retail Stores
Banks	Broadcasting Studios	Motor Freight Docks	Vaults
Barber Shops	Factories	Office Buildings	Warehouses
Beauty Parlors	Frozen Food Lockers	Pet Shops	
Billiard Parlors	Laboratories		

⁴ For the purposes of this Table use of any room or space for assembly purposes by less than 50 persons in a building having other uses, and incidental to such other use, shall be classed as part of the other use and subject to the provisions applicable thereto.

⁵ The second source of current supply shall be an on-site generator or a battery system.

⁶ See 700.30.

⁷ The auxiliary source of current supply shall be from an on-site diesel generator. This shall apply to all buildings 91 m (300 ft) and over unless the building requires a System I under other uses.

⁸ Any building or space in this category where fixed seating is provided for the public or the occupants of the building during any performance or meeting shall be provided with a System I emergency system where having capacity for more than 300 persons and shall be provided with aisle lighting where having capacity for more than 150 persons. In buildings with multiple spaces containing fixed seats, the classification of the Emergency system shall be based on the total number of seats in the building. The aisle lighting requirement shall be based on the number of seats in each space.

⁹ Where System III is required, a System I or II may be installed. Where System II is required, a System I may be installed.

¹⁰ It is impossible to list each specific type of use and therefore some of the classifications are general. If there is any doubt concerning a particular building or use, consult the authority having jurisdiction.

700.6 Illumination Required.

(A) General. In general, every portion of a building devoted to the use or accommodation of occupants, including all assembly rooms, all means of egress leading to the streets, open courts, corridors, stairways, exits, emergency exit stairways, or any other part of the building used by occupants, shall be well illuminated in accordance with requirements for general illumination.

(B) Emergency. In addition, there shall be sufficient emergency illumination to enable occupants to evacuate the building without difficulty upon failure of the general illumination system.

The required emergency lighting and exit lighting systems shall be functional whenever the building is occupied.

Emergency lighting systems shall be designed and installed so that the failure of any individual lighting element, such as the burning out of a light bulb, cannot leave in total darkness any space that requires emergency illumination.

Exception: Except as allowed in 700.66(C)(6).

Where high-intensity discharge lighting such as high- and low-pressure sodium, mercury vapor, and metal halide is used as the sole source of normal illumination, the emergency lighting

system shall be required to operate until normal illumination has been restored.

Exception No. 1: In residential buildings, emergency fixtures which illuminate areas of a building with unobstructed natural illumination shall be permitted to be controlled by photocell(s). The photocell shall be permitted to control multiple fixtures as long as the photocell and the fixtures are located in the area with the natural illumination insuring that the illumination required in 700.11 is present in the space at all times.

Exception No. 2: In buildings with not more than 12 dwelling units and not greater than 4 stories above grade, with open exterior means of egress, emergency illumination shall not be required on the exterior portion of the means of egress, where sufficient general illumination is present. Similar buildings with more than 12 dwelling units or greater than four stories above grade may only omit exterior emergency illumination with special permission.

(C) Source. All buildings requiring emergency illumination as stated in 700.5 shall not rely solely upon electric utility power as a source.

Such buildings shall have an emergency system as called for in Table 700.5. In addition, if the auxiliary source is one of the sources listed in 700.33(A) through (G), an additional on-site source of power for the emergency lighting and exit lighting systems shall be required. This source of power shall be permitted to be:

- (1) A generator in conformance with 700.33(H)
- (2) An inverter system installed in accordance with 700.33(I)
- (3) Unit batteries conforming to 700.30(C), 700.43, and 700.44

All unit battery equipment shall comply with 700.66.

700.7 Expositions Halls, Schools, and Theaters.

(A) General. In the auditorium of a theater, school, or exposition building there shall be a sufficient number of emergency lighting outlets properly distributed to provide one foot-candle of illumination at all points on the floor area. In all parts of the building used by the occupants, alternate emergency lighting outlets shall be supplied through separate circuits.

(B) Aisle Lighting. Additional lighting outlets of an approved type on the emergency lighting system shall be placed in the aisles of an auditorium with fixed seats, as follows:

- (1) Where the aisles are smooth running ramps, aisle lighting outlets shall be placed at a minimum of every third row of seats.
- (2) In aisles in which there are steps, aisle lighting outlets shall be placed so as to illuminate each step.
- (3) Aisle lighting outlets on the opposite sides of an aisle shall be supplied through separate branch circuits.
- (4) Where aisle lighting outlets are only on one side of the aisle, alternate lights shall be on separate branch circuits.
- (5) Other listed systems which provide equivalent illumination shall be permitted. Such systems shall be supplied by more than one circuit so that the loss of a circuit would not leave the aisle or steps completely without illumination.

Exception No. 1: Auditoriums with a capacity for 150 or fewer persons shall not be required to

have additional aisle lighting outlets where there is an unobstructed direct line of sight to identified exits or exit corridors and all other required emergency illumination is present.

Exception No. 2: Where the fixed seating is of the type that can be reassembled for various layouts and the theater intends to change the layout for various performances, a flexible wiring method for aisle lighting shall be permitted where:

- (1) *The aisle lighting system complies with 700.7(B)*
- (2) *All associated aisle lighting cords are listed as "extra- hard usage"*
- (3) *All associated aisle lighting cord plug and receptacle connections are twist lock*
- (4) *All associated aisle lighting cords are of the minimum length needed for flexibility*
- (5) *Additional strain relief is provided around all associated aisle lighting cord and receptacle connections*
- (6) *The point of connection to the permanent emergency system is visibly identified and of the type that will not accept standard straight blade plugs*

A permit and inspection are required for all reconfiguration of seating prior to use.

Informational Note: This flexible allowance for aisle lighting is not intended and shall not be permitted as a permanent wiring method.

(C) Additional Locations. In addition to requirements of 700.7(A), emergency lighting shall be provided:

- (1) In the projection booth
- (2) At the lighting service equipment
- (3) At the stage lighting control equipment
- (4) In the room that contains the emergency lighting generator or the batteries

700.8 Hospitals. Where a System I is required, permanently connected emergency lights and the ungrounded electrical system (if installed) shall be supplied from the final reserve source of current supply in addition to the general lighting in all critical and special care areas. The final reserve source of current supply shall be a diesel generator in conformance with 700.33(H).

The emergency lights shall be adequate to illuminate these rooms for their normal use, and shall be completely separate from the general wiring systems. Switches to turn emergency lights "OFF" when a room is not in use shall be permitted to be installed for each individual room.

Informational Note: See Article 517 - Health Care Facilities.

700.9 Tenant Spaces in Multi-Use or Multi-Space Buildings. Emergency lighting shall be provided within a tenant space, other than a dwelling unit, exceeding 93 m² (1,000 ft²) in any building in which emergency lighting is required.

700.10 Emergency Lighting for Passenger Elevators. Unit batteries shall be provided for standby emergency illumination in the elevator car. Immediately after normal car lighting power fails, emergency lighting shall be provided in all elevators in accordance with Chapter 18-30 of the *Chicago Building Code*.

FPN: See the *Safety Code for Elevators and Escalators*, ASME A17.1 § 2.14.7.1 for further

information.

700.11 Intensity of Emergency Illumination. In general the required emergency illumination shall provide not less than one foot-candle of illumination on all points of all required areas.

Exception No. 1: As allowed by 13-160-670 or 13-160-680. Upon failure of the normal lighting system the emergency lighting shall be restored to full brilliance.

Exception No. 2: Where dimming of the emergency lighting below one foot-candle is required, the following shall apply:

- (1) Special permission shall be required.*
- (2) Upon failure of the normal lighting system the emergency lighting shall be restored to full brilliance.*
- (3) The emergency lighting shall not be dimmed below ½ foot-candle.*

700.12 Capacity of Emergency System. The exit and emergency system, service and feeders shall have a minimum capacity of 0.1 watts per square foot, based on the total square foot area of the building.

700.20 System I.

(A) Sources of Supply. System I shall consist of three sources of electrical energy supply as follows:

- (1) The normal source of current supply
- (2) An auxiliary source of current supply totally separate from the normal source
- (3) A final reserve source of current supply from batteries, from an on-site generator(s) in conformance with Article 701, or from an on-site inverter

(B) Sequence. System I shall have the following sequence of current supply to the emergency lights and exit signs:

- (1) The normal source of current supply
- (2) The auxiliary source of current supply upon failure of the normal source of current supply
- (3) The final reserve source of current supply upon failure of both the normal and the auxiliary sources of current supply

Informational Note: See Parts III and IV of this Article.

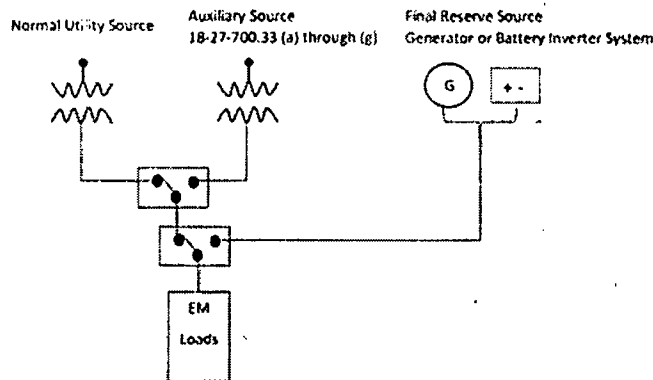

Figure 700.20 Typical System I Emergency System

700.21 System II.

(A) Sources of Supply. System II shall consist of two sources of electrical energy supply as follows:

- (1) The normal source of current supply
- (2) The auxiliary source of current supply

(B) Sequence. System II shall have the following sequence of current supply to the emergency lights and exit signs:

- (1) The normal source of current supply
- (2) The auxiliary or final reserve source of current supply upon failure of the normal current supply.
- (3) For emergency illumination and exit sign purposes, if the auxiliary source of current supply is not one of the sources listed in 700.33(H), 700.33(I), 700.30(C), or 700.43 an additional source which complies with 700.6(C) shall be provided.

Informational Note: See Figure 700.21-22

700.22 System III. System III shall consist of two sources of current supply as follows:

- (1) The normal source of current supply to the structure which shall provide for the general illumination
- (2) The second source of current supply shall provide electrical current supply for the emergency lighting and exit lighting systems and shall be either an auxiliary source in accordance with 700.33(H) or 700.33(I), or approved unit battery equipment in accordance with 700.43
- (3) A transfer switch shall not be required.

Informational Note: See Figure 700.21-22

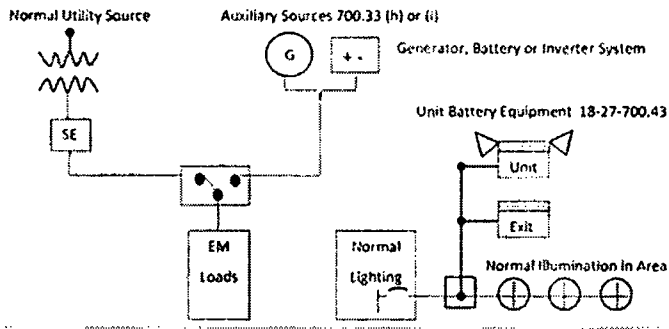

Figure 700.21-22 Typical of Either System II or System III Emergency Systems.

700.23 Transfer Equipment.

(A) General. Transfer equipment, including automatic transfer switches, shall be automatic, identified for emergency use, and approved by the authority having jurisdiction. Transfer equipment shall be designed and installed to prevent the inadvertent interconnection of normal and emergency sources of supply in any operation of the transfer equipment. Transfer equipment and electric power production systems installed to permit operation in parallel with the normal source shall meet the requirements of Article 705.

(B) Bypass Isolation Switches. Means shall be permitted to bypass and isolate the transfer equipment. Where bypass isolation switches are used, inadvertent parallel operation shall be avoided.

(C) Automatic Transfer Switches. Automatic transfer switches shall be electrically operated and mechanically held. Automatic transfer switches, rated 1000 VAC and below, shall be listed for emergency system use.

(D) Use. Transfer equipment for emergency illumination and exit signs shall supply only those loads.

(E) Documentation. The short-circuit current rating of the transfer equipment, based upon the specific overcurrent protection device type and settings protecting the transfer equipment, shall be field marked on the exterior of the transfer equipment.

700.24. Signals. Audible and visual signal devices shall be provided, where practicable, for the purpose described in 700.24(A) through (F).

(A) Malfunction. To indicate malfunction of the emergency source.

(B) Carrying Load. To indicate that the battery is carrying load.

(C) Not Functioning. To indicate that the battery charger is not functioning.

(D) Ground Fault. To indicate a ground fault in solidly grounded wye emergency systems of more than 150 volts to ground and circuit-protective devices rated 1000 amperes or more. The sensor for the ground-fault signal devices shall be located at, or ahead of, the main system disconnecting means for the emergency source, and the maximum setting of the signal devices shall be for a ground-fault current of 1200 amperes. Instructions on the course of action to be taken in event of indicated ground fault shall be located at or near the sensor location.

(E) Bypass Isolation. To indicate that the bypass isolation is in the bypass position.

(F) Remote Annunciation. Remote audible and visual annunciation of the transfer switch(es) at a common central manned location shall be installed where the transfer switches are not installed in a location that is manned at all times and the building is open.

Informational Note: For signals for generator sets, see NFPA 110-2013, Standard for Emergency and Standby Power Systems.

700.25 Signs.

(A) Emergency Sources. A sign shall be placed at the service-entrance equipment, indicating type and location of each on-site emergency power source.

Exception: A sign shall not be required for individual unit equipment as specified in 700.43.

(B) Grounding. Where removal of a grounding or bonding connection in normal power source equipment interrupts the grounding electrode conductor connection to the alternate power source(s) grounded conductor, a warning sign shall be installed at the normal power source equipment stating:

WARNING
SHOCK HAZARD EXISTS IF GROUNDING
ELECTRODE CONDUCTOR OR BONDING JUMPER
CONNECTION IN THIS EQUIPMENT IS REMOVED
WHILE ALTERNATE SOURCE(S) IS ENERGIZED.

The warning sign(s) or label(s) shall comply with 110.21(B).

700.26 Surge Protection. A listed SPD shall be installed in or on all emergency systems switchboard and panelboards.

700.28 Selective Coordination. Emergency system(s) overcurrent devices shall be selectively coordinated with all supply-side overcurrent protective devices.

Selective coordination shall be selected by a licensed professional engineer or other qualified persons engaged primarily in the design, installation, or maintenance of electrical systems. The selection shall be documented and made available to those authorized to design, install, inspect, maintain, and operate the system.

700.30 High Rise Buildings.

(A) Under 300 Feet In Height. In high rise buildings under 91 m (300 ft) in height, the auxiliary source of current supply to the emergency lighting and exit lighting systems shall be one of the following:

- (1) An on-site generator
- (2) A battery inverter system in conformance with 700.33(I)
- (3) A completely independent utility company primary and either or both:
 - (a) An on-site generator in conformance with Article 701
 - (b) A battery inverter system in conformance with 700.33(I)

Exception: Existing high rise buildings containing dwelling units may use unit battery equipment in conformance with the exception to 700.30(C) or an approved battery inverter system with a minimum capacity of 90 minutes.

(B) 300 Feet in Height and Over. In buildings 300 feet in height or greater, the auxiliary source of current supply to the emergency lighting and exit lighting systems shall be from an on-site diesel generator in conformance with Article 701.

(C) Dwelling Type Uses. New and existing high rise buildings that contain dwelling units shall have an on-site source of supply, independent from the utility source, for the emergency lighting and exit lighting systems. The on-site source of supply shall be a generator in conformance with 700.33(H) or an inverter system in conformance with 700.33(I).

Generators shall conform to the following:

- (1) High rise buildings under 91 m (300 ft) shall be permitted to have natural gas or diesel fuel as supply and shall comply with Article 701.
- (2) High rise buildings 91 m (300 ft) and over shall be required to have diesel fuel as the supply and shall comply with Article 701.

Exception No. 1: Approved unit battery equipment shall be permitted to supply the emergency lighting and exit lighting systems in existing buildings under 91 m (300 ft) that contain dwelling units, provided they comply with 700.43 and 700.66(C). Buildings undergoing 60% or more renovation of interior spaces or the electrical system shall not be included in this exception.

Exception No. 2: Approved unit battery equipment shall be permitted for the emergency illumination and exit signs in existing buildings 91 m (300 ft) and over that contain dwelling units provided that such equipment was installed prior to February 7, 2000.

Informational Note No. 1: The above exceptions do not relieve other Code requirements regarding elevators, sump pumps, fire alarms systems, etc.

Informational Note No. 2: See Section 13-76-080 of the *Chicago Building Code*.

All paths of egress that serve the dwelling units, or are common to both the dwelling units and other spaces in mixed occupancy buildings, shall meet the emergency illumination requirements of this subsection.

Part III. Approved Auxiliary Sources

700.33 Approved Auxiliary Sources. The auxiliary source of current supply for all emergency system installations shall comply with any one of the following conditions:

(A) Isolated Plant. When the normal source of current supply is an isolated plant, the auxiliary source of current supply shall be from an approved overhead or underground service from a utility company.

(B) Overhead Service. The auxiliary source of current supply shall be permitted to be from the same source of current supply as the normal source of current supply provided:

- (1) The normal source of current supply is an overhead service from the utility company

and no other utility source is available.

(2) The auxiliary source of current supply is from a different pole and is by separate drop, service conduit, and equipment as widely separated from the normal source of current supply as physical conditions permit.

(C) Separate Transformers. When the normal lighting and power supply is alternating current from separate transformers:

(1) The auxiliary source of current supply shall be permitted to be from an approved transformer or transformers within the building and supplied from the power service.

(2) The current supply to the transfer switch shall be taken from the first distribution point on the load side of the light and power service switches.

(D) Underground Network System. Where the source of current supply is common to both light and power and is a utility-supplied underground, 3 phase, network system fed from two or more generating or substations, the auxiliary source of current supply shall be permitted to be a separate service from the utility supplied underground network system. A transfer switch shall not be required.

(E) Spot Network. The auxiliary source of current supply shall be permitted to be a separate service where the source of current supply is common to both light and power, and is what is known as a "spot network" having:

(1) Two separate primaries

(2) Two utility company transformers

(3) Utility switchgear necessary to accomplish fully automatic switching in both directions. A transfer switch shall not be required.

(F) Common Source. Where the source of current supply is common to both light and power and consists of a single utility company primary supplying one or more transformers located on a pole structure or on a pad outside of the building being served, the auxiliary source of current supply shall be taken from the secondary side of the transformer or transformers through a separate set of service entrance conductors, a separate service conduit, a service switch and a ground. A transfer switch shall be required.

(G) Building Vault. Where the source of current supply is in a vault located inside of the building being served and the secondary leads are as short as possible, the emergency auxiliary source of current supply shall be permitted to be a separate service from the vault. A transfer switch shall not be required.

(H) Approved Generator. Where the normal source of current supply is an approved utility company service, the auxiliary source of current supply shall be permitted to be an on-site generator installed in accordance with Article 701.

(I) Inverter System. Where the normal source of current supply is an approved utility company service, the auxiliary source of current supply shall be permitted to be an approved on-site inverter complying with the following:

(1) The inverter system shall be listed for emergency system use and have battery capacity to power the entire emergency lighting and exit sign system as follows:

- (a) In high rise buildings as required by Section 700.30 for a period of four hours
- (b) In places of assembly with an occupancy greater than 1,000 persons for a period of four hours
- (c) In all other occupancies for a period of ninety minutes.

(2) The inverter system shall be tested at full load for the rated time at least once per year.

(3) This annual test shall be witnessed by the authority having jurisdiction, and the required inspection fee for this test shall be paid.

Informational Note: Note that utility supplied auxiliary sources as listed in 700.33(A) through (G) above shall not solely satisfy the emergency illumination requirements of this article. See 700.6(C).

700.43 Approved Unit Battery Equipment.

(A) Approved Unit Battery Equipment. Approved unit battery equipment shall be permitted as the auxiliary source of current supply as follows:

(1) The required emergency lighting and exit lighting systems in any building or space where a System III is required

(2) The required emergency lighting and exit lighting systems in any building where a System II is required, other than a high rise building which shall comply with 700.30, provided that:

- (a) There is sufficient general and, or emergency illumination that is on at all times the building is occupied
- (b) The installation, control and maintenance of the emergency system complies with Part V of this article

(3) The required emergency lighting and exit lighting systems in existing high rise residential buildings not over 91 m (300 ft) in height, provided that:

- (a) There is sufficient general and, or emergency illumination that is on at all times the building is occupied
- (b) The installation, control and maintenance of the emergency system complies with Part V of this article.

(4) The final reserve source for places of assembly in existing buildings where a System I is required.

Informational Note: In all new and existing high rise buildings containing residential type units 91 m (300 ft) in height and greater, a diesel generator is the only acceptable method of supply to the required emergency illumination and exit sign system unless allowed by 700.30(C)(Exception No. 2).

Unit battery equipment shall comply with 700.66(C).

Informational Note: Nothing in this Code prohibits battery backed up exit signs as long as they

are installed in conformance with the above requirements and conform to relevant sections of the *Building Code*.

700.44 Battery Systems as Back-up Source for Exit Signs. Where no generator or battery inverter system is used, the back-up source of current supply for exit signs shall be approved unit battery exit signs conforming to Section 700.66 and Sections 13-160-740 through 13-160-800 of the *Chicago Building Code*.

Part IV. Final Reserve Source of Current Supply

700.50 Approved Final Reserve Source of Current Supply. In all cases the final reserve source of current supply shall be one of the following and shall be able to operate at full load for a minimum of 4 hours:

- (1) An approved on-site generator in conformance with Article 701
- (2) An approved battery system
- (3) An approved inverter system

Part V. Installation and Control of Systems

700.59 Installation and Control of Systems. The following shall be required for installation and control of systems:

- (1) Buildings that are closed and not occupied for a portion of the day shall be permitted to have the emergency lighting and exit lighting systems controlled by a manually operable non-locking type switch(es) located only in the main lobby or lobbies, entrances, or entrance stairways.
- (2) Where there is more than one main lobby, entrance or entrance stairway switches which turn all exit and emergency lights "ON" shall be permitted to be installed in each location. A switch to turn these lights "OFF" shall be permitted to be installed in only one of these locations.
- (3) In high rise buildings with a fire command panel, the switch referred to in this section shall be located in or adjacent to the fire command panel.
- (4) In buildings without a fire command panel, the switch(es) shall be identified and the "OFF" switch(es) shall be installed behind locked break glass covers.

700.60 Switches Allowed. Only the following switches shall be permitted in the emergency lighting and exit lighting systems:

- (1) The service switch
- (2) Feeder switch(es) (if required)
- (3) The required transfer switch(es)
- (4) The lobby control switch(es)

700.61 Dimmer and Relay Systems. A dimmer or relay system containing more than one dimmer or relay and listed for use in emergency systems shall be permitted to be used as a control device for energizing emergency lighting circuits. Upon failure of normal power, the dimmer or relay system shall be permitted to selectively energize only those branch circuits required to provide minimum emergency illumination. All branch circuits supplied by the dimmer or relay system cabinet shall comply with the wiring methods of Article 700.

700.62 Circuit Breakers and Fuses.

(A) Circuit Breakers. Circuit breakers are switching devices and shall be permitted to be used for service, feeder, or branch circuit overcurrent protection only under the following conditions:

- (1) Standard single pole circuit breakers, prominently identified as required by 700.63, used for branch circuit protection where a branch circuit panel is installed in an electrical closet or switchboard room accessible only to qualified persons
- (2) Single pole, key-operated circuit breakers used for emergency branch circuit protection in any panel location
- (3) Standard circuit breakers may be used where the emergency branch circuit distribution panel feeds only three-phase loads which are required to be on the emergency system
- (4) Standard circuit breakers with approved lock-on devices shall be permitted for branch circuits where supplying emergency illumination and exit signs and unit battery equipment complying with 700.66

(B) Fuses. Standard fused switch equipment shall be permitted to be used for feeder overcurrent protection when installed in locked room accessible only to qualified persons and identified in accordance with 700.63.

700.63 Separate Wiring Systems.

(A) Identification. All boxes and enclosures (including transfer switches, generators, transformers and power panels) for emergency circuits shall be permanently marked so they will be readily identified as a component of an emergency circuit or system. The legends for all branch circuit and feeder distribution panels shall be marked to identify the loads they serve.

(B) Wiring Separation. Emergency lighting and exit lighting system feeders and branch circuits, shall be completely separate and independent wiring systems from all other electrical systems starting from the source of current supply to the last lighting outlet on the systems.

Emergency illumination and exit sign equipment branch circuit conductors shall be permitted to occupy the same raceway and share the same branch circuit. These branch circuits shall not be part of multiwire branch circuits.

Emergency unit battery equipment as allowed in 700.43 shall be permitted to share general lighting branch circuits when in conformance with 700.66. Emergency battery unit wiring shall conform to Section 700.66(C).

(C) Wiring Design and Location. Emergency wiring circuits shall be designed and located to minimize the hazards that might cause failure due to flooding, fire, icing, vandalism, and other adverse conditions.

No apparatus or lighting outlets other than those specified shall be permitted to be connected to exit and emergency lighting systems. Branch circuits shall be allowed a maximum of 15 emergency lighting outlets per branch circuit.

(D) Fire Protection. In new buildings and buildings undergoing 60% or greater remodeling of interior spaces or the electrical system, the emergency lighting and exit lighting systems shall meet the following additional requirements in (D)(1) through (D)(3) in the following occupancies:

- (1) Assembly occupancies for not less than 1000 persons
- (2) High rise buildings
- (3) Health care occupancies where persons are not capable of self- preservation
- (4) Educational occupancies with more than 300 occupants

(1) Feeder-Circuit Wiring. Feeder-circuit wiring shall meet one of the following conditions:

- (1) Be installed in spaces or areas that are fully protected by an approved automatic fire suppression system
- (2) Be a listed electrical circuit protective system with a minimum 2-hour fire rating

Informational Note No. 1: Electrical circuit protective systems could include but not be limited to thermal barriers or a protective shaft and are tested to UL 1724 Fire Tests for Electrical Circuit Protection Systems.

Informational Note No. 2: The listing organization provides information for electrical circuit protective systems on proper installation requirements to maintain the fire rating.

- (3) Be a listed fire-resistive cable system installed in a metal raceway and supported according to listing requirements

Informational Note No. 1: Fire-resistive cables are tested to ANSI/UL 2196, Tests for Fire-Resistive Cables.

Informational Note No. 2: The listing organization provides information for electrical circuit protective systems on proper installation requirements to maintain the fire rating.

- (4) Be protected by a listed fire-rated assembly that has a minimum fire rating of 2 hours and contains only emergency wiring circuits

- (5) Be encased in a minimum of 50 mm (2 in.) of concrete

(6) Be a cable installed in a metallic raceway listed to maintain circuit integrity for a minimum of 2 hours when installed in accordance with the listing requirements.

(2) Feeder-Circuit Equipment. Equipment for feeder circuits (including transfer switches, transformers, and panel-boards) shall be located either in spaces fully protected by approved automatic fire suppression systems (including sprinklers, carbon dioxide systems) or in spaces with a 2-hour fire resistance rating.

(3) Generator Control Wiring. Control conductors installed between the transfer equipment and the emergency generator shall be kept entirely independent of all other wiring and shall meet the conditions of 700.63(D)(1).

700.64 Other Loads. The following loads shall be permitted to be connected to separate emergency branch circuits.

- (1) The loads required to be connected to the high rise emergency system

Informational Note: See relevant sections of the *Chicago Building Code* related to high rise emergency requirements.

(2) Emergency voice communication systems that are specifically designed to be used for issuing instructions during emergency conditions

(3) The loads required for hospital emergency systems.

Informational Note: See Article 517.

(4) Required fire alarm systems.

Informational Note: See Article 760.

(5) Loads required or allowed elsewhere in this *Code* to be on the emergency system.

700.65 Existing Multifamily Dwelling Unit Buildings. For existing multifamily dwelling unit buildings:

(1) Service conductors having an ampacity of 40 amperes shall be permitted for single-phase, three-wire services that serve no more than four 15-ampere branch circuits.

(2) Where the building is 4 stories or less in height and is served directly by vertical front and rear stairwells, all existing stairwell lighting outlets shall be permitted to be supplied from the emergency service. Corridor emergency lighting outlets shall be in addition to the general illumination.

(3) Other loads such as laundry outlets, heating plants, sump pumps, garage and basement lighting shall not be permitted to be supplied from the emergency service.

(4) Emergency lights shall be permitted to be controlled by photocell switches. Time clocks shall not be permitted.

(5) High rise multifamily dwelling unit buildings shall be in conformance with 700.30.

700.66 Approved Unit Battery Equipment and Battery Systems. The following shall apply to batteries and battery systems for emergency systems:

(A) Dry Cell Batteries. Dry cell batteries shall not be permitted on any emergency lighting system.

(B) Battery and Battery Inverter Systems. Battery and battery inverter systems, regardless of voltage, shall be listed for emergency lighting use.

(C) Unit Battery Equipment.

(1) Listing and Labeled. All unit batteries shall be listed and labeled as emergency luminaire equipment. Individual unit equipment for required standby emergency illumination shall consist of the following:

(a) A rechargeable battery

(b) A battery charging means

(c) Provisions for one or more lamps

(d) A relaying device arranged to automatically energize the lamps upon failure of the supply to the unit equipment

- (e) Batteries of suitable rating and capacity to supply and maintain not less than 87½ percent of the nominal battery voltage for the total lamp load associated with the unit for a period of at least 90 minutes
- (f) Acid or alkali storage batteries designed and constructed to meet the requirements of emergency service.

(2) Provisions. The unit equipment shall be provided with:

- (a) A test switch for checking the operating conditions of the unit.
- (b) A pilot light to indicate when the battery charger is functioning, when tied to the normal source. Functioning of the battery charger is intended to mean the presence of charging voltage.
- (c) The pilot light shall not be marked "READY" to indicate power available.

(3) Enclosure. The unit battery and lamp housing shall be made of metal. In wet or corrosive locations housings that are listed for emergency use and suitable for the environment shall be permitted to be made of other materials.

Exception: Decorative plastic enclosures over metal housings shall be permitted.

(4) Wiring. The wiring shall comply with the following:

- (a) Unit equipment shall be permanently fixed in place and supplied with an approved metallic raceway.
- (b) Flexible cord and plug connections shall not be permitted.
- (c) The branch circuit feeding the unit equipment shall be the same branch circuit as that serving the normal illumination, or (emergency illumination where present) in the area and connected ahead of any local switches.
- (d) The branch-circuit device shall be a type S plug fuse, a circuit breaker of the key operated type, or shall be provided with a locking device to prevent inadvertent opening of the circuit and shall comply with 700.63.
- (e) The panel directory shall be prominently marked to identify the circuits that supply the unit batteries.
- (f) Where there is a separate and uninterrupted area supplied by a minimum of 3 normal lighting circuits, a separate branch circuit for unit batteries shall be permitted, provided the circuit originates from the same panelboard as that of the normal lighting circuits and is either a type S plug fuse, a circuit breaker of the key operated type, or a circuit breaker provided with a lock on feature.
- (g) No more than three lamps shall be permitted to be supplied from one-unit battery.
- (h) When a remote lamp is connected to a unit battery, the wiring shall be in an approved metallic raceway and shall be independent of all other wiring and equipment. The wiring shall be limited to 4.57 m (15 ft) and shall not enter the same raceway, box, or cabinet with other wiring.

Exception: Wiring in a length greater than 4.57 m (15 ft) shall be permitted where it can be shown that by increased wire size, the voltage drop from the battery to the lamp will still allow the lamp to operate at normal brilliance.

(5) Location. Luminaires shall be so located as to provide the illumination required in 700.6 upon failure of the normal lighting service; these lights shall not be required to be "ON" until failure occurs. In general, one luminaire shall be provided for each 214 m² (2,300 ft²) of open

floor area. Where this number of luminaires does not provide illumination of all areas leading to points of egress, additional luminaires shall be installed.

(6) Lamp Output. Each lamp shall provide a minimum of 300 lumen output. Single lamps connected to unit batteries that provide the required illumination and are maintained in accordance with subsection (7) below shall be permitted in areas less than 214 m² (2300 ft²).

(7) Maintenance. Unit batteries shall be maintained by qualified maintenance personnel and the following records shall be maintained:

- (a) The manufacturer shall supply with each unit battery a complete set of instructions for the operation and maintenance of the equipment.
- (b) The date of original installation and of subsequent battery replacements shall be posted conspicuously on the battery container.
- (c) Each unit shall be tested annually.
- (d) There shall be a water level indicator where applicable and the water shall be checked monthly.
- (e) A readily available log of these inspections shall be maintained on a card attached to the unit battery. The card shall contain the name and address of the responsible maintenance personnel that performed the testing required in (c) and (d) of this subsection.

700.67 Generators. On-site generators are recognized as an approved source of current supply for Emergency Systems I, II, and III. On-site generator(s) used as a current supply for emergency systems shall comply with the requirements of Article 701.

700.68 Tests and Maintenance.

(A) Conduct or Witness Test. The authority having jurisdiction shall conduct or witness a test of the complete system upon installation and periodically afterward.

(B) Tested Periodically. Systems shall be tested annually or more frequently on a schedule acceptable to the authority having jurisdiction to ensure the systems are maintained in proper operating condition.

(C) Maintenance. Emergency system equipment shall be maintained in accordance with manufacturer instructions and industry standards. These instructions shall be kept on-site and made available to the authority having jurisdiction upon request.

(D) Written Record. A written record shall be kept on such tests and maintenance, maintained on the premises for not less than 10 years, and made available to the authority having jurisdiction upon request.

(E) Testing Under Load. Means for testing all emergency lighting and power systems during maximum anticipated load conditions shall be provided.

Informational Note 1: For information on testing and maintenance of emergency power supply systems (EPSSs), see NFPA 110-2013, Standard for Emergency and Standby Power Systems.

Informational Note 2: See 700.66(C)(7).

700.69 Special Provisions for Special Circumstances. The provision of 700.1 thru 700.67 are not intended to limit or inhibit the engineering ingenuity of engineers or contractors in laying out such installations.

Where it can be demonstrated that an alternate design of emergency systems will provide an equivalent or greater level of safety and reliability than that intended by Article 700, the authority having jurisdiction is empowered to grant special permission for alternate emergency systems in lieu of the specifically required systems. The final determination of equivalency, in all cases, shall be made by the authority having jurisdiction.”

14E-7-701 Legally Required Standby Generator Systems

The provisions of Article 701 of NFPA 70 are adopted by reference with the following modifications:

Revise subsection 701.3(B), (C) and (D) to read:

(B) Tested Annually. Systems shall be tested annually or more frequently on a schedule and in a manner acceptable to the authority having jurisdiction to ensure the systems are maintained in proper operating condition.

(C) Maintenance. Legally required standby system equipment shall be maintained in accordance with manufacturer instructions and industry standards. These instructions shall be kept on-site and made available to the authority having jurisdiction upon request.

(D) Written Record. A written record shall be kept on such tests and maintenance, maintained on the premises for not less than 10 years, and made available to the authority having jurisdiction upon request.”

Insert new section 701.8 to read:

“Signal Annunciator. A storage-battery powered remote annunciator shall be installed outside of the generator room in a location readily observed by operating personnel at a regular work station. In addition, unless a regular work station is continuously manned, an appropriately labeled audible and visual signal shall be installed at a manned location. The remote annunciator panel shall include a voltage meter and a lamp test function and shall be permitted to have an alarm silencing switch and pilot light to indicate alarm silenced. In addition to the signals described in 701.6 (A), (B), (C) and (D) there also shall be a signal to indicate when the generator is not in the automatic position.”

Insert new section 701.9 to read:

“Plans Required. Complete and detailed plans and specifications of all emergency generators shall be submitted to the authority having jurisdiction for review before any construction work is started. These plans shall include the following:

(1) A single line drawing of the complete emergency and/or essential electrical system. The drawing shall include all components of the system(s) including utility source(s), generator(s), transfer switch(es), feeder distribution panel(s), and branch circuit

panelboard(s).

(2) A floor or site plan of the engine generator room or location which shows to scale the location of all equipment and the working space provided.”

Insert new Part V to read:

“Other Requirements

701.29 Generator auxiliary equipment.

Auxiliary electrical equipment essential to the running of the generator shall be connected to one or more of the generator disconnect switches. This disconnect switch(es) shall feed no other loads. Essential generator auxiliary equipment includes, but is not limited to:

- (a) Cooling fan motor for a remote radiator
- (b) Auxiliary water pump
- (c) Storage tank fuel pump
- (d) Normally off, unswitched emergency lights at the generator, control panel, main distribution and service switchboard locations
- (e) Cool-down timer

701.30 Cool-down timer(s).

A cool-down timer(s) shall be installed so that in every case when generator operation is initiated and after the normal source of current supply is restored, the generator shall run without load for time equal to, or greater than, the generator manufacturers recommendations.

701.31 Isolated wiring.

The conduit and wiring of emergency systems shall be completely separate from all other wiring from the source to the load in accordance with Article 700. The wiring of emergency systems shall not occupy common raceways, wireways, junction boxes, or header boxes with other conductors.

701.32 Identification.

All elements of the emergency system such as, transfer switches, distribution centers, transformers and service switches shall be plainly and visibly identified by appropriate nameplates as being part of the emergency system. The legends for all branch circuit and feeder distribution panels shall be filled out identifying the circuits and the loads they serve.

A copy of the one-line wiring diagram of the entire emergency system describing its basic mode of operation as described in 700.3(c) shall be displayed at the service switch location, the generator location, and the transfer switch locations for the reference of operating and maintenance personnel.

701.33 Initial test.

A 4-hour full load test based on the rating of the generator shall be performed when a generator(s) is first installed. This test shall be witnessed by the authority having jurisdiction, and the required inspection fee for this test shall be paid.

701.34 Weekly tests.

Each generator installation shall be tested weekly under load conditions. A log shall be maintained of these tests. The log shall record the following:

- (a) Date and time of day
- (b) Voltage and ampere reading (load)
- (c) Running time reading at the start of test
- (d) Running time reading at the end of the test
- (e) Any abnormalities discovered, and other significant data

For testing purposes, a transfer switch(es) shall be provided with a "time-delay on return to normal" which will keep the engine generator running for a minimum of 20 minutes under load once a transfer to the generator has occurred.

701.35 Annual test.

The generator shall be tested annually for a period of at least one hour under heavy load. This test shall be witnessed by the authority having jurisdiction, and the required inspection fee for this test shall be paid.

701.36 Supervision.

At the time of installation of the generator, the owner or manager of the building in which the generator is to be installed shall designate a person who will be responsible for the proper operation and maintenance of the generator(s). This person shall be known as the supervisor of the generator(s). The supervisor of the generator(s) shall be competent to perform the normal operational and maintenance functions required.

When the weekly tests are not being performed on the generator, it is the supervisor of the generator(s) responsibility to notify the authority having jurisdiction in order that corrective action can be taken.

701.37 Two or more generators.

Installations of emergency systems which contain two or more generators shall require special permission."

14E-7-702 Optional Standby Systems

The provisions of Article 702 of NFPA 70 are adopted by reference without modification.

14E-7-705 Interconnected Electric Power Production Sources

The provisions of Article 705 of NFPA 70 are adopted by reference without modification.

14E-7-706 Energy Storage Systems

The provisions of Article 706 of NFPA 70 are adopted by reference without modification.

14E-7-708 Critical Operations Power Systems (COPS)

The provisions of Article 708 of NFPA 70 are adopted by reference without modification.

14E-7-710 Stand-Alone System

The provisions of Article 710 of NFPA 70 are adopted by reference without modification.

14E-7-712 Direct Current Microgrids

The provisions of Article 712 of NFPA 70 are adopted by reference without modification.

14E-7-720 Circuits and Equipment Operating at Less Than 50 Volts

The provisions of Article 720 of NFPA 70 are adopted by reference without modification.

14E-7-725 Class 1, Class 2, and Class 3 Remote-Control, Signaling, and Power-Limited Circuits

The provisions of Article 725 of NFPA 70 are adopted with the following modifications:

1. Revise section 725.3 to read:

725.3 Other Articles. Circuits and equipment shall comply with the articles or sections listed in 725.3(A) through (N). Only those sections of Article 300 referenced in this article shall apply to Class 1, Class 2, and Class 3 circuits.

(A) **Number and Size of Conductors in Raceway.** Installations shall comply with 300.17.

(B) **Spread of Fire or Products of Combustion.** Installation of Class 1, Class 2, and Class 3 circuits shall comply with 300.21.

(C) **Ducts, Plenums, and Other Air-Handling Spaces.** Class 1, Class 2, and Class 3 circuits installed in ducts, plenums, or other space used for environmental air shall comply with 300.22.

(D) **Hazardous (Classified) Locations.** Articles 500 through 516 and Article 517, Part IV, where installed in hazardous (classified) locations.

(E) **Cable Trays.** Article 392, where installed in cable tray.

(F) **Motor Control Circuits.** Article 430, Part VI, where tapped from the load side of the motor branch-circuit protective device(s) as specified in 430.72(A).

(G) **Instrumentation Tray Cable.** See Article 727.

(H) **Raceways Exposed to Different Temperatures.** Installations shall comply with 300.7(A).

(I) Vertical Support for Fire-Rated Cables and Conductors. Vertical installations of circuit integrity (CI) cables and conductors installed in a raceway or conductors and cables of electrical circuit protective systems shall be installed in accordance with 300.19.

(J) Bushing. A bushing shall be installed where cables emerge from raceway used for mechanical support or protection in accordance with 300.15(C).

(K) Installation of Conductors with Other Systems. Installations shall comply with 300.8.

(L) Corrosive, Damp, or Wet Locations. Class 2 and Class 3 cables installed in corrosive, damp, or wet locations shall comply with the applicable requirements in 110.11, 300.5(B), 300.6, 300.9, and 310.10(G).

(M) Cable Routing Assemblies. Class 2, Class 3, and Type PLTC cables shall be permitted to be installed in riser cable routing assemblies, and general-purpose cable routing assemblies selected in accordance with Table 800.154(C), listed in accordance with the provisions of 800.182, and installed in accordance with 800.110(C) and 800.113.

(N) Communications Raceways. Class 2, Class 3, and Type PLTC cables shall be permitted to be installed in plenum communications raceways, riser communications raceways, and general-purpose communications raceways selected in accordance with the provisions of Table 800.154(b), listed in accordance with 800.182, and installed in accordance with 800.113.

Revise subsection 725.135(B) and (C) to read:

“(B) Ducts Specifically Fabricated for Environmental Air. Wires and cables installed in ducts specifically fabricated for environmental air shall be installed in accordance with 300.22(B).

(C) Other Spaces Used for Environmental Air (Plenums). Wires and cables installed in other spaces used for environmental air (plenums) shall be installed in accordance with 300.22(C).”

Revise the first paragraph of section 725.144 to read:

“The requirements of 725.144(A) and (B) shall apply to Class 2 and Class 3 circuits that transmit power and data to a powered device. The requirements of Parts I and III of Article 725, 300.11, and 300.22 shall apply to Class 2 and Class 3 circuits that transmit power and data. The conductors that carry power for the data circuits shall be copper. The current in the power circuit shall not exceed the current limitation of the connectors.”

Revise Table 725.154 to read:

Table 725.154 Applications of Listed Class 2, Class 3, CMUC, and PLTC Cables in Buildings

Applications		Wire and Cable Type					
		CL2P & CL3P	CL2R & CL3R	CL2 & CL3	CL2X & CL3X	CMUC	PLTC
In fabricated ducts as described in 300.22(B)	In fabricated ducts	N	N	N	N	N	N
	In metal raceway that complies with 300.22(B)	Y*	Y*	Y*	Y*	N	Y*
In other spaces used for environmental air as described in 300.22(C)	In other spaces used for environmental air	N	N	N	N	N	N
	In metal raceway that complies with 300.22(C)	Y*	Y*	Y*	Y*	N	Y*
In risers	In vertical runs	Y*	Y*	N	N	N	N
	In metal raceways	Y*	Y*	Y*	Y*	N	Y*
	In fireproof shafts	Y*	Y*	Y*	Y*	N	Y*
	In plenum communications raceways	Y*	Y*	N	N	N	N
	In riser communications raceways	Y*	Y*	N	N	N	N
	In riser cable routing assemblies	Y*	Y*	N	N	N	N
	In one- and two-family dwellings	Y*	Y*	Y*	Y*	N	Y*
Within buildings in other than air-handling spaces and risers	General	Y*	Y*	Y*	Y*	N	Y*
	In one- and two-family dwellings	Y*	Y*	Y*	Y*	Y*	Y*
	In multifamily dwellings	Y*	Y*	Y*	Y*	Y*	Y*
	In non-concealed spaces	Y*	Y*	Y*	Y*	Y*	Y*
	Supported by cable trays	Y*	Y*	Y*	N	N	Y*
	Under carpet	N	N	N	N	Y*	N
	In cross-connect arrays	Y*	Y*	Y*	N	N	Y*
	In any raceway recognized in Chapter 3	Y*	Y*	Y*	Y*	N	Y*
	In plenum communications raceways	Y*	Y*	Y*	N	N	Y*
	In riser communications raceways	Y*	Y*	Y*	N	N	Y*
	In riser cable routing assemblies	Y*	Y*	Y*	N	N	Y*
In general-purpose	Y*	Y*	Y*	N	N	Y*	

	communications raceways						
	In general-purpose cable routing assemblies	Y*	Y*	Y*	N	N	Y*

Note: "N" indicates that the cable type shall not be permitted to be installed in the application. "Y" indicates that the cable type shall be permitted to be installed in the application, subject to the limitations described in 725.130 through 725.143

14E-7-727 Instrumentation Tray Cable: Type ITC

The provisions of Article 727 of NFPA 70 are adopted by reference without modification.

14E-7-750 Energy Management Systems

The provisions of Article 750 of NFPA 70 are adopted by reference without modification.

14E-7-760 Fire Alarm Systems

The provisions of Article 760 of NFPA 70 are adopted with the following modifications:

1. Revise the first paragraph of section 760.3 to read:

"Circuits and equipment shall comply with 760.3(A) through (K). Only those sections of Article 300 referenced in this article shall apply to fire alarm systems."

Delete both exceptions to subsection 760.3(B).

Delete subsections 760.3(L) and (M).

Revise subsections 760.53(B)(1) and (2) to read:

(1) Ducts Specifically Fabricated for Environmental Air. Cables installed in ducts, specifically fabricated for environmental air shall be installed in accordance 300.22(B).

(2) Other Spaces Used for Environmental Air (Plenums). Cables installed in other spaces used for environmental air shall be installed in accordance with 300.22(C)."

Revise section 760.135 to read:

"Installation of PLFA Cables in Buildings. Installation of power-limited fire alarm cables in buildings shall comply with 760.135(A) through (J).

(A) Listing. PLFA cables installed in buildings shall be listed.

(B) Ducts Specifically Fabricated for Environmental Air. Wires and cables installed in ducts specifically fabricated for environmental air shall be installed in accordance with 300.22(B).

(C) Other Spaces Used for Environmental Air (Plenums). Cables installed in other spaces used for environmental air shall be installed in accordance with 300.22(C).

(D) Risers – Cables in Vertical Runs. The following cables shall be permitted in vertical runs penetrating one or more floors and in vertical runs in a shaft.

(1) Types FPLP and FPLR cables

(2) Types FPLP and FPLR cables installed in the following:

- a. Plenum communications raceways
- b. Riser communications raceways
- c. Riser cable routing assemblies

Informational Note: See 300.21 for firestop requirements for floor penetrations.

(E) Risers – Cables in Metal Raceways. The following cables shall be permitted in metal raceways in a riser having firestops at each floor:

(1) Types FPLP, FPLR, and FPL cables

(2) Types FPLP, FPLR, and FPL cables installed in:

- a. Plenum communications raceways
- b. Riser communications raceways
- c. General-purpose communication raceways

Informational Note: See 300.21 for firestop requirements for floor penetrations.

(F) Risers – Cables in Fireproof Shafts. The following cables shall be permitted to be installed in fireproof riser shafts having firestops at each floor:

(1) Types FPLP, FPLR, and FPL cables

(2) Types FPLP, FPLR, and FPL cables installed in:

- a. Plenum communications raceways
- b. Riser communications raceways
- c. Riser cable routing assemblies
- d. General-purpose communication raceways
- e. General-purpose cable routing assemblies

Informational Note: See 300.21 for firestop requirements for floor penetrations.

(G) Risers – One- and Two-Family Dwellings. The following cables shall be permitted in one- and two-family dwellings:

(1) Types FPLP, FPLR, and FPL cables

(2) Types FPLP, FPLR, and FPL cables installed in:

- a. Plenum communications raceways
- b. Riser communications raceways
- c. Riser cable routing assemblies
- d. General-purpose communication raceways

e. General-purpose cable routing assemblies

(H) Other Building Locations. The following cables shall be permitted to be installed in building locations other than the locations covered in 770.113(B) through (H):

(1) Types FPLP, FPLR, and FPL cables

(2) Types FPLP, FPLR, and FPL cables installed in:

- a. Plenum communications raceway
- b. Riser communications raceway
- c. Riser cable routing assemblies
- d. General-purpose communication raceways
- e. General-purpose cable routing assemblies

(3) Types FPLP, FPLR, and FPL cables installed in a raceway of a type allowed in Chapter 3.

(I) Nonconcealed Spaces. Cables specified in Chapter 3 and meeting the requirements of 760.179(A) and (B) shall be permitted to be installed in nonconcealed spaces where the exposed length of cable does not exceed 3 m (10 ft).

(J) Portable Fire Alarm System. A portable fire alarm system provided to protect a stage or set when not in use shall be permitted to use wiring methods in accordance with 530.12.”

Revise Table 760.154 to read:

“Applications of Listed PLFA Cables in Buildings

		Cable Type		
		FPLP & FPLP-CI	FPLR & FPLR-CI	FPL & FPL-CI
In fabricated ducts as described in 300.22(B)	In fabricated ducts	N	N	N
	In metal raceway that complies with 300.22(B)	Y*	Y*	Y*
In other spaces used for environmental air as described in 300.22(C)	In other spaces used for environmental air	N	N	N
	In metal raceway that complies with 300.22(C)	Y*	Y*	Y*
In risers	In vertical runs	Y*	Y*	N
	In metal raceways	Y*	Y*	Y*
	In fireproof shafts	Y*	Y*	Y*
	In plenum communications raceways	Y*	Y*	N
	In riser communications raceways	Y*	Y*	N

	In riser cable routing assemblies	Y*	Y*	N
	In one- and two-family dwellings	Y*	Y*	Y*
Within buildings in other than air-handling spaces and risers	General	Y*	Y*	Y*
	Supported by cable trays	Y*	Y*	Y*
	In any raceway recognized in Chapter 3	Y*	Y*	Y*
	In plenum communications raceways	Y*	Y*	Y*
	In riser communications raceways	Y*	Y*	Y*
	In riser cable routing assemblies	Y*	Y*	Y*
	In general-purpose communications raceways	Y*	Y*	Y*
	In general-purpose cable routing assemblies	Y*	Y*	Y*

Note: An "N" in the table indicates that the cable type is not permitted to be installed in the application. A "Y*" indicates that the cable is permitted to be installed in the application, subject to the limitations described in 770.110 and 770.113."

Insert new parts V and VI to read:

"Part V. Required Fire Alarm and Emergency Voice Communications Systems

760.180 General. The provisions of the *Chicago Building Code* governing the installation of required fire alarm systems and required emergency voice communication systems are hereby declared retrospective as well as prospective and shall apply to both existing buildings and buildings hereafter constructed, altered or converted.

Fire alarm systems and/or emergency voice communication systems are required by the *Chicago Building Code* for occupancies including but not limited to: schools, hospitals, day care centers, nursing homes, hotels and high rise buildings.

Informational Note: See Chapters 13-196 and 15-16 of the *Chicago Building Code* for requirements related to fire alarm systems and voice communication systems.

The workmanship, equipment and quality of installation shall conform to the requirements of Chapter 1 and Chapter 3 of this Title. The installation shall not be deemed complete before notification and inspection by the authority having jurisdiction.

760.181 Plans Required. Before work is begun on the installation or alteration of a required fire alarm or emergency voice communication system, complete and detailed plans and specifications of the proposed installation shall be submitted to the authority having jurisdiction. Only after approval by the authority having jurisdiction may work begin.

In addition to any other information required by the authority having jurisdiction, the plans shall include:

- a. Complete legible raceway diagrams showing all horizontal and lateral sections and two corresponding legible circuit diagrams
- b. Locations and details of the circuits of the control panel, alarm sending

stations, automatic detectors, alarm sounding devices, supervisory test switches, trouble sounding device, trouble sounding device test switch, pilot light and switch

c. Details of separate conductors in each raceway and the connections to their respective terminals

d. One-line wiring diagrams showing the service entrance conductors, equipment, and fire alarm supply source

e. Full load calculations for all initiating and signaling circuits

All diagrams shall be identified with the complete name, address, and class of occupancy such as school, hotel, hospital, etc.

760.182 Wiring Methods. The installation shall be performed such that the equipment, quality and workmanship conform to the requirements of Chapters 1 and 3 of this Title and as provided for in 760.182(A) through (G).

(A) Raceway. All conductors of the system shall be enclosed in an approved metal raceway system. This raceway system shall be dedicated and contain only the system conductors and any required interfaces.

Exception No. 1: Elevator traveling cables.

Exception No. 2: Type MI cable need not be installed in raceway.

(B) Raceway Fill. The fill of any part of the raceway shall not exceed 40% of the internal cross-sectional area of the raceway.

(C) Enclosures Fill. The fill of enclosures shall be as found in 314.16. Equipment protruding into the box or enclosure reduces the volume of the enclosure accordingly and shall be considered for fill purposes.

Exception: Listed system control equipment enclosures where all entering conductors terminate to the equipment within the enclosure.

(D) Marking. The box covers and all raceways for fire alarm systems shall be red in color.

(E) Protection. The raceway system shall be protected to minimize physical damage.

Where other sections of the *Chicago Building Code* require protection from fire, the raceway system shall follow one of the methods below:

(1) Run within a room or area(s) dedicated to the protection of electrical equipment, meeting the fire resistance construction rating of the specifying section of the *Chicago Building Code*.

(2) Protected by an electrical circuit protective system listed to meet UL 1724. The installation shall comply with any restrictions provided in the listing.

(3) Embedded in concrete with a minimum of 50 mm (2 in.) cover around the raceway. Any supports for the concrete shall be protected by equivalent encasement or other means to achieve the required fire resistance rating.

(F) System Control Equipment. Listed enclosures and back-boxes containing system

control equipment shall not have any conductors entering other than those conductors that terminate at the control equipment within these enclosures.

(G) Foreign Equipment Interfaces. Where equipment is installed to interface with outside equipment, foreign to the alarm system, and a monitoring relay is used for this purpose, the enclosure containing the monitoring relay shall be within 914 mm (3 ft) from the equipment being served.

Informational Note: An example of this equipment would be fan, electric lock or disconnect status monitoring.

(H) Voice Communication Circuits. The voice communication circuits and the fire detection circuits of a required fire alarm system may share the same conduit or approved raceway and use common control equipment and power supplies, subject to 760.182(B) and any fire protection requirement applicable to the voice communication risers.

Informational Note: See 13-76-080 for additional requirements applicable to high rise electrical systems.

760.183 Fire Alarm and Emergency Voice Communication Circuit Conductors.

Conductors shall have the properties of NPLFA circuit conductors as covered in Part II of Article 760. The minimum size shall be 16 AWG. 18 AWG shall be permitted when installed as part of a multiconductor cable.

Exception No. 1: Conductors which are listed and approved for the inter-connection of component parts for control equipment within a common enclosure or between close-nipped (6 in. or less) enclosures.

Exception No. 2: Conductors for coaxial cables, a minimum of 22 AWG for the center conductor.

Exception No. 3: Non-conductive fiber optic conductors.

Exception No. 4: Listed insulated continuous line-type heat detectors.

Exception No. 5: Listed elevator traveling cables.

Where equipment is listed to use a conductor size larger than the above minimums, the listed minimum shall be followed. All conductors making up a complete circuit shall be of the same size throughout that circuit.

All conductors and cables shall be installed in a manner consistent with their listing, following all specifications by the manufacturer related and requisite for such listing.

(A) Ampacity. 18 AWG and 16 AWG conductors shall only supply loads that do not exceed the ampacities given in Table 402.5. 14 AWG and larger conductors shall only supply loads that do not exceed the ampacities given in 310.15 as applicable.

(B) Voltage Drop. The maximum voltage drop at any point along an individual circuit shall not exceed 5% of the nominal voltage initially provided. The calculation for voltage

drop shall be made at the minimum operating voltage supplied by the control equipment when operating on secondary power using the maximum possible current draw for that circuit.

(C) Electrical Circuit Protection. To prevent possible system performance degradation or destruction due to electrical, electromagnetic, radio frequency, surge, transient or induction of or into any part of the system the following shall be performed:

- (1) Branch circuits feeding system power supplies shall be maintained a minimum of 50 mm (2 in.) from all other conductors within an enclosure.
- (2) Branch circuits feeding system power supplies shall be provided with listed transient voltage surge suppressors with a let-through voltage rating not greater than 400 volts.
- (3) AC circuits receiving power from system power supplies shall use twisted pair conductors, shielded conductors or both as necessary.
- (4) Any conductive circuit which runs outside the building envelope, shall be protected with listed isolated loop circuit protectors. The protectors shall be mounted within 1.52 m (5 ft) of the penetration to the outside with no equipment connected to the circuit between the protector and the penetration to the outside. The protector shall be suitably grounded.
- (5) Any circuit for which the system is listed as using a twisted pair, shield or both shall provide these conductors in accordance with the manufacturer's instructions.

(D) Terminations. All conductors shall be securely connected to their respective terminations by one of the following means:

- (1) Wrapping a single solid or bunch-tinned conductor $\frac{7}{8}$ turn around a screw terminal.
- (2) Placing a single conductor under a cup washer at a screw terminal.
- (3) Under a notched clamping plate for the termination of two separate solid or bunch-tinned conductors of the same gauge size.
- (4) Inside a pressure terminal where pressure is provided by a set screw to a single conductor.

Exception No. 1: Conductors which are part of an assembly provided by the manufacturer with retained plug connectors used within an enclosure or close-nipped (6 in.) enclosures.

Exception No. 2: Non-conductive fiber optic conductors.

(E) Splices. All conductors shall be installed continuous from the control equipment to all field equipment terminations without any splices, taps or intermediate terminations until reaching the end of the circuit.

Exception No. 1: Connections to elevator traveling cables using a suitable listed fully insulated terminal block meeting the termination requirements of 760.183(D).

Exception No. 2: AC/DC circuits receiving power from system power supplies and supplying system equipment on multiple floors / zones shall use a suitable listed fully insulated power distribution block meeting the termination requirements of 760.183(D).

Exception No. 3: Where shielded conductors are connected to equipment which has no provision for shield drain wire termination a suitable listed fully insulated terminal block meeting the termination requirements of 760.183(D).

Exception No. 4: Connection to listed supervisory devices manufactured with built-in monitoring switches having conductor leads shall use a suitable listed fully insulated terminal block meeting the termination requirements of 760.183(D).

Exception No. 5: End-of-line devices which do not have separate terminals on equipment on which to terminate shall use a suitable listed fully insulated terminal block meeting the termination requirements of 760.183(D).

Exception No. 6: For existing systems with in place conductors where the system will be extended or altered, a suitable listed fully insulated terminal block meeting the termination requirements of 760.183(D) shall be used when:

- (1) Special permission has been granted*
- (2) There is no T-tapping or other wiring method that will impair the required supervision*
- (3) Drawings show the exact location of each junction box containing a splice*
- (4) Junction box containing such splices shall be located in a protected fire rated area as required in 760.182(E)*
- (5) Only one such box shall be permitted on a floor and shall be painted red and marked "FIRE ALARM SPLICE."*

760.184 Power Supply. The primary power supply to a required fire alarm system shall originate from an emergency system installed as required in Article 700.

Emergency branch circuits supplying the fire alarm system shall be grouped and permanently identified as "FIRE ALARM CIRCUIT."

Informational Note: Refer to NFPA 72 latest edition, Fire Alarm and Signaling Code, See 10.6.5.2.2 Circuit Identification and Accessibility regarding more labeling of fire alarm disconnecting means.

The secondary power supply capacity for a required fire alarm system shall not be less than as specified by the authority having jurisdiction for the type of occupancy served.

760.185 Location. The control equipment shall be located as near to the source of supply as is practicable. The control equipment shall be located within a room, dedicated to the protection of electrical equipment, of one-hour fire rated construction with one-hour rated and labeled doors and one-hour protected openings other than doors. No control equipment shall be located below grade.

760.187 Approval. The required fire alarm system and all equipment used in conjunction with the fire alarm system shall be of a type approved by authority having jurisdiction.

Part VI. Connection of a Required Fire Alarm System and Emergency Voice Communication System to an Off-Premise Monitoring System

760.208 General. Where the *Chicago Building Code* requires that a required fire alarm system or emergency voice communication system be connected to an off-premise monitoring service, the provisions of this Part and Part VII shall apply. Such connection shall be considered as a component of the required fire alarm system or emergency voice communication system and shall be incorporated in the plans and diagrams which are required by 760.181.

760.209 Type of Service. The off-premise monitoring service shall consist of either a municipal fire alarm box or a central station service. The type of service shall be as determined by the authority having jurisdiction.

760.210 Wiring Method.

(A) Municipal Fire Alarm Box. The conductors connecting the required fire alarm system to the municipal fire alarm box shall be run in metal conduit. Where the conductors run outside the building they shall be encased in galvanized rigid metal conduit or intermediate metal conduit from the penetration of the building envelope to the pedestal of the municipal fire alarm box. The conduit shall contain no conductors other than those necessary for operation of the municipal fire alarm box and conform to the following:

- (1) The minimum size conduit used shall be 2 in. When outside it shall be buried a minimum of 24 in. below surrounding grade. The conduit shall be continuous with no junction boxes from the control equipment to municipal fire alarm box shell.
- (2) Five 14 AWG or larger conductors shall be run. Each shall be of a different color. One shall be green, which shall be bonded to the enclosure of the control equipment inside the building and to the shell of the municipal box. Two of the remaining conductors shall be used for the fire alarm trip coil circuit. The two unused conductors will be spares.
- (3) All conductors run outside the building shall be protected by a listed isolated loop circuit protector. The protector shall be located in a junction box at the point of exit from the building.

(B) Central Station Service. The conductors connecting the required fire alarm system or emergency voice communication system to the central station service shall be run in metal conduit. The conduit shall contain no conductors other than those necessary for operation of the central station service and shall conform to the following:

- (1) The minimum size conduit shall be 1 in. and the conduit shall be continuous with no junction boxes from the control equipment to the central station service equipment.
- (2) Where required by 760.182, conductors between the control equipment monitored and the central station service equipment shall be protected for a minimum of one hour by a listed electrical circuit protective system. The installation shall comply with any restrictions provided in the listing.
- (3) Sufficient conductors shall be run to monitor all functions as required by the

authority having jurisdiction. All conductors shall be color coded. One provided conductor shall be green, which shall be bonded to the enclosure of the control equipment monitored and to the enclosure of the Central Station Service equipment. Two provided conductors shall be provided as spare conductors.

(4) All current carrying conductors run outside the building to the central station monitoring facility shall be protected by a listed secondary protector for communications circuits. The protector shall be located in a junction box at the point of exit from the building.

760.211 Power Supply. Any equipment requiring power for transmission of signals off premise shall obtain this power as specified in 760.184 from a separate circuit. Any equipment within the building which is required for the completion of transmission off-premise shall also meet these requirements. (i.e. fiber-optic network interface power supply).

760.212 Function of the Connection. This connection is required so that any fire alarm, and supervisory or trouble condition as required, inside of the building will automatically notify the off-premise monitoring service of said fire or condition. All supervisory and trouble conditions shall be annunciated in a manned location as directed by the Chicago Fire Department.

760.213 Supervision. The circuits necessary for these connections shall be electrically supervised for energy failure, open circuit fault, and ground fault.

Exception: Public utility communication circuits alter the interface to the transmission equipment need only be monitored for conditions which would prevent transmission.

760.214 Fire Drill Disconnect Switch. An approved type of switch may be provided which will disconnect the required fire alarm system from the municipal fire alarm box. This switch shall be mounted in the front of the control panel and shall be externally operable. It shall be of the key operated lock type or be a passcode protected keypad type. The disconnection shall cause a trouble condition in the system. The key shall be captive when the disconnect is in the "on" position. The passcode protected keypad shall not require any passcode or special knowledge to reactivate. The central station service equipment shall have no provision for a drill/disconnect feature.

760.215 Notification of Discontinuation of Service. Where a central station service discontinues service to a building, the central station service shall notify the Chicago Fire Department within 24 hours."

14E-7-770 Optical Fiber Cables and Raceways.

The provisions of Article 770 of NFPA 70 are adopted with the following modifications:

Revise section 770.110 to read:

"Raceways and Cable Routing Assemblies for Optical Fiber Cables.

(A) Types of Raceways. Optical fiber cables shall be permitted to be installed in any raceway that complies with either 770.110(A)(1) or (A)(2) and in cable routing

assemblies installed in compliance with 770.110(C).

(1) Raceways Recognized in Chapter 3. Optical fiber cables shall be permitted to be installed in any raceway included in Chapter 3. The raceways shall be installed in accordance with the requirements of Chapter 3.

(2) Communications Raceways. Optical fiber cables shall be permitted to be installed in listed plenum communications raceway, listed riser communications raceways, and listed general-purpose optical fiber raceway selected in accordance with the provisions of 770.113, 800.110 and 800.113.

(B) Raceway Fill for Optical Fiber Cables. Raceway fill for optical fibers cables shall comply with either 770.110(B)(1) or (B)(2).

(1) Without Electric Light or Power Conductors. Where optical fiber cables are installed in raceway without electric light or power conductors, the raceway fill requirements of Chapters 3 and 9 shall not apply.

(2) Nonconductive Optical Fiber Cables with Electric Light or Power Conductors. Where nonconductive optical fiber cables are installed with electric light or power conductors in a raceway, the raceway fill requirements of Chapters 3 and 9 shall apply.

(C) Cable Routing Assemblies. Optical fiber cables shall be permitted to be installed in riser cable routing assemblies, and general-purpose cable routing assemblies selected in accordance with the provisions of 800.113 and Table 880.154(c), listed in accordance with 800.182, and installed in accordance with 770.110(C)(1) and (C)(2).

(1) Horizontal Support. Cable routing assemblies shall be supported where run horizontally at intervals not to exceed 900 mm (3 ft), and at each end or joint, unless listed for other support intervals. In no case shall the distance between supports exceed 3 m (10 ft).

(2) Vertical Support. Vertical runs of cable routing assemblies shall be supported at intervals not exceeding 1.2 m (4 ft), unless listed for other support intervals, and shall not have more than one joint between supports.”

Revise section 770.113 to read:

“Installation of Optical Fiber Cables. Installation of optical fiber cables shall also comply with 770.13(A) through (J). Installation of raceways shall comply with 770.110.

(A) Listing. Optical fiber cables installed in buildings shall be listed in accordance with 770.110.

Exception: Optical fiber cables that comply with 770.48 shall not be required to be listed.

(B) Ducts Specifically Fabricated for Environmental Air. Wires and cables installed in ducts specifically fabricated for environmental air shall be installed in accordance with 300.22(B).

(C) Other Spaces Used for Environmental Air (Plenums). Wires and cables installed in other spaces used for environmental air (plenums) shall be installed in accordance with 300.22(C).

(D) Risers – Cables in Vertical Runs. The following cables shall be permitted in vertical runs penetrating one or more floors and in vertical runs in a shaft:

- (1) Types OFNP, OFCP, OFNR, and OFCR cables
- (2) Types OFNP, OFCP, OFNR, and cables installed in:
 - a. Plenum communications raceway
 - b. Riser communications raceway
 - c. Riser cable routing assemblies

(E) Risers - Cables in Metal Raceways. The following cables shall be permitted in metal raceways in a riser having firestops at each floor:

- (1) Types OFNP, OFCP, OFNR, OFCR, OFNG, OFCG, OFN, and OFC cables
- (2) Types OFNP, OFCP, OFNR, OFCR, OFNG, OFCG, OFN, and OFC cables installed in:
 - a. Plenum communications raceway
 - b. Riser communications raceway
 - c. General-purpose communication raceways

Informational Note: See 770.26 for firestop requirements for floor penetrations.

(F) Risers – Cables in Fireproof Shafts. The following cables shall be permitted to be installed in fireproof riser shafts having firestops at each floor:

- (1) Types OFNP, OFCP, OFNR, OFCR, OFNG, OFCG, OFN, and OFC cables
- (2) Types OFNP, OFCP, OFNR, OFCR, OFNG, OFCG, OFN, and OFC cables installed in:
 - a. Plenum communications raceway
 - b. Riser communications raceway
 - c. Riser cable routing assemblies
 - d. General-purpose communication raceways
 - e. General-purpose cable routing assemblies

Informational Note: See 770.26 for firestop requirements for floor penetrations.

(G) Risers - One- and Two-Family Dwellings. The following cables shall be permitted in one- and two-family dwellings:

- (1) Types OFNP, OFCP, OFNR, OFCR, OFNG, OFCG, OFN, and OFC cables
- (2) Types OFNP, OFCP, OFNR, OFCR, OFNG, OFCG, OFN, and OFC cables installed in:

- a. Plenum communications raceway
- b. Riser communications raceway
- c. Riser cable routing assemblies
- d. General-purpose communication raceways
- e. General-purpose cable routing assemblies

(H) Cable Trays. The following cables shall be permitted to be supported by cable trays:

- (1) Types OFNP, OFCP, OFNR, OFCR, OFNG, OFCG, OFN, and OFC cables
- (2) Types OFNP, OFCP, OFNR, OFCR, OFNG, OFCG, OFN, and OFC cables installed in:
 - a. Plenum communications raceway
 - b. Riser communications raceway
 - c. General-purpose communication raceways

(I) Distributing Frames and Cross-Connect Arrays. The following cables shall be permitted to be installed in distributing frames and cross-connect arrays:

- (1) Types OFNP, OFCP, OFNR, OFCR, OFNG, OFCG, OFN, and OFC cables
- (2) Types OFNP, OFCP, OFNR, OFCR, OFNG, OFCG, OFN, and OFC cables installed in:
 - a. Plenum communications raceway
 - b. Riser communications raceway
 - c. Riser cable routing assemblies
 - d. General-purpose communication raceways
 - e. General-purpose cable routing assemblies

(J) Other Building Locations. The following cables shall be permitted to be installed in building locations other than the locations covered in 770.113(B) through (I):

- (1) Types OFNP, OFCP, OFNR, OFCR, OFNG, OFCG, OFN, and OFC cables
- (2) Types OFNP, OFCP, OFNR, OFCR, OFNG, OFCG, OFN, and OFC cables installed in:
 - a. Plenum communications raceway
 - b. Riser communications raceway
 - c. Riser cable routing assemblies
 - d. General-purpose communication raceways
 - e. General-purpose cable routing assemblies
- (3) Types OFNP, OFCP, OFNR, OFCR, OFNG, OFCG, OFN, AND OFC cables installed in a raceway of a type recognized in Chapter 3."

Revise Table 770.154(a) to read:

“Applications of Listed Optical Fiber Cables in Buildings

		Cable Type		
		OFNP, OFCP	OFNR, OFCR	OFNG, OFCG, OFN, OFC
Applications				
In dusts specifically fabricated for environmental air as described in 300.22(B)	In fabricated ducts	N	N	N
	In metal raceway that complies with 300.22(B)	Y*	Y*	Y*
In other spaces used for environmental air (plenums) as described in 300.22(C)	In other spaces used for environmental air	N	N	N
	In metal raceway that complies with 300.22(C)	Y*	Y*	Y*
In risers	In vertical runs	Y*	Y*	N
	In metal raceways	Y*	Y*	Y*
	In fireproof shafts	Y*	Y*	Y*
	In plenum communications raceways	Y*	Y*	N
	In riser optical fiber and communications raceways	Y*	Y*	N
	In riser cable routing assemblies	Y*	Y*	N
	In one- and two-family dwellings	Y*	Y*	Y*
Within buildings in other than air-handling spaces and risers	General	Y*	Y*	Y*
	Supported by cable trays	Y*	Y*	Y*
	In distributing frames and cross connect arrays	Y*	Y*	Y*
	In any raceway recognized in Chapter 3	Y*	Y*	Y*
	In plenum communications raceways	Y*	Y*	Y*
	In riser communications raceways	Y*	Y*	Y*
	In riser cable routing assemblies	Y*	Y*	Y*
	In general-purpose communications raceways	Y*	Y*	Y*
	In general-purpose cable routing assemblies	Y*	Y*	Y*

Note: An “N” in the table indicates that the cable type is not permitted to be installed in the application. A “Y*” indicates that the cable is permitted to be installed in the application, subject to the limitations described in 770.110 and 770.113.

Informational Note No. 1: Part V of Article 770 covers installation methods within buildings. This table covers the applications of listed optical fiber cables and raceways, and cable routing assemblies in buildings. Optical fiber entrance cables that have not emerged from the rigid metal conduit or intermediate metal conduit are not considered to be in the building.

Informational Note No. 2: For information on the restrictions to the installation of optical fiber cables in fabricated ducts see 770.113(B)."

CHAPTER 14E-8 COMMUNICATIONS SYSTEMS

14E-8-800 Communications Circuits

The provisions of Article 800 of NFPA 70 are adopted by reference with the following modifications:

1. Revise subsection 800.110(A)(2) to read:

"Communications Raceways. Communications wires and cables shall be permitted to be installed in plenum communications raceways, riser communications raceways, and general-purpose communications raceways selected in accordance with Table 800.154(b), listed in accordance with 800.182, and installed in accordance with 800.113."

2. Revise subsections 800.113(B) through (L) to read:

(B) Ducts Specifically Fabricated for Environmental Air. Wires and cables installed in ducts specifically fabricated for environmental air shall be installed in accordance with 300.22(B).

(C) Other Spaces Used for Environmental Air (Plenums). Wires and cables installed in other spaces used for environmental air (plenums) shall be installed in accordance with 300.22(C).

(D) Risers — Cables, Raceways, and Cable Routing Assemblies in Vertical Runs. The following cables, raceways, and cable routing assemblies shall be permitted in vertical runs penetrating one or more floors and in vertical runs in a shaft:

- (1) Types CMP and CMR cables
- (2) Plenum and riser communications raceways
- (3) Riser cable routing assemblies
- (4) Types CMP and CMR cables installed in:
 - a. Plenum communications raceways
 - b. Riser communications raceways
 - c. Riser cable routing assemblies

Informational Note: See 800.26 for firestop requirements for floor penetrations.

(E) Risers — Cables and Innerducts in Metal Raceways. The following cables and innerducts shall be permitted in metal raceways in a riser having firestops at each floor:

- (1) Types CMP, CMR, CMG, CM, and CMX cables
- (2) Plenum, riser, and general-purpose communications raceways
- (3) Types CMP, CMR, CMG, CM, and CMX cables installed in:

- a. Plenum communications raceways (innerduct)
- b. Riser communications raceways (innerduct)
- c. General-purpose communications raceways (innerduct)

Informational Note: See 800.26 for firestop requirements for floor penetrations.

(F) Risers — Cables, Raceways, and Cable Routing Assemblies in Fireproof Shafts. The following cables, raceways, and cable routing assemblies shall be permitted to be installed in fire-proof riser shafts having firestops at each floor:

- (1) Types CMP, CMR, CMG, CM, and CMX cables
- (2) Plenum, riser, and general-purpose communications raceways
- (3) Riser, and general-purpose cable routing assemblies
- (4) Types CMP, CMR, CMG, and CM cables installed in:
 - a. Plenum, riser, and general-purpose communications raceways
 - b. Riser, and general-purpose cable routing assemblies

Informational Note: See 800.26 for firestop requirements for floor penetrations.

(G) Risers — One- and Two-Family Dwellings. The following cables, raceways, and cable routing assemblies shall be permitted in one- and two-family dwellings:

- (1) Types CMP, CMR, CMG, and CM cables
- (2) Type CMX cables less than 0.25 in. in diameter
- (3) Plenum, riser, and general-purpose communications raceways
- (4) Riser, and general-purpose cable routing assemblies
- (5) Types CMP, CMR, CMG, and CM cables installed in:
 - a. Plenum, riser, and general-purpose communications raceways
 - b. Riser, and general-purpose cable routing assemblies

(H) Cable Trays. The following wires, cables, and raceways shall be permitted to be supported by cable trays:

- (1) Types CMP, CMR, CMG, and CM cables
- (2) Plenum, riser, and general-purpose communications raceways
- (3) Communications wires and Types CMP, CR, CMG, and CM cables installed in:
 - a. Plenum communications raceways
 - b. Riser communications raceways
 - c. General-purpose communications raceways

(I) Distributing Frames and Cross-Connect Arrays. The following wires, cables, raceways, and cable routing assemblies shall be permitted to be installed in distributing frames and cross-connect arrays:

- (1) Types CMP, CMR, CMG, and CM cables and communications wires
- (2) Plenum, riser, and general-purpose communications raceways
- (3) Riser, and general-purpose cable routing assemblies
- (4) Communications wires and Types CMP, CMR, CMG, and CM cables installed in:

- a. Plenum communications raceways
- b. Riser communications raceways
- c. General-purpose communications raceways
- d. Riser cable routing assemblies
- e. General-purpose cable routing assemblies

(J) Other Building Locations. The following wires, cables, raceways, and cable routing assemblies shall be permitted to be installed in building locations other than the locations covered in 800.113(B) through (I):

- (1) Types CMP, CMR, CMG, and CM cables
- (2) A maximum of 3 m (10 ft) of exposed Type CMX in non-concealed spaces
- (3) Plenum, riser, and general-purpose communications raceways
- (4) Riser, and general-purpose cable routing assemblies
- (5) Communications wires and Types CMP, CMR, CMG, and CM cables installed in:

- a. Plenum communications raceways
- b. Riser communications raceways
- c. General-purpose communications raceways

(6) Types CMP, CMR, CMG, and CM cables installed in:

- a. Riser cable routing assemblies
- b. General-purpose cable routing assemblies

(7) Communications wires and Types CMP, CMR, CMG, CM, and CMX cables installed in raceways recognized in Chapter 3

(8) Type CMUC under-carpet communications wires and cables installed under carpet, modular tiles, and planks

(K) Multifamily Dwellings. The following cables, raceways, and cable routing assemblies shall be permitted to be installed in multifamily dwellings in locations other than the locations covered in 800.113(B) through (G):

- (1) Types CMP, CMR, CMG, and CM cables
- (2) Type CMX cables less than 0.25 in. in diameter in nonconcealed spaces
- (3) Plenum, riser, and general-purpose communications raceways
- (4) Riser, and general-purpose cable routing assemblies
- (5) Communications wires and Types CMP, CMR, CMG, and CM cables installed in:

- a. Plenum communications raceways
- b. Riser communications raceways
- c. General-purpose communications raceways

(6) Types CMP, CMR, CMG, and CM cables installed in:

- a. Riser cable routing assemblies
- b. General-purpose cable routing assemblies

(7) Communications wires and Types CMP, CMR, CMG, CM, and CMX cables installed in raceways recognized in Chapter 3

(8) Type CMUC under-carpet communications wires and cables installed under carpet, modular tiles, and planks

(L) One- and Two-Family Dwellings. The following cables, raceways, and cable routing assemblies shall be permitted to be installed in one- and two-family dwellings in locations other than the locations covered in 800.113(B) through 800.113(F):

- (1) Types CMP, CMR, CMG, and CM cables
- (2) Type CMX cables less than 6 mm (0.25 in.) in diameter
- (3) Plenum, riser, and general-purpose communications raceways
- (4) Riser, and general-purpose cable routing assemblies
- (5) Communications wires and Types CMP, CMR, CMG, and CM cables installed in:

- a. Plenum communications raceways
- b. Riser communications raceways
- c. General-purpose communications raceways

(6) Types CMP, CMR, CMG, and CM cables installed in:

- a. Riser cable routing assemblies
- b. General-purpose cable routing assemblies

(7) Communications wires and Types CMP, CMR, CMG, CM, and CMX cables installed in raceways recognized in Chapter 3

(8) Type CMUC under-carpet communications wires and cables installed under carpet, modular tiles, and planks

(9) Hybrid power and communications cable listed in accordance with 800.179(I)"

Revise Table 800.154(a) to read:

"Applications of Listed Communications Wires and Cables in Buildings

Applications		Wire and Cable Type						
		CM P	CM R	CM G CM	CM X	CMU C	Hybrid power & Communi-cation Cables	Communi-cations Wires
In ducts specifically fabricated for environmental air as described in 300.22(B)	In fabricated ducts	N	N	N	N	N	N	N
	In metal raceway that complies with 300.22(B)	Y*	Y*	Y*	Y	N	N	N
In other spaces used for environmental air (plenums) as	In other spaces used for environmental air as described in 300.22(C)	N	N	N	N	N	N	N
	In metal	Y*	Y*	Y*	Y*	N	N	Y*

described in 300.22(C)	raceway that complies with 300.22(C)							
In risers	In vertical runs	Y*	Y*	N	N	N	N	N
	In metal raceways	Y*	Y*	Y*	Y	N	N	N
	In fireproof shafts	Y*	Y*	Y*	Y	N	N	N
	In plenum communications raceways	Y*	Y*	N	N	N	N	N
	In riser communications raceways	Y*	Y*	N	N	N	N	N
	In riser cable routing assemblies	Y*	Y*	N	N	N	N	N
	In one- and two-family dwellings	Y*	Y*	Y*	Y	N	Y*	N
Within buildings in other than air-handling spaces and risers	General	Y*	Y*	Y*	Y	N	N	N
	In one- and two-family dwellings	Y*	Y*	Y*	Y	Y	Y	Y
	In multifamily dwellings	Y*	Y*	Y*	Y	Y	N	N
	In nonconcealed spaces	Y*	Y*	Y*	Y	Y	N	N
	Supported by cable trays	Y*	Y*	Y*	N	N	N	N
	Under carpet or under floor covering, modular tiles & planks	N	N	N	N	Y*	N	N
	In distributing frames and cross-connect arrays	Y*	Y*	Y*	N	N	N	Y
	In any raceway recognized in Chapter 3	Y*	Y*	Y*	Y	N	N	Y
	In plenum communications raceways	Y*	Y*	Y*	Y	N	N	Y
	In riser communications raceways	Y*	Y*	Y*	Y	N	N	Y
In riser cable	Y*	Y*	Y*	Y	N	N	Y	

	routing assemblies							
	In general-purpose communications raceways	Y*	Y*	Y*	Y	N	N	Y
	In general-purpose cable routing assemblies	Y*	Y*	Y*	Y	N	N	Y

Note: An "N" in the table indicates that the cable type is not permitted to be installed in the application. A "Y*" indicates that the cable type is permitted to be installed in the application subject to the limitations described in 800.113.

Informational Note No. 1: Part V of Article 800 covers installation methods within buildings. This table covers the applications of listed communications wires, cables, and raceways in buildings.

Informational Note No. 2: For information on the restrictions to the installation of communications cables in fabricated ducts, see 800.113(B)"

Revise Table 800.154(b) to read:

"Applications of Listed Communications Raceways in Buildings

Applications		Listed Communications Raceway Type		
		Plenum	Riser	General-Purpose
In ducts specifically fabricated for environmental air as described in 300.22(B)	In fabricated ducts	N	N	N
	In metal raceway that complies with 300.22(B)	N	N	N
In other spaces used for environmental air (plenums) as described in 300.22(C)	In other spaces used for environmental air as described in 300.22(C)	N	N	N
	In metal raceway that complies with 300.22(C)	Y*	Y*	Y*
In risers	In vertical runs	Y*	Y*	Y*
	In metal raceways	Y*	Y*	Y*
	In fireproof shafts	Y*	Y*	Y*
	In riser cable routing assemblies	N	N	N
	In one- and two-family dwellings	Y*	Y*	Y*
Within buildings in other than air-handling spaces and risers	General	Y*	Y*	Y*
	In one- and two-family dwellings	Y*	Y*	Y*
	In multifamily dwellings	Y*	Y*	Y*
	In nonconcealed spaces	Y*	Y*	Y*
	Supported by cable trays	Y*	Y*	Y*

	Under carpet or under floor covering, modular tiles & planks	N	N	N
	In distributing frames and cross-connect arrays	Y*	Y*	Y*
	In any raceway recognized in Chapter 3	Y*	Y*	Y*
	In riser cable routing assemblies	N	N	N
	In general-purpose cable routing assemblies	N	N	N

Note: An "N" in the table indicates that the communications raceway type shall not be permitted to be installed in the application. A "Y*" indicates that the communications raceway type shall be permitted to be installed in the application, subject to the limitations described in 800.110 and 800.113"

Revise Table 800.154(c) to read:

"Applications of Listed Cable Routing Assemblies in Buildings

		Listed Communications Raceway Type	
		Riser	General-Purpose
In ducts specifically fabricated for environmental air as described in 300.22(B)	In fabricated ducts	N	N
	In metal raceway that complies with 300.22(B)	N	N
In other spaces used for environmental air (plenums) as described in 300.22(C)	In other spaces used for environmental air as described in 300.22(C)	N	N
	In metal raceway that complies with 300.22(C)	Y*	Y*
In risers	In vertical runs	Y*	Y*
	In metal raceways	Y*	Y*
	In fireproof shafts	Y*	Y*
	In riser cable routing assemblies	N	N
	In one- and two-family dwellings	Y*	Y*
Within buildings in other than air-handling spaces and risers	General	Y*	Y*
	In one- and two-family dwellings	Y*	Y*
	In multifamily dwellings	Y*	Y*
	In nonconcealed spaces	Y*	Y*
	Supported by cable trays	Y*	Y*
	Under carpet or under floor covering, modular tiles & planks	N	N
	In distributing frames and cross-connect arrays	Y*	Y*
In any raceway recognized in	Y*	Y*	

	Chapter 3		
	In riser cable routing assemblies	N	N
	In general-purpose cable routing assemblies	N	N

Note: An "N" in the table indicates that the cable routing assembly type shall not be permitted to be installed in the application. A "Y*" indicates that the cable routing assembly type shall be permitted to be installed in the application, subject to the limitations described in 800.110 and 800.113"

Revise the first paragraph of Section 800.179 to read:

"Communications wires and cables shall be listed in accordance with 800.179(A) through (H) and marked in accordance with Table 800.179. Conductors in communications cables, other than in a coaxial cable, shall be copper."

Delete subsection 800.179(I) and the subsequent informational note.

Revise subsection 800.182(A) to read:

"Plenum Communications Raceways. Plenum communications raceways shall be listed as having adequate fire-resistant and low-smoke-producing characteristics."

Revise Table 800.182(A) to read:

"Table 800.182(a) Cable Routing Assembly Markings

Type	Marking
Riser Cable Routing Assembly	Riser Cable Routing Assembly
General-Purpose Cable Routing Assembly	General-Purpose Routing Assembly

Delete Informational Note No. 3 in subsection 800.182(A).

14E-8-810 Radio and Television Equipment

The provisions of Article 810 of NFPA 70 are adopted by reference without modification.

14E-8-820 Community Antenna Television and Radio Distribution Systems

The provisions of Article 820 of NFPA 70 are adopted by reference with the following modifications:

Revise the first paragraph of section 820.24 to read:

"Community television and radio distribution systems shall be installed in a neat and workmanlike manner. Coaxial cables installed exposed on the surface of ceiling and sidewalls shall be supported by the building structure in such a manner that the cables will not be damaged by normal building use. Such cables shall be secured by hardware

including straps, staples, cable ties, hangers, or similar fittings designed and installed so as not to damage the cable. The installation shall also conform to 300.4(D) and 300.11.”

Delete Informational Note No. 2 under section 820.24, thereby renumbering Informational Note No. 3 as the new Informational Note No. 2.

Revise subsection 820.110(A)(2) to read:

“Communications Raceways. Coaxial cables shall be permitted to be installed in plenum communications raceways, riser communications raceways, and general-purpose communications raceways, selected in accordance with Table 800.154(b), listed in accordance with 800.182, and installed in accordance with 800.113.”

Revise subsection 820.110(C) to read:

“Cable Routing Assemblies. Coaxial cables shall be permitted to be installed in riser cable routing assemblies, and general-purpose cable routing assemblies selected in accordance with Table 800.154(c), listed in accordance with 800.182, and installed in accordance with 800.110(C) and 800.113.”

Revise section 820.113 to read:

“Installation of Coaxial Cables. Installation of coaxial cables shall comply with 820.113(A) through (K). Installation of raceways and cable routing assemblies shall comply with 820.110.

(A) Listing. Coaxial cables installed in buildings shall be listed.

Exception: Coaxial cables that are installed in compliance with 820.48 shall not be required to be listed.

(B) Ducts Specifically Fabricated for Environmental Air. Wires and cables installed in ducts specifically fabricated for environmental air shall be installed in accordance with 300.22(B).

(C) Other Spaces Used For Environmental Air (Plenums). The requirements of 300.22(C) other spaces used for environmental air (plenums) shall apply.

(D) Risers — Cables in Vertical Runs. The following cables shall be permitted in vertical runs penetrating one or more floors and in vertical runs in a shaft:

- (1) Types CATVP and CATVR
- (2) Types CATVP and CATVR installed in the following:
 - a. Plenum communications raceways
 - b. Riser communications raceways
 - c. Riser cable routing assemblies

Informational Note: See 820.26 for firestop requirements for floor penetrations.

(E) Risers — Cables and Innerducts in Metal Raceways. The following cables and

innerducts shall be permitted in metal raceways in a riser having firestops at each floor:

- (1) Types CATVP, CATVR, CATV, and CATVX
- (2) Types CATVP, CATVR, CATV, and CATVX installed in the following:
 - a. Plenum communications raceways (innerduct)
 - b. Riser communications raceways (innerduct)
 - c. General-purpose communications raceways (innerduct)

Informational Note: See 820.26 for firestop requirements for floor penetrations.

(F) Risers — Cables in Fireproof Shafts. The following cables shall be permitted to be installed in fireproof riser shafts with firestops at each floor:

- (1) Types CATVP, CATVR, CATV, and CATVX
- (2) Types CATVP, CATVR, and CATV installed in the following:
 - a. Plenum communications raceways
 - b. Riser communications raceways
 - c. Riser cable routing assemblies
 - d. General-purpose communications raceways
 - e. General-purpose cable routing assemblies

Informational Note: See 820.26 for firestop requirements for floor penetrations.

(G) Risers — One- and Two-Family Dwellings. The following cables shall be permitted in one- and two-family dwellings:

- (1) Types CATVP, CATVR, and CATV
- (2) Type CATVX less than 10 mm ($\frac{3}{8}$ in.) in diameter
- (3) Types CATVP, CATVR, and CATV installed in the following:
 - a. Plenum communications raceways
 - b. Riser communications raceways
 - c. Riser cable routing assemblies
 - d. General-purpose communications raceways
 - e. General-purpose cable routing assemblies

Informational Note: See 820.26 for firestop requirements for floor penetrations.

(H) Cable Trays. The following cables shall be permitted to be supported by cable trays:

- (1) Types CATVP, CATVR, and CATV
- (2) Types CATVP, CATVR, and CATV installed in the following:
 - a. Plenum communications raceways
 - b. Riser communications raceways
 - c. General-purpose communications raceways

(I) Distributing Frames and Cross-Connect Arrays. The following cables shall be

permitted to be installed in distributing frames and cross-connect arrays:

- (1) Types CATVP, CATVR, and CATV
- (2) Types CATVP, CATVR, and CATV installed in the following:
 - a. Plenum communications raceways
 - b. Riser communications raceways
 - c. Riser cable routing assemblies
 - d. General-purpose communications raceways
 - e. General-purpose cable routing assemblies

(J) Other Building Locations. The following cables shall be permitted to be installed in building locations other than the locations covered in 820.113(B) through (I):

- (1) Types CATVP, CATVR, and CATV
- (2) A maximum of 3 m (10 ft) of exposed Type CATVX in non-concealed spaces
- (3) Types CATVP, CATVR, and CATV installed in the following:
 - a. Plenum communications raceways
 - b. Riser communications raceways
 - c. Riser cable routing assemblies
 - d. General-purpose communications raceways
 - e. General-purpose cable routing assemblies

(4) Types CATVP, CATVR, CATV, and CATVX installed in a raceway of a type recognized in Chapter 3

(K) One- and Two-Family and Multifamily Dwellings. The following cables shall be permitted to be installed in one- and two-family and multifamily dwellings in locations other than those locations covered in 820.113(B) through (I):

- (1) Types CATVP, CATVR, and CATV
- (2) Type CATVX less than 10 mm ($\frac{3}{8}$ in.) in diameter
- (3) Types CATVP, CATVR, and CATV installed in the following:
 - a. Plenum communications raceways
 - b. Riser communications raceways
 - c. Riser cable routing assemblies
 - d. General-purpose communications raceways
 - e. General-purpose cable routing assemblies

(4) Types CATVP, CATVR, CATV, and CATVX installed in a raceway of a type recognized in Chapter 3.”

Revise Table 820.154(a) to read:

“Applications of Listed Coaxial Cables in Buildings

Applications		Listed Coaxial Cable Type			
		CATVP	CATVR	CATV	CATVX
In ducts specifically fabricated for environmental air as described in 300.22(B)	In fabricated ducts as described in 300.22(B)	N	N	N	N
	In metal raceway that complies with 300.22(B)	Y*	Y*	Y*	Y*
In other spaces used for environmental air (plenums) as described in 300.22(C)	In other spaces used for environmental air as described in 300.22(C)	N	N	N	N
	In metal raceway that complies with 300.22(C)	Y*	Y*	Y*	Y*
	In plenum communications raceways	N	N	N	N
In risers	In vertical runs	Y*	Y*	N	N
	In metal raceways	Y*	Y*	Y*	Y*
	In fireproof shafts	Y*	Y*	Y*	Y*
	In plenum communications raceways	Y*	Y*	N	N
	In riser communications raceways	Y*	Y*	N	N
	In riser cable routing assemblies	Y*	Y*	N	N
	In one- and two-family dwellings	Y*	Y*	Y*	Y*
Within buildings in other than air-handling spaces and risers	General	Y*	Y*	Y*	Y*
	In one- and two-family dwellings	Y*	Y*	Y*	Y*
	In multifamily dwellings	Y*	Y*	Y*	Y*
	In non-concealed spaces	Y*	Y*	Y*	Y*
	Supported by cable trays	Y*	Y*	Y*	N
	In distributing frames and cross-connect arrays	Y*	Y*	Y*	N
	In any raceway recognized in Chapter 3	Y*	Y*	Y*	Y*
	In plenum communications raceways	Y*	Y*	Y*	N
	In riser communications raceways	Y*	Y*	Y*	N
	In riser cable routing assemblies	Y*	Y*	Y*	N
	In general-purpose communications raceways	Y*	Y*	Y*	N
	In general-purpose cable routing assemblies	Y*	Y*	Y*	N

Note: An "N" in the table indicates that the cable type is not permitted to be installed in the application. A "Y*" indicates that the cable type is permitted to be installed in the application, subject to the limitations described in 820.113.

Informational Note No. 1: Part V of Article 820 covers installation methods within buildings. This table covers the applications of listed coaxial cables in buildings. The definition of Point of Entrance is in 820.2.

Informational Note No. 2: For information on the restrictions to the installation of communications cables in ducts specifically fabricated for environmental air, see 820.113(B).”

14E-8-830 Network-Powered Broadband Communications Systems

The provisions of Article 830 of NFPA 70 are adopted by reference with the following modifications:

Revise subsection 830.110(C) to read:

“Cable Routing Assemblies. Low-power network-powered broadband communications cables shall be permitted to be installed in riser cable routing assemblies, and general-purpose cable routing assemblies selected in accordance with Table 800.154(c), listed in accordance with 800.182, and installed in accordance with 800.110(C) and 800.113.”

Revise subsections 830.113 (B) through (I) to read:

“(B) Ducts Specifically Fabricated for Environmental Air. Wires and cables installed in ducts specifically fabricated for environmental air shall be installed in accordance with 22(B).

(C) Other Spaces Used for Environmental Air (Plenums). Wires and cables installed in other spaces used for environmental air (plenums) shall be installed in accordance with 300.22(C).

(D) Risers — Cables in Vertical Runs. The following cables shall be permitted in vertical runs penetrating one or more floors and in vertical runs in a shaft:

- (1) Types BLP, BMR, and BLR
- (2) Types BLP and BLR installed in the following:
 - a. Plenum communications raceways
 - b. Riser communications raceways
 - c. Riser cable routing assemblies

Informational Note: See 830.26 for firestop requirements for floor penetrations.

(E) Risers — Cables and Innerducts in Metal Raceways. The following cables and innerducts shall be permitted in a metal raceway in a riser with firestops at each floor:

- (1) Types BLP, BMR, BLR, BM, BL, and BLX
- (2) Types BLP, BLR, and BL installed in the following:
 - a. Plenum communications raceways (innerduct)
 - b. Riser communications raceways (innerduct)
 - c. General-purpose communications raceways (innerduct)

Informational Note: See 830.26 for firestop requirements for floor penetrations.

(F) Risers — Cables in Fireproof Shafts. The following cables shall be permitted to be installed in fireproof riser shafts with firestops at each floor:

- (1) Types BLP, BMR, BLR, BM, BL, and BLX
- (2) Types BLP, BLR, and BL installed in the following:
 - a. Plenum communications raceways
 - b. Riser communications raceways
 - c. Riser cable routing assemblies
 - d. General-purpose communications raceways
 - e. General-purpose cable routing assemblies

Informational Note: See 830.26 for firestop requirements for floor penetrations.

(G) Risers — One- and Two-Family Dwellings. The following cables shall be permitted in one- and two-family dwellings:

- (1) Types BLP, BMR, BLR, BM, BL, and BLX less than 10 mm ($\frac{3}{8}$ in.) in diameter
- (2) Types BLP, BLR, and BL installed in the following:
 - a. Plenum communications raceways
 - b. Riser communications raceways
 - c. Riser cable routing assemblies
 - d. General-purpose communications raceways
 - e. General-purpose cable routing assemblies

Informational Note: See 830.26 for firestop requirements for floor penetrations.

(H) Cable Trays. The following cables shall be permitted to be supported by cable trays:

- (1) Types BLP, BMR, BLR, BM, and BL
- (2) Types BLP, BLR, and BL installed in the following:
 - a. Plenum communications raceways
 - b. Riser communications raceways
 - c. General-purpose communications raceways

(I) Other Building Locations. The following cables shall be permitted to be installed in building locations other than those covered in 830.113(B) through (H):

- (1) Types BLP, BMR, BLR, BM, and BL
- (2) Types BLP, BMR, BLR, BM, BL, and BLX installed in raceways recognized in Chapter 3
- (3) Types BLP, BLR, and BL installed in the following:
 - a. Plenum communications raceways
 - b. Riser communications raceways
 - c. Riser cable routing assemblies

- d. General-purpose communications raceways
- e. General-purpose cable routing assemblies

- (4) Type BLX less than 10 mm (3/8 in.) in diameter in one-and two-family dwellings
- (5) Types BMU and BLU entering the building from outside and run in rigid metal conduit (RMC) or intermediate metal conduit (IMC) where the conduit is connected by a bonding conductor or grounding electrode conductor in accordance with 830.100(B)

Informational Note: This provision limits the length of Type BLX cable to 15.2 m (50 ft), while 830.90(B) requires that the primary protector, or NIU with integral protection, be located as close as practicable to the point at which the cable enters the building. Therefore, in installations requiring a primary protector, or NIU with integral protection, Type BLX cable may not be permitted to extend 15.2 m (50 ft) into the building if it is practicable to place the primary protector closer than 15.2 m (50 ft) to the entrance point.

- (6) A maximum length of 15.2 m (50 ft), within the building, of Type BLX cable entering the building from outside and terminating at an NIU or a primary protection location.”

Revise Table 830.154(a) to read:

“Applications of Listed Network-Powered Broadband Cables In Buildings

Applications		Listed Coaxial Cable Type						
		BLP	BLR	BL	BMR	BM	BLX	BMU, BLU
In ducts specifically fabricated for environmental air as described in 300.22(B)	In fabricated ducts as described in 300.22(B)	N	N	N	N	N	N	N
	In metal raceway that complies with 300.22(B)	Y*	Y*	Y*	Y*	Y*	Y*	N
In other spaces used for environmental air (plenums) as described in 300.22(C)	In other spaces used for environmental air as described in 300.22(C)	N	N	N	N	N	N	N
	In metal raceway that complies with 300.22(C)	Y*	Y*	Y*	Y*	Y*	Y*	Y*
In risers	In vertical runs	Y*	Y*	N	Y*	N	N	N
	In metal raceways	Y*	Y*	Y*	Y*	Y*	Y*	N
	In fireproof shafts	Y*	Y*	Y*	Y*	Y*	Y*	N
	In plenum communications raceways	Y*	Y*	N	N	N	N	N
	In riser communications raceways	Y*	Y*	N	N	N	N	N
	In riser cable routing assemblies	Y*	Y*	N	N	N	N	N
	In one- and two-family dwellings	Y*	Y*	Y*	Y*	Y*	Y*	N

Within buildings in other than air-handling spaces and risers	General	Y*	Y*	Y*	Y*	Y*	Y*	N
	In one- and two-family dwellings	Y*	Y*	Y*	Y*	Y*	Y*	N
	Supported by cable trays	Y*	Y*	Y*	Y*	Y*	N	N
	In rigid metal conduit (RMC) and intermediate metal conduit (IMC)	Y*	Y*	Y*	Y*	Y*	Y*	Y*
	In any raceway recognized in Chapter 3	Y*	Y*	Y*	Y*	Y*	Y*	N
	In plenum communications raceways	Y*	Y*	Y*	N	N	N	N
	In riser communications raceways	Y*	Y*	Y*	N	N	N	N
	In riser cable routing assemblies	Y*	Y*	Y*	N	N	N	N
	In general-purpose communications raceways	Y*	Y*	Y*	N	N	N	N
	In general-purpose cable routing assemblies	Y*	Y*	Y*	N	N	N	N

Note: An "N" in the table indicates that the cable type shall not be permitted to be installed in the application. A "Y," indicates that the cable type shall be permitted to be installed in the application subject to the limitations described in 830.113.

Informational Note No. 1: Part V of Article 830 covers installation methods within buildings. This table covers the applications of listed network-powered broadband communications cables in buildings. The definition of Point of Entrance is in 830.2.

Informational Note No. 2: For information on the restrictions to the installation of network-powered broadband communications cables in ducts specifically fabricated for environmental air, see 830.113(B)."

14E-8-840 Premises-Powered Broadband Communications Systems

The provisions of Article 840 of NFPA 70 are adopted by reference without modification.

CHAPTER 14E-9 TABLES

14E-9-001 Percent of Cross Section of Conduit and Tubing for Conductors and Cables

Chapter 9, Table 1 of NFPA 70 is adopted by reference with the following modification:

Revise Note 1 to read:

See Informative Annex C for the maximum number of selected carrying-conductors (Types THHN, THWN, and THWN-2 only), all of the same size (total cross-sectional area including insulation) permitted in trade sizes of the applicable conduit or tubing.

14E-9-002 Radius of Conduit and Tubing Bends

Chapter 9, Table 2 of NFPA 70 are adopted by reference without modification.

14E-9-004 Radius of Conduit and Tubing Bends

Chapter 9, Table 4 of NFPA 70 is adopted by reference without modification.

14E-9-005 Dimensions of Insulated Conductors and Fixture Wires and Compact Copper and Aluminum Building Wire Nominal Dimensions and Areas

Chapter 9, Tables 5 and 5A of NFPA 70 are adopted by reference without modification.

14E-9-008 Conductor Properties

Chapter 9, Table 8 of NFPA 70 is adopted by reference without modification.

14E-9-009 Alternating-Current Resistance and Reactance for 600-volt Cables, 3-Phase, 60 Hz, 75°C (167°F) – Three Single Conductors in Conduit

Chapter 9, Table 9 of NFPA 70 is adopted by reference without modification.

14E-9-010 Conductor Stranding

Chapter 9, Table 10 of NFPA 70 is adopted by reference without modification.

14E-9-011 Class 2 and Class 3 Power Source Limitations

Chapter 9, Tables 11(A) and 11(B) of NFPA 70 are adopted by reference without modification.

14E-9-012 PLFA Power Source Limitations

Chapter 9, Tables 12(A) and 12(B) of NFPA 70 are adopted by reference without modification.

CHAPTER 14E-10 INFORMATIVE ANNEXES

14E-10-010 Informative Annexes.

These informative annexes are not part of the enforceable requirements of this Title, but are included for information purposes only.

Informative Annex A of NFPA 70 is adopted by reference without modification.

Informative Annex B of NFPA 70 is adopted by reference without modification.

3. The following tables are adopted as Informative Annex C, entitled “Conduit and Tubing Fill Tables for Conductors and Fixture Wires of the Same Size”:

**Table C.1 - Number of The Same Size Conductors in Trade Size of Conduit or Tubing Electrical Metallic Tubing (EMT)
Conductor Types THHN, THWN, THWN-2 (Based on Table 1, Chapter 9)**

	100%			80%			70%		
	1	2	3	4	5	6	7	8	9
14	1/2	1/2	1/2	1/2	1/2	1/2	1/2	1/2	1/2
12	1/2	1/2	1/2	1/2	1/2	1/2	1/2	1/2	1/2
10	1/2	1/2	1/2	1/2	1/2	3/4	3/4	3/4	3/4
8	1/2	1/2	1/2	3/4	3/4	3/4	1	1	1
6	1/2	1/2	3/4	3/4	1	1	1	1 1/4	1 1/4
4	1/2	3/4	1	1	1 1/4	1 1/4	1 1/4	1 1/2	1 1/2
3	1/2	1	1	1 1/4	1 1/4	1 1/4	1 1/2	1 1/2	2
2	1/2	1	1	1 1/4	1 1/4	1 1/2	1 1/2	2	2
1	1/2	1 1/4	1 1/4	1 1/4	1 1/2	2	2	2	2 1/2
1/0	1/2	1 1/4	1 1/4	1 1/2	2	2	2	2 1/2	2 1/2
2/0	3/4	1 1/4	1 1/2	2	2	2	2 1/2	2 1/2	2 1/2
3/0	3/4	1 1/2	1 1/2	2	2	2 1/2	2 1/2	2 1/2	3
4/0	3/4	1 1/2	2	2	2 1/2	2 1/2	2 1/2	3	3
250	1	2	2	2 1/2	2 1/2	2 1/2	3	3	3
300	1	2	2	2 1/2	2 1/2	3	3	3 1/2	3 1/2
350	1	2	2 1/2	2 1/2	3	3	3 1/2	3 1/2	3 1/2
400	1 1/4	2 1/2	2 1/2	2 1/2	3	3	3 1/2	3 1/2	4
500	1 1/4	2 1/2	2 1/2	3	3	3 1/2	4	4	---
600	1 1/4	2 1/2	3	3	3 1/2	4	4	---	---
700	1 1/4	2 1/2	3	3 1/2	4	4	---	---	---
750	1 1/2	3	3	3 1/2	4	---	---	---	---
800	1 1/2	3	3	3 1/2	4	---	---	---	---
900	1 1/2	3	3	4	---	---	---	---	---
1000	1 1/2	3	3 1/2	4	---	---	---	---	---

Table C.1(A) - Number of The Same Size Compact Stranded Conductors in Trade Size of Conduit or Tubing
Electrical Metallic Tubing (EMT)
Conductor Types THHN (Based on Table 1, Chapter 9)

	100%			80%			70%		
	1	2	3	4	5	6	7	8	9
6	1/2	1/2	3/4	3/4	1	1	1	1 1/4	1 1/4
4	1/2	3/4	3/4	1	1 1/4	1 1/4	1 1/4	1 1/4	1 1/2
2	1/2	1	1	1 1/4	1 1/4	1 1/4	1 1/2	1 1/2	2
1	1/2	1	1 1/4	1 1/4	1 1/2	1 1/2	2	2	2
1/0	1/2	1 1/4	1 1/4	1 1/2	1 1/2	2	2	2	2 1/2
2/0	1/2	1 1/4	1 1/4	1 1/2	2	2	2	2 1/2	2 1/2
3/0	3/4	1 1/4	1 1/2	2	2	2	2 1/2	2 1/2	2 1/2
4/0	3/4	1 1/2	1 1/2	2	2	2 1/2	2 1/2	2 1/2	3
250	3/4	2	2	2	2 1/2	2 1/2	3	3	3
300	1	2	2	2 1/2	2 1/2	3	3	3	3 1/2
350	1	2	2	2 1/2	2 1/2	3	3	3 1/2	3 1/2
400	1	2	2 1/2	2 1/2	3	3	3 1/2	3 1/2	3 1/2
500	1 1/4	2 1/2	2 1/2	2 1/2	3	3 1/2	3 1/2	4	4
600	1 1/4	2 1/2	2 1/2	3	3 1/2	3 1/2	4	---	---

700	1 ¼	2 ½	3	3	3 ½	4	4	---	---
750	1 ¼	2 ½	3	3	3 ½	4	---	---	---
1000	1 ½	3	3	4	---	---	---	---	---

**Table C.3 - Number of The Same Size Conductors in Trade Size of Conduit or Tubing
Flexible Metal Conduit (FMC)**

	Conductor Types THHN, THWN, THWN-2 (Based on Table 1, Chapter 9)			80%			70%		
	100%								
	1	2	3	4	5	6	7	8	9
14	—	—	—	—	½	½	½	½	½
12	—	—	—	½	½	½	½	½	½
10	—	½	½	½	½	½	¾	¾	¾
8	—	½	½	¾	¾	¾	1	1	1
6	—	½	¾	¾	1	1	1 ¼	1 ¼	1 ¼
4	½	¾	1	1	1 ¼	1 ¼	2	2	2
3	½	1	1	1 ¼	1 ¼	2	2	2	2
2	½	1	1	1 ¼	2	2	2	2	2
1	½	1 ¼	1 ¼	2	2	2	2	2	2 ½
1/0	½	1 ¼	2	2	2	2	2	2 ½	2 ½
2/0	¾	1 ½	2	2	2	2	2 ½	2 ½	2 ½
3/0	¾	1 ½	2	2	2	2 ½	2 ½	3	3
4/0	¾	2	2	2	2 ½	2 ½	3	3	3 ½
250	1	2	2	2 ½	2 ½	3	3	3 ½	3 ½
300	1	2	2	2 ½	3	3	3 ½	3 ½	4
350	1	2	2 ½	3	3	3 ½	3 ½	4	4
400	1 ¼	2 ½	2 ½	3	3	3 ½	4	4	---
500	1 ¼	2 ½	3	3	3 ½	4	4	---	---
600	1 ½	3	3	3 ½	4	---	---	---	---
700	1 ½	3	3	3 ½	4	---	---	---	---
750	1 ½	3	3 ½	4	---	---	---	---	---
800	1 ½	3	3 ½	4	---	---	---	---	---
900	2	3 ½	3 ½	4	---	---	---	---	---
1000	2	3 ½	3 ½	---	---	---	---	---	---

**Table C.3(A) - Number of The Same Size Compact Stranded Conductors in Trade Size of
Conduit or Tubing**

	Conductor Types THHN (Based on Table 1, Chapter 9)			80%			70%		
	100%								
	1	2	3	4	5	6	7	8	9
6	—	½	½	¾	1	1	1	1 ¼	1 ¼
4	—	¾	¾	1	1 ¼	1 ¼	1 ¼	2	2
2	½	1	1	1 ¼	1 ¼	2	2	2	2
1	½	1	1 ¼	2	2	2	2	2	2
1/0	½	1 ¼	1 ¼	2	2	2	2	2	2 ½
2/0	½	1 ¼	2	2	2	2	2 ½	2 ½	2 ½
3/0	¾	1 ½	2	2	2	2 ½	2 ½	2 ½	3
4/0	¾	1 ½	2	2	2 ½	2 ½	2 ½	3	3

250	1	2	2	2 ½	2 ½	3	3	3	3 ½
300	1	2	2	2 ½	2 ½	3	3	3 ½	3 ½
350	1	2	2	2 ½	3	3	3 ½	3 ½	4
400	1	2	2 ½	3	3	3 ½	3 ½	4	4
500	1 ¼	2 ½	2 ½	3	3 ½	3 ½	4	4	---
600	1 ¼	2 ½	3	3 ½	3 ½	4	---	---	---
700	1 ½	3	3	3 ½	4	4	---	---	---
750	1 ½	3	3	3 ½	4	---	---	---	---
1000	2	3 ½	3 ½	4	---	---	---	---	---

Table C.4 - Number of The Same Size Conductors in Trade Size of Conduit or Tubing Intermediate Metal Conduit (IMC)

Conductor Types THHN, THWN, THWN-2 (Based on Table 1, Chapter 9)

	100%			80%			70%		
	1	2	3	4	5	6	7	8	9
14	½	½	½	½	½	½	½	½	½
12	½	½	½	½	½	½	½	½	½
10	½	½	½	½	½	½	¾	¾	¾
8	½	½	½	¾	¾	¾	1	1	1
6	½	½	¾	¾	1	1	1	1 ¼	1 ¼
4	½	¾	¾	1	1 ¼	1 ¼	1 ¼	1 ¼	1 ½
3	½	¾	1	1	1 ¼	1 ¼	1 ½	1 ½	1 ½
2	½	1	1	1 ¼	1 ¼	1 ½	1 ½	2	2
1	½	1	1 ¼	1 ¼	1 ½	2	2	2	2
1/0	½	1 ¼	1 ¼	1 ½	2	2	2	2	2 ½
2/0	½	1 ¼	1 ¼	1 ½	2	2	2 ½	2 ½	2 ½
3/0	¾	1 ¼	1 ½	2	2	2 ½	2 ½	3	3
4/0	¾	1 ½	2	2	2 ½	2 ½	3	3	3
250	1	2	2	2 ½	2 ½	3	3	3	3 ½
300	1	2	2	2 ½	3	3	3	3 ½	3 ½
350	1	2	2 ½	2 ½	3	3	3 ½	3 ½	4
400	1	2	2 ½	3	3	3 ½	3 ½	4	4
500	1 ¼	2 ½	2 ½	3	3 ½	3 ½	4	---	---
600	1 ¼	2 ½	3	3 ½	3 ½	4	---	---	---
700	1 ¼	3	3	3 ½	4	---	---	---	---
750	1 ¼	3	3	3 ½	4	---	---	---	---
800	1 ½	3	3	3 ½	4	---	---	---	---
900	1 ½	3	3 ½	4	---	---	---	---	---
1000	1 ½	3	3 ½	4	---	---	---	---	---

Table C.4(A) - Number of The Same Size Compact Stranded Conductors in Trade Size of Conduit or Tubing Intermediate Metal Conduit (IMC)

Conductor Types THHN (Based on Table 1, Chapter 9)

	100%			80%			70%		
	1	2	3	4	5	6	7	8	9
6	½	½	½	¾	¾	1	1	1	1 ¼
4	½	¾	¾	1	1	1 ¼	1 ¼	1 ¼	1 ¼
2	½	1	1	1 ¼	1 ¼	1 ¼	1 ½	1 ½	2
1	½	1	1	1 ¼	1 ¼	1 ½	2	2	2
1/0	½	1	1 ¼	1 ¼	1 ½	2	2	2	2
2/0	½	1 ¼	1 ¼	1 ½	2	2	2	2 ½	2 ½
3/0	¾	1 ¼	1 ¼	1 ½	2	2	2 ½	2 ½	2 ½
4/0	¾	1 ¼	1 ½	2	2	2 ½	2 ½	3	3
250	¾	1 ½	2	2	2 ½	2 ½	3	3	3
300	1	2	2	2 ½	2 ½	3	3	3 ½	3 ½
350	1	2	2	2 ½	3	3	3	3 ½	3 ½
400	1	2	2 ½	2 ½	3	3	3 ½	3 ½	4
500	1	2	2 ½	3	3	3 ½	3 ½	4	4
600	1 ¼	2 ½	3	3	3 ½	4	4	---	---
700	1 ¼	2 ½	3	3 ½	3 ½	4	---	---	---
750	1 ¼	3	3	3 ½	4	4	---	---	---
1000	1 ½	3	3 ½	4	---	---	---	---	---

**Table C.8 - Number of The Same Size Conductors in Trade Size of Conduit or Tubing
Liquidtight Flexible Metal Conduit (LFMC)**

Conductor Types THHN, THWN, THWN-2 (Based on Table 1, Chapter 9)

	100%			80%			70%		
	1	2	3	4	5	6	7	8	9
14	—	—	—	—	—	—	—	—	½
12	—	—	—	—	—	½	½	½	½
10	—	—	—	½	½	½	¾	¾	¾
8	—	½	½	¾	¾	¾	1	1	1
6	—	½	¾	¾	1	1	1	1 ¼	1 ¼
4	—	¾	1	1	1 ¼	1 ¼	1 ¼	1 ½	1 ½
3	—	1	1	1 ¼	1 ¼	1 ¼	1 ½	1 ½	2
2	—	1	1	1 ¼	1 ¼	1 ½	1 ½	2	2
1	½	1 ¼	1 ¼	1 ¼	1 ½	2	2	2	2 ½
1/0	½	1 ¼	1 ¼	1 ½	2	2	2	2 ½	2 ½
2/0	¾	1 ¼	1 ½	2	2	2	2 ½	2 ½	3
3/0	¾	1 ½	1 ½	2	2	2 ½	2 ½	3	3
4/0	¾	1 ½	2	2	2 ½	2 ½	3	3	3
250	1	2	2	2 ½	2 ½	3	3	3 ½	3 ½
300	1	2	2	2 ½	3	3	3 ½	3 ½	4
350	1	2	2 ½	3	3	3 ½	3 ½	4	4
400	1 ¼	2 ½	2 ½	3	3	3 ½	4	4	---
500	1 ¼	2 ½	3	3	3 ½	4	4	---	---
600	1 ¼	3	3	3 ½	4	4	---	---	---
700	1 ¼	3	3	3 ½	4	---	---	---	---
750	1 ½	3	3	4	4	---	---	---	---
800	1 ½	3	3 ½	4	---	---	---	---	---

900	1 ½	3	3 ½	4	---	---	---	---	---
1000	2	3 ½	3 ½	---	---	---	---	---	---

Table C.8(A) - Number of The Same Size Compact Stranded Conductors in Trade Size of Conduit or Tubing

Liquidtight Flexible Metal Conduit (LFMC)
Conductor Types THHN (Based on Table 1, Chapter 9)

	100%			80%			70%		
	1	2	3	4	5	6	7	8	9
6	—	½	¾	¾	1	1	1	1 ¼	1 ¼
4	—	¾	¾	1	1 ¼	1 ¼	1 ¼	1 ¼	1 ½
2	—	1	1	1 ¼	1 ¼	1 ¼	1 ½	2	2
1	½	1	1 ¼	1 ¼	1 ½	1 ½	2	2	2
1/0	½	1 ¼	1 ¼	1 ¼	1 ½	2	2	2	2 ½
2/0	½	1 ¼	1 ¼	1 ½	2	2	2 ½	2 ½	2 ½
3/0	¾	1 ¼	1 ½	2	2	2 ½	2 ½	2 ½	3
4/0	¾	1 ½	1 ½	2	2 ½	2 ½	2 ½	3	3
250	¾	2	2	2 ½	2 ½	3	3	3	3 ½
300	1	2	2	2 ½	3	3	3	3 ½	3 ½
350	1	2	2 ½	2 ½	3	3	3 ½	3 ½	4
400	1	2	2 ½	3	3	3 ½	3 ½	4	4
500	1 ¼	2 ½	2 ½	3	3	3 ½	4	4	---
600	1 ¼	2 ½	3	3	3 ½	4	---	---	---
700	1 ¼	3	3	3 ½	4	4	---	---	---
750	1 ¼	3	3	3 ½	4	---	---	---	---
1000	1 ½	3	3 ½	4	---	---	---	---	---

Table C.9 - Number of The Same Size Conductors in Trade Size of Conduit or Tubing

Rigid Metal Conduit (RMC)
Conductor Types THHN, THWN, THWN-2 (Based on Table 1, Chapter 9)

	100%			80%			70%		
	1	2	3	4	5	6	7	8	9
14	½	½	½	½	½	½	½	½	½
12	½	½	½	½	½	½	½	½	½
10	½	½	½	½	½	½	¾	¾	¾
8	½	½	½	¾	¾	¾	1	1	1
6	½	½	¾	¾	1	1	1	1 ¼	1 ¼
4	½	¾	1	1	1 ¼	1 ¼	1 ¼	1 ½	1 ½
3	½	1	1	1 ¼	1 ¼	1 ¼	1 ½	1 ½	2
2	½	1	1	1 ¼	1 ¼	1 ½	1 ½	2	2
1	½	1 ¼	1 ¼	1 ¼	1 ½	2	2	2	2 ½
1/0	½	1 ¼	1 ¼	1 ½	2	2	2	2 ½	2 ½
2/0	¾	1 ¼	1 ½	2	2	2	2 ½	2 ½	3
3/0	¾	1 ½	1 ½	2	2	2 ½	2 ½	3	3
4/0	¾	1 ½	2	2	2 ½	2 ½	3	3	3
250	1	2	2	2 ½	2 ½	3	3	3 ½	3 ½
300	1	2	2	2 ½	3	3	3 ½	3 ½	4
350	1	2	2 ½	3	3	3 ½	3 ½	4	4

400	1	2	2 ½	3	3	3 ½	3 ½	4	5
500	1 ¼	2 ½	3	3	3 ½	4	4	5	5
600	1 ¼	3	3	3 ½	4	4	5	5	5
700	1 ¼	3	3	3 ½	4	5	5	5	6
750	1 ½	3	3	3 ½	4	5	5	6	6
800	1 ½	3	3 ½	4	5	5	5	6	6
900	1 ½	3	3 ½	4	5	5	6	6	6
1000	1 ½	3 ½	3 ½	4	5	5	6	6	---

Table C.9(A) - Number of The Same Size Compact Stranded Conductors in Trade Size of Conduit or Tubing

Rigid Metal Conduit (RMC)

Conductor Types THHN (Based on Table 1, Chapter 9)

	100%			80%			70%		
	1	2	3	4	5	6	7	8	9
6	½	½	¾	¾	¾	1	1	1	1 ¼
4	½	¾	¾	1	1	1 ¼	1 ¼	1 ¼	1 ½
2	½	1	1	1 ¼	1 ¼	1 ¼	1 ½	1 ½	2
1	½	1	1 ¼	1 ¼	1 ½	1 ½	2	2	2
1/0	½	1 ¼	1 ¼	1 ¼	1 ½	2	2	2	2 ½
2/0	½	1 ¼	1 ¼	1 ½	2	2	2	2 ½	2 ½
3/0	¾	1 ¼	1 ½	2	2	2	2 ½	2 ½	3
4/0	¾	1 ½	1 ½	2	2	2 ½	2 ½	3	3
250	¾	1 ½	2	2	2 ½	3	3	3	3 ½
300	1	2	2	2 ½	3	3	3	3 ½	3 ½
350	1	2	2	2 ½	3	3	3 ½	3 ½	4
400	1	2	2 ½	3	3	3 ½	3 ½	4	4
500	1 ¼	2 ½	2 ½	3	3	3 ½	4	4	5
600	1 ¼	2 ½	3	3	3 ½	4	5	5	5
700	1 ¼	3	3	3 ½	4	4	5	5	5
750	1 ¼	3	3	3 ½	4	5	5	5	5
1000	1 ½	3	3 ½	4	5	5	6	6	6

Table C.10 - Number of The Same Size Conductors in Trade Size of Conduit or Tubing

Rigid PVC Conduit, Schedule 80

Conductor Types THHN, THWN, THWN-2 (Based on Table 1, Chapter 9)

	100%			80%			70%		
	1	2	3	4	5	6	7	8	9
14	½	½	½	½	½	½	½	½	½
12	½	½	½	½	½	½	¾	¾	¾
10	½	½	½	½	¾	¾	¾	1	1
8	½	½	¾	¾	1	1	1	1 ¼	1 ¼
6	½	¾	¾	1	1	1 ¼	1 ¼	1 ¼	1 ¼
4	½	1	1	1 ¼	1 ¼	1 ¼	1 ½	1 ½	2
3	½	1	1	1 ¼	1 ¼	1 ½	1 ½	2	2
2	½	1	1 ¼	1 ¼	1 ½	1 ½	2	2	2
1	¾	1 ¼	1 ¼	1 ½	2	2	2	2 ½	2 ½
1/0	¾	1 ¼	1 ½	2	2	2	2 ½	2 ½	2 ½

2/0	¾	1 ½	1 ½	2	2	2 ½	2 ½	3	3
3/0	¾	1 ½	2	2	2 ½	2 ½	3	3	3
4/0	1	2	2	2 ½	2 ½	3	3	3	3 ½
250	1	2	2	2 ½	3	3	3 ½	3 ½	4
300	1 ¼	2	2 ½	3	3	3 ½	3 ½	4	4
350	1 ¼	2 ½	2 ½	3	3	3 ½	4	4	5
400	1 ¼	2 ½	2 ½	3	3 ½	3 ½	4	5	5
500	1 ¼	2 ½	3	3 ½	3 ½	4	5	5	5
600	1 ½	3	3	3 ½	4	5	5	5	6
700	1 ½	3	3 ½	4	5	5	5	6	6
750	1 ½	3	3 ½	4	5	5	5	6	6
800	1 ½	3	3 ½	4	5	5	6	6	6
900	2	3 ½	3 ½	5	5	5	6	6	---
1000	2	3 ½	4	5	5	6	6	---	---

Table C.10(A) - Number of The Same Size Compact Stranded Conductors in Trade Size of Conduit or Tubing

Rigid PVC Conduit, Schedule 80

Conductor Types THHN (Based on Table 1, Chapter 9)

	100%			80%			70%		
	1	2	3	4	5	6	7	8	9
6	½	¾	¾	1	1	1	1 ¼	1 ¼	1 ¼
4	½	1	1	1 ¼	1 ¼	1 ¼	1 ½	1 ½	1 ½
2	½	1	1 ¼	1 ¼	1 ¼	1 ½	2	2	2
1	½	1 ¼	1 ¼	1 ½	1 ½	2	2	2	2 ½
1/0	¾	1 ¼	1 ¼	1 ½	2	2	2	2 ½	2 ½
2/0	¾	1 ¼	1 ½	2	2	2	2 ½	2 ½	3
3/0	¾	1 ½	1 ½	2	2	2 ½	2 ½	3	3
4/0	1	1 ½	2	2	2 ½	2 ½	3	3	3
250	1	2	2	2 ½	3	3	3	3 ½	3 ½
300	1	2	2	2 ½	3	3	3 ½	3 ½	4
350	1 ¼	2	2 ½	3	3	3 ½	3 ½	4	4
400	1 ¼	2 ½	2 ½	3	3	3 ½	4	4	5
500	1 ¼	2 ½	3	3	3 ½	4	4	5	5
600	1 ¼	3	3	3 ½	4	4	5	5	5
700	1 ½	3	3	3 ½	4	5	5	5	6
750	1 ½	3	3	3 ½	4	5	5	5	6
1000	2	3 ½	3 ½	5	5	6	6	6	---

Table C.11 - Number of The Same Size Conductors in Trade Size of Conduit or Tubing

Rigid PVC Conduit, Schedule 40

Conductor Types THHN, THWN, THWN-2 (Based on Table 1, Chapter 9)

	100%			80%			70%		
	1	2	3	4	5	6	7	8	9
14	1/2	1/2	1/2	1/2	1/2	1/2	1/2	1/2	1/2
12	1/2	1/2	1/2	1/2	1/2	1/2	1/2	1/2	3/4
10	1/2	1/2	1/2	1/2	1/2	3/4	3/4	3/4	3/4
8	1/2	1/2	1/2	3/4	3/4	1	1	1	1
6	1/2	3/4	3/4	3/4	1	1	1 1/4	1 1/4	1 1/4
4	1/2	3/4	1	1	1 1/4	1 1/4	1 1/4	1 1/2	1 1/2
3	1/2	1	1	1 1/4	1 1/4	1 1/4	1 1/2	1 1/2	2
2	1/2	1	1	1 1/4	1 1/4	1 1/2	1 1/2	2	2
1	1/2	1 1/4	1 1/4	1 1/2	1 1/2	2	2	2	2 1/2
1/0	1/2	1 1/4	1 1/4	1 1/2	2	2	2	2 1/2	2 1/2
2/0	3/4	1 1/4	1 1/2	2	2	2	2 1/2	2 1/2	3
3/0	3/4	1 1/2	1 1/2	2	2	2 1/2	2 1/2	3	3
4/0	3/4	1 1/2	2	2	2 1/2	2 1/2	3	3	3
250	1	2	2	2 1/2	3	3	3	3 1/2	3 1/2
300	1	2	2	2 1/2	3	3	3 1/2	3 1/2	4
350	1	2	2 1/2	3	3	3 1/2	3 1/2	4	4
400	1 1/4	2 1/2	2 1/2	3	3	3 1/2	4	4	5
500	1 1/4	2 1/2	3	3	3 1/2	4	4	5	5
600	1 1/4	3	3	3 1/2	4	5	5	5	5
700	1 1/2	3	3	3 1/2	4	5	5	5	6
750	1 1/2	3	3 1/2	4	5	5	5	6	6
800	1 1/2	3	3 1/2	4	5	5	5	6	6
900	1 1/2	3	3 1/2	4	5	5	6	6	6
1000	2	3 1/2	3 1/2	5	5	5	6	6	---

Table C.11(A) - Number of The Same Size Compact Stranded Conductors in Trade Size of Conduit or Tubing
Rigid PVC Conduit, Schedule 40
Conductor Types THHN (Based on Table 1, Chapter 9)

	100%			80%			70%		
	1	2	3	4	5	6	7	8	9
6	1/2	1/2	3/4	3/4	1	1	1	1 1/4	1 1/4
4	1/2	3/4	1	1	1 1/4	1 1/4	1 1/4	1 1/4	1 1/2
2	1/2	1	1	1 1/4	1 1/4	1 1/2	1 1/2	1 1/2	2
1	1/2	1	1 1/4	1 1/4	1 1/2	1 1/2	2	2	2
1/0	1/2	1 1/4	1 1/4	1 1/2	1 1/2	2	2	2	2 1/2
2/0	3/4	1 1/4	1 1/4	1 1/2	2	2	2	2 1/2	2 1/2
3/0	3/4	1 1/4	1 1/2	2	2	2 1/2	2 1/2	2 1/2	3
4/0	3/4	1 1/2	1 1/2	2	2 1/2	2 1/2	3	3	3
250	1	2	2	2 1/2	2 1/2	3	3	3	3 1/2
300	1	2	2	2 1/2	3	3	3	3 1/2	3 1/2
350	1	2	2	2 1/2	3	3	3 1/2	3 1/2	4
400	1	2	2 1/2	3	3	3 1/2	3 1/2	4	4
500	1 1/4	2 1/2	2 1/2	3	3 1/2	3 1/2	4	4	5
600	1 1/4	2 1/2	3	3	3 1/2	4	5	5	5
700	1 1/4	3	3	3 1/2	4	5	5	5	5

750	1 ¼	3	3	3 ½	4	5	5	5	6
1000	1 ½	3	3 ½	4	5	5	6	6	6

4. Informative Annex D of NFPA 70 is adopted by reference without modification.
5. Informative Annex F of NFPA 70 is adopted by reference without modification.
6. Informative Annex G of NFPA 70 is adopted by reference without modification.
7. Informative Annex I of NFPA 70 is adopted by reference without modification.

**ARTICLE II.
OTHER APPLICABLE CODE AMENDMENTS**

SECTION 1. Section 1-4-090 of the Municipal Code of Chicago is hereby amended by deleting the language stricken through and by inserting the language underscored, as follows:

1-4-090 Definitions for Code provisions.

Unless the context requires other interpretations, the following words and terms are defined for purposes of this code as follows:

(Omitted text is unaffected by this ordinance)

(h) "Building code" or "building provisions of this Code" means: Titles 13 (excepting Chapter 13-72), 14E, and 18; Chapters 2-22, 7-4, 7-28; Article III of Chapter 11-4; Chapters 15-8, 15-12 and Article I of Chapter 15-16, Section 8-4-090; and all other provisions of this Code establishing or relating to construction, plumbing, heating, electrical, fire prevention, sanitation, zoning or other health and safety standards relating to structures (except to the extent authority for enforcement and administration is conferred exclusively on a department or agency other than the department of buildings or on an officer other than the building commissioner);

(i) "Electrical Code" or "electrical regulations of this Code" means ~~Chapter 18-27~~ Article II of Chapter 13-12 and Title 14E;

(Omitted text is unaffected by this ordinance)

SECTION 2. Section 2-120-060 of the Municipal Code of Chicago is hereby amended by deleting the language stricken through and by inserting the language underscored, as follows:

2-120-060 Powers and duties.

It shall be the duty of the said commission to formulate and recommend safe and practical standards and specifications for the installation, alteration and use of electrical equipment designed to meet the necessities and conditions that prevail in the City of Chicago, to recommend reasonable rules and regulations governing the issuance of electrical permits by ~~the electrical inspection section of the bureau of field inspections~~ and to recommend reasonable

fees to be paid for electrical inspections made by the electrical inspection section of the bureau of field inspections. The standards and specifications, rules and regulations governing the issuance of such permits and fees so recommended, shall become effective upon the passage of an ordinance adopting the same by the city council. All such fees shall be paid to the city comptroller. The commission may also hold hearings contesting the suspension, revocation or reinstatement of a license, certificate or registration issued pursuant to Chapters 4-290 and 4-292 Chapter 13-12 of this Code in the same manner as the procedure utilized by boards of examiners under Section 2-116-280 of this Code for license suspension or revocation and under Section 2-116-290 of this Code for license reinstatement.

SECTION 3. Section 4-75-150 of the Municipal Code of Chicago is hereby amended by deleting the language stricken through and by inserting the language underscored, as follows:

4-75-150 Night care privilege.

(Omitted text is unaffected by this ordinance)

(c) In addition to the other requirements for a children's service facility license, every applicant for a night care privilege shall comply with the following:

(Omitted text is unaffected by this ordinance)

(8) The emergency system and exit lighting system of the day care center shall comply with ~~Chapter 18-27~~ Title 14E of this Code;

(Omitted text is unaffected by this ordinance)

SECTION 4. Section 10-28-282 of the Municipal Code of Chicago is hereby amended by deleting the language stricken through and by inserting the language underscored, as follows:

10-28-282 Submission of plans.

No permit may be issued for an obstruction of the public way within the Central Business District caused by a heavy duty construction canopy unless the permit application is accompanied by the following:

(Omitted text is unaffected by this ordinance)

(c) Detailed drawings of all signs intended to be placed upon the construction canopy. The drawings shall indicate the size of the signs and must include a description of any advertisements on the signs. The description of the advertisements shall be reviewed solely for the purposes of determining compliance with paragraph (G) of Section 10-28-283. All drawings describing electrical signs shall also comply with Sections ~~18-27-600.27 and 18-27-600.28~~ 14E-6-600.27 and 14E-6-600.28.

SECTION 5. Section 13-8-140 of the Municipal Code of Chicago is hereby amended by deleting the language stricken through and by inserting the language underscored, as follows:

13-8-140 License, registration or certification – Suspension or revocation.

(Omitted text is unaffected by this ordinance)

(e) For purposes of this section:

“Person or entity licensed or registered, or required to be licensed or registered under this Code” includes, but is not limited to: ventilation contractors as limited business licensees (Chapter 4-4), refrigeration contractors as limited business licensees (Chapter 4-4), residential real estate developers (Article V of Chapter 4-6), expediter companies (Article XXV of Chapter 4-6), expeditors (Article XXVI of Chapter 4-6), general contractors (Chapter 4-36), excavators (Chapter 4-196), steam boiler erectors and repairers (Chapter 4-266), crane operators (Chapter 4-288), elevator mechanic contractors (Chapter 4-298), plumbers (Chapter 4-332), plumbing contractors (Chapter 4-336), stationary engineers and boiler tenders (Chapter 4-344), masons and mason contractors (Chapter 4-376), supervising electricians (Chapter 4-292), and electrical contractors (~~Article II of Chapter 13-12~~Chapter 4-290) and sign erectors and sign contractors (Article XIII of Chapter 13-20).

(Omitted text is unaffected by this ordinance)

SECTION 6. Section 13-8-150 of the Municipal Code of Chicago is hereby amended by deleting the language stricken through and by inserting the language underscored, as follows:

13-8-150 License, registration or certification – Suspension, revocation and reinstatement petition and hearing.

(Omitted text is unaffected by this ordinance)

(c) Petitions and hearings to contest the suspension or revocation of a license, registration or certification issued to any person pursuant to Chapter 4-4, Article II of Chapter 4-6, Article XXV of Chapter 4-6, Article XXVI of Chapter 4-6, Chapter 4-36, Chapter 4-196, Chapter 4-266, Chapter 4-290, Chapter 4-292, Chapter 4-298, ~~Article II of Chapter 13-12~~ and Article XII of Chapter 13-20 of this Code and revoked or suspended pursuant to Section 13-8-140 of this Code shall be as follows:

(Omitted text is unaffected by this ordinance)

(d) Petitions and hearings to reinstate a revoked license, registration or certification issued to a person pursuant to Chapter 4-4, Article II of Chapter 4-6, Article XXV of Chapter 4-6, Article XXVI of Chapter 4-6, Chapter 4-36, Chapter 4-196, Chapter 4-266, Chapter 4-290, Chapter 4-292, Chapter 4-298, ~~Article II of Chapter 13-12~~ and Article XII of Chapter 13-20 of this Code and revoked pursuant to Section 13-8-140 of this Code shall be as follows:

(Omitted text is unaffected by this ordinance)

SECTION 7. Section 13-12-160 of the Municipal Code of Chicago is hereby amended by deleting the language stricken through and by inserting the language underscored, as follows:

13-12-160 Space and access to be provided.

In every new building and in every existing building undergoing extensive remodeling where a new electrical service or a new electric distribution center is to be installed, ample space in conformance with ~~Article 18-27-110 of this Code~~ Section 14E-1-110 shall be provided ~~within the main walls of the building~~ for the electric service equipment, metering equipment, distribution cabinets, cutout cabinets, transformers and other equipment necessary for an electrical installation and ample working space around the said equipment. This space shall be readily accessible to every tenant of said building who has electric equipment for light, heat or power which is supplied through the above mentioned equipment.

(Omitted text is unaffected by this ordinance)

SECTION 8. Section 13-12-210 of the Municipal Code of Chicago is hereby amended by deleting the language stricken through and by inserting the language underscored, as follows:

13-12-210 Overfusing conductors or apparatus.

It shall be unlawful for any person to overfuse any conductor, motor, or apparatus in excess of the maximum allowed by the electrical regulations of this ~~chapter and Chapter 18-27 Code~~ Code for such conductor, motor, or apparatus, or to install any substitute in lieu of an approved overcurrent protective device so as to remove or reduce the factor of safety of the same.

SECTION 9. Article II, Part B, of Chapter 13-12 of the Municipal Code of Chicago, "Regulation of Electrical Contractors," is hereby repealed in its entirety.

SECTION 10. Title 4 of the Municipal Code of Chicago is hereby amended by inserting a new Chapter 4-290, as follows:

CHAPTER 4-290. ELECTRICAL CONTRACTORS

4-290-010 Registration required.

It shall be unlawful for any person to engage in the business of electrical contractor, as herein defined, without being registered as an electrical contractor in the manner hereinafter set forth.

4-290-020 Electrical contractor defined.

The term electrical contractor as used in this chapter, shall be understood to mean any person engaged in the business of installing, altering, or maintaining by contract electrical equipment for the utilization of electricity supplied for light, heat, power, signaling or communication not including radio apparatus or equipment for wireless reception of sounds and signals, conductors, and other equipment installed for or by public utilities including common carriers which are under the jurisdiction of the Illinois Commerce Commission, for use in their operation as public utilities; but the term electrical contractor does not include employees employed by such contractor to do or supervise such work.

4-290-030 Application and issuance of registration certificate.

Any person desiring to engage in the business of electrical contractor shall apply for registration to the building commissioner. Upon the filing of such application in proper form, and the payment of the registration fee as provided for in Section 4-290-050, the building commissioner shall register the applicant as an electrical contractor, and shall issue to the applicant a certificate of registration which will authorize the applicant to engage in such business during the period the registration is valid. Provided, however, that before any certificate of registration shall be issued to such applicant, the applicant shall have complied with Chapter 4-292.

4-290-040 Expiration of certificate.

The certificate of registration shall be valid for a period of one year from the date of issuance. A certificate of registration shall not be transferable and shall contain the name of the licensed supervising electrician.

4-290-050 Fee for registration.

The fee for registration as an electrical contractor shall be \$300.00, which sum shall be paid by the applicant to the department of finance in advance upon filing the application, and may be renewed upon payment of the required registration fee prior to or within three months of expiration of a valid registration. Any change in the information required in an application for registration shall require an additional registration. A fee as promulgated by rule of the commissioner shall be paid for each change of registration, including company name and ownership. A change of supervising electrician shall comply with 4-292-040 and be accompanied by a fee of \$100.00 which shall include the certification change fee in this section.

SECTION 11. Article II, Part C, of Chapter 13-12 of the Municipal Code of Chicago, "Supervising Electrician," is hereby repealed in its entirety.

SECTION 12. Title 4 of the Municipal Code of Chicago is hereby amended by inserting a new Chapter 4-292, as follows:

CHAPTER 4-292. SUPERVISING ELECTRICIANS

4-292-010 Appointment.

Before any certificate of registration shall be issued to any electrical contractor, entitled to secure permits under the electrical regulations of this Code, he shall appoint or employ a person who may be himself or some other person who, for the purpose of the electrical regulations of this Code, shall be known as a supervising electrician. The person so appointed or employed to act as a supervising electrician shall, before starting as such supervising electrician, be required to comply with Section 4-292-020.

4-292-020 Qualifications.

Applicants shall be not less than 21 years of age, and shall have had at least two years experience in the installation, alteration, repair, and maintenance of electrical wires, equipment, and apparatus, or an experience equivalent thereto. Such experience shall have been under the direct supervision of a supervising electrician, or the equivalent. Applicants shall furnish the names and addresses of former employers, periods of time employed by each and in what capacity. Such information and all other required relevant information shall be provided upon forms available from the department of buildings.

The department of buildings shall prepare as many different examinations as are necessary to adequately provide for the number of applicants in different specialties. Each applicant shall be required to pass an examination sufficiently strict to indicate that he has satisfactory knowledge and technical training to perform the work or to supervise the installation, alteration, repair, or maintenance of electrical wires and apparatus authorized by permits issued by the commissioner of the department of buildings. It shall be the responsibility of the commissioner to exercise control and supervision of such examinations.

(a) Each applicant shall pay an examination fee of \$150.00 for each examination the applicant takes. Such fee shall be paid to the department of finance prior to the day the examination is taken.

(b) Where the results of the first examination are unfavorable, the applicant shall be required to wait a period of six months before re-application.

4-292-030 Application for examination.

An applicant for a certificate of registration as a supervising electrician shall file an application with the commissioner of the department of buildings in writing on a form to be furnished by the department of buildings.

4-292-040 Certification and registration.

When an applicant shall have complied with the requirements of Section 4-290-010 and paid the appropriate fee, the commissioner of the department of buildings shall certify him as a supervising electrician to a registered electrical contractor by placing his name on both the registration certificate and identification card issued to the registered electrical contractor. No supervising electrician shall be certified with more than one registered electrical contractor or listed on more than one registration certificate. The fee for registration as a supervising electrician shall be \$300.00. The certificate of registration shall be valid for one year from the

date of issuance and may be renewed upon payment of the required license fee prior to or within three months of expiration of a valid license.

4-292-050 Duties.

The supervising electrician shall perform the work or supervise and direct the installation, alteration, repair, and maintenance of electrical equipment and apparatus authorized by permits issued under the authority of the electrical regulations of this Code. All applications for permits shall be signed by said supervising electrician.

4-292-060 Notice of discharge or resignation.

Whenever a supervising electrician shall leave or be discharged from the employ of any electrical contractor, who is required by this article to appoint or employ a supervising electrician, a written statement giving notice there of shall be provided within five days by both the employer and the supervising electrician to the building department, and the permit privileges of such electrical contractor, shall without further order or action by the building department stand suspended until the employment or appointment by such electrical contractor of a supervising electrician as provided for in Section 4-292-010.

A supervising electrician may transfer a valid registration to another electrical contractor with the permission of the licensing director, which permission shall not be unreasonably withheld. No supervising electrician shall be allowed to transfer more than twice during a 12-month period unless first serving a 90 day waiting period from the time of notice. The fee for all such a transfers shall be \$100.00.

4-292-070 Re-examination.

(a) Where a supervising electrician has not acted in the capacity of a supervising electrician in the city for a continuous period of three years, he shall be reexamined as provided for in Section 4-292-020 before he shall be certified as a supervising electrician.

(b) Where a supervising electrician has not obtained a permit from the department of buildings for a continuous period of three years he shall be required to take another examination as provided for in Section 4-292-020 before he shall receive another permit.

(c) Nothing in this section shall apply to any supervising electrician whose failure to act in that capacity or to obtain a permit for electrical work for a period of three years is due to the supervising electrician's having been employed by the City of Chicago during the period of such inactivity; provided, however, that if the former employee does not reapply for a license as a supervising electrician within 60 days after separation from City employment, the former employee shall be required to be reexamined for such license.

SECTION 13. Chapter 4-296 of the Municipal Code of Chicago, "Private Electric Light Companies," is hereby repealed in its entirety.

SECTION 14. Article II, Part D, of Chapter 13-12 of the Municipal Code of Chicago, "Registered Generator Operator," is hereby repealed in its entirety.

SECTION 15. Section 13-12-360 of the Municipal Code of Chicago is hereby amended by deleting the language stricken through and by inserting the language underscored, as follows:

13-12-360 Permits required.

No electrical equipment shall be installed or altered except upon a permit first issued by the department of buildings authorizing the installation, alteration, or repair of electrical equipment.

(a) If an electrical installation is commenced prior to the issuance of a permit for such work, the permit fee, for such work shall be twice the amount of the regular permit fee set forth in Section 13-32-310(b).

~~(b) Where a registered electrical contractor is found doing electrical work without a permit on three separate occasions in one calendar year, a hearing shall be held by the building commissioner at which time the permit privileges of said electrical contractor may be suspended for a period of time not to exceed one year.~~

(e)(b) When contracts to install electrical work have been obtained by persons who are not registered as electrical contractors, as provided for in this article and the contract is assigned or sublet to a registered electrical contractor on a subcontract basis, the name of such registered electrical contractor shall immediately be disclosed by the registered electrical contractor to the other party to the contract in writing.

SECTION 16. Section 13-12-375 of the Municipal Code of Chicago is hereby repealed in its entirety.

SECTION 17. Section 13-12-380 of the Municipal Code of Chicago is hereby amended by deleting the language stricken through and by inserting the language underscored, as follows:

13-12-380 Inspection.

The building commissioner shall inspect or shall cause to be inspected all electrical equipment installed or altered, except such electrical equipment as may be lawfully exempt, and shall require that it conform to the electrical regulations of this ~~chapter and Chapter 18-27~~ Code.

SECTION 18. Section 13-12-390 of the Municipal Code of Chicago is hereby deleted in its entirety:

13-12-390 Certificate of inspection.

~~Upon completion of such installation or alteration in compliance with the electrical regulations of this chapter and Chapter 18-27, the building commissioner shall, on request made by a registered electrical contractor, issue a certificate of inspection covering such installation or alteration; provided, however, that no such certificate shall be issued until all inspection fees for such installation have been paid.~~

SECTION 19. Section 13-12-400 of the Municipal Code of Chicago is hereby amended by deleting the language stricken through and by inserting the language underscored, as follows:

13-12-400 Reinspection.

The building commissioner or electrical inspectors are hereby empowered to reinspect any electrical equipment within the scope of the electrical regulations of this ~~chapter and Chapter 18-27~~ Code, and when said electrical equipment is found to be unsafe to life or property, shall notify in writing either the owner, his agent for the purpose of managing, controlling or collecting rents or any other person managing, controlling, using or operating the same to place such electrical equipment in a safe and secure condition in compliance with the electrical regulations of this ~~chapter and Chapter 18-27~~ Code within such time as the building commissioner shall consider just and reasonable, but in no event shall this time exceed 15 days from the date of such notice. Refusal to comply with the requirements of such notice shall subject the person owning, managing, operating or using such electrical equipment to the penalties provided for in Section 13-12-040 ~~of this article~~. The building commissioner is hereby empowered to cut off and stop current to any electrical equipment found to be unsafe to life or property.

SECTION 20. Section 13-12-410 of the Municipal Code of Chicago is hereby amended by deleting the language stricken through and by inserting the language underscored, as follows:

13-12-410 Record of permits.

The department of buildings shall keep complete records of all permits issued and inspections made and other official work performed under the electrical regulations of this ~~chapter and Chapter 18-27~~ Code.

SECTION 21. Section 13-12-460 of the Municipal Code of Chicago is hereby amended by deleting the language stricken through and by inserting the language underscored, as follows:

13-12-460 Permit for person not entitled to one.

It shall be unlawful for any registered electrical contractor to secure or furnish a permit for the installation, alteration, and repair of electrical wires and apparatus to any person not entitled to such permit under the electrical regulations of this ~~electrical chapter and Chapter 18-27 Code.~~

SECTION 22. Article II, Part H, of Chapter 13-12 of the Municipal Code of Chicago, "Commercial Electric Lamp Posts," is hereby repealed in its entirety.

SECTION 23. Article II, Part I, of Chapter 13-12 of the Municipal Code of Chicago, "Festoons and Decorative Street Lighting Equipment," is hereby repealed in its entirety.

SECTION 24. Section 13-12-890 of the Municipal Code of Chicago is hereby amended by deleting the language stricken through and by inserting the language underscored, as follows:

13-12-890 Penalty

Any person who violates any of the provisions of this article, or who maintains any electrical wiring and apparatus found to be dangerous to life and property, shall be fined ~~not more than~~ \$500.00 for each offense. Each day such violation shall continue shall constitute a separate and distinct offence, and so much of any electrical installation as may be erected or altered and maintained in violation of this article or of ~~Chapter 18-27 Title 14E of this Code~~ shall be condemned and the building commissioner is hereby empowered to cut off and discontinue current to such electrical wires and apparatus.

SECTION 25. Section 13-20-420 of the Municipal Code of Chicago is hereby amended by deleting the language stricken through and by inserting the language underscored, as follows:

13-20-420 Extra inspections.

Except as otherwise provided in this code, a fee of ~~\$75.00~~ \$100.00 per hour or fraction of an hour shall be assessed, per inspector, for (1) any inspection of electrical work unrelated to the issuance of a permit under Chapter 13-32; or (2) any inspection of electrical work related to the issuance of a permit under Chapter 13-32, if an extra inspection of such electrical work is: (i) specially requested by any owner, general contractor or subcontractor identified on the permit application; or (ii) required due to inaccurate or incorrect information on the permit application, or faulty construction or installation, or the failure to make necessary repairs. Provided, however, that a minimum inspection fee of ~~\$75.00~~ \$250.00 shall be required.

SECTION 26. Section 13-20-500 of the Municipal Code of Chicago is hereby amended by deleting the language stricken through and by inserting the language underscored, as follows:

13-20-500 Scope.

This article covers the requirements for approval of applications, issuance of permits, and supervision of all signs, signboards, and supporting structures, as defined below, which are constructed, erected, or being maintained under the provisions of this chapter.

The installation requirements for this equipment are covered in ~~Article 600 of Chapter 18-27~~ Section 14E-6-600.

SECTION 27. Section 13-20-570 of the Municipal Code of Chicago is hereby amended by deleting the language stricken through and by inserting the language underscored, as follows:

13-20-570 Drawings.

All required drawings shall comply with ~~Sections 18-27-600.27 and 18-27-600.28~~ 14E-6-600.27 and 14E-6-600.28. Engineered drawings shall bear the architects or engineers name, address, and business telephone number.

SECTION 28. Section 13-20-700 of the Municipal Code of Chicago is hereby amended by deleting the language stricken through and by inserting the language underscored, as follows:

13-20-700 Posting of bonds.

(Omitted text is unaffected by this ordinance)

(b) *Annual bond.* An individual annual \$15,000.00 bond for each sign shall be required on subsections (8) and (9) of Section 18-27-600.28 14E-6-600.28. (Roof signs and pole signs over 24 feet ~~(610 mm)~~ in height.) In lieu of such individual annual bond, any person, firm, or corporation owning, leasing, erecting, maintaining, or removing any sign or signs within the description of these subsections may file with the buildings commissioner proof of insurance issued by any casualty company authorized to insure in the State of Illinois which shall name the City of Chicago and its officials, agents, or servants as additional insured on a primary, noncontributory basis for any liability arising directly or indirectly from the permittee's operations and for any and all claims, demands, or suits for personal injury or property damage where the liability alleged against the City of Chicago for such injury or property damage arises out of the provisions of this Article XIII. Such proof of commercial general liability insurance shall be in an amount not less than \$300,000.00 per occurrence for bodily injury, with bodily injury limits of not less than \$100,000.00 per person and \$300,000.00 per accident for personal injury and property damage, and shall further provide that the building commissioner be given 30 days' advance notice by the insurer prior to any cancellation of or lapse in the coverage.

SECTION 29. Section 13-20-720 of the Municipal Code of Chicago is hereby amended by deleting the language stricken through and by inserting the language underscored, as follows:

13-20-720 General restrictions.

No person, firm, or corporation shall place on or suspend from any building, sign, structure, canopy, lot, or place any goods, wares, merchandise, or any other material not in conformance with ~~Article 600 of Chapter 18-27~~ Section 14E-6-600 and this article.

SECTION 30. Section 13-20-730 of the Municipal Code of Chicago is hereby amended by deleting the language stricken through and by inserting the language underscored, as follows:

13-20-730 Notice of non-compliance.

Whenever it shall appear to the building commissioner that any such sign or structure has been erected in violation of the provisions of this chapter or is in an unsafe condition or has become unstable or insecure, or is in such a condition as to be a menace to the safety or health of the public, he shall thereupon issue or cause to be issued a notice in writing to the owner of such sign or structure, or person in charge, possession, or control thereof, if the whereabouts of such person is known, informing such person of the violation of the provisions of this chapter or of the dangerous condition of such sign or structure and directing him to make such alteration or repairs thereto as shall be necessary to make the same comply with the requirements of this chapter and ~~Chapter 18-27 Title 14E of this Code~~ within such reasonable time as may be stated in said notice. If the necessary alterations and repairs are not made within the time period specified, the permit for the sign or structure will be revoked by the building commissioner without further notice. The written notice required by this section shall so inform the person to whom the notice is directed.

SECTION 31. Section 13-20-740 of the Municipal Code of Chicago is hereby amended by deleting the language stricken through and by inserting the language underscored, as follows:

13-20-740 Posting non-compliance notice.

If the owner of such sign or structure or the person in possession, charge, or control thereof cannot be found or his whereabouts cannot be ascertained, the building commissioner shall attach or cause to be attached to said sign or structure a notice of the same import as that required to be sent to the owner or person in possession, charge, or control thereof when the owner is known; and if such sign or structure shall not have been made to conform to the provisions of this chapter and placed in a secure, safe, and substantial condition in accordance with the requirements of such notice within 30 days after such notice shall have been attached to such sign or structure, the building commissioner may thereupon cause such sign or structure or such portion thereof as is constructed and maintained in violation of the provisions of this

chapter or ~~Chapter 18-27~~, Title 14E of this Code to be torn down; provided however, that nothing herein contained shall prevent the building commissioner from adopting such precautionary measures as may be necessary or advisable in case of imminent danger in order to place such sign or structure in a safe condition, the expense of which shall be charged to and recovered from the owner of such sign or structure, or the person in charge, possession, or control thereof, in any appropriate proceedings therefore. If the necessary alterations and repairs are not made within the time period specified, the permit for the sign or structure will be revoked by the building commissioner without further notice. The written notice required by this section shall so inform the person to whom the notice is directed.

SECTION 32. Section 13-20-770 of the Municipal Code of Chicago is hereby amended by deleting the language stricken through and by inserting the language underscored, as follows:

13-20-770 Removal of sign or structure.

It shall be the duty of the building commissioner to remove or cause the removal of any sign or structure not in compliance with any of the provisions of this article and ~~Article 18-27-600~~ Section 14E-6-600 dealing with signs, and any compensation or inspection fees paid to the City of Chicago for such sign shall not be refunded. The owner of such sign shall be held liable for all expenses incurred by the building department in the performance of this duty to remove.

SECTION 33. Section 13-24-040 of the Municipal Code of Chicago is hereby amended by deleting the language stricken through, as follows:

13-24-040 Limitation of board of appeals jurisdiction.

(Omitted text is unaffected by this ordinance)

Further, the board shall not have jurisdiction over matters pertaining to the electrical regulations of the Municipal Code ~~municipal code~~, specifically ~~Chapter 18-27~~ as defined in ~~Section 1-4-090(i)~~.

SECTION 34. Section 13-64-010 of the Municipal Code of Chicago is hereby amended by deleting the language stricken through and by inserting the language underscored, as follows:

13-64-010 General requirements.

Every building or part of a building hereafter designed, erected, altered or converted for the purposes of a residential unit as defined in Section 13-56-020 shall comply with the special provisions of this chapter and also with the general provisions of this Code pertaining to buildings, including, but not limited to, the following:

(Omitted text is unaffected by this ordinance)

~~Chapters 4-332, 13-168 and 18-29~~ Plumbing.

Chapter 18-29 Sanitation Requirements.

~~Chapter 18-27~~ Title 14E Electrical Requirements.

SECTION 35. Section 13-68-010 of the Municipal Code of Chicago is hereby amended by deleting the language stricken through and by inserting the language underscored, as follows:

13-68-010 General requirements.

Every building or part of a building hereafter designed, erected, altered or converted for the purpose of a business unit as defined in Section 13-56-120 shall comply with the special provisions of this chapter and also with the general provisions of this Code pertaining to buildings, including, but not limited, to the following:

(Omitted text is unaffected by this ordinance)

~~Chapters 4-332, 13-168 and 18-29~~ Plumbing.

Chapter 18-29 Sanitation Requirements.

~~Chapter 18-27~~ Title 14E Electrical Requirements.

(Omitted text is unaffected by this ordinance)

SECTION 36. Section 13-76-080 of the Municipal Code of Chicago is hereby amended by deleting the language stricken through and by inserting the language underscored, as follows:

13-76-080 Emergency electrical systems.

Emergency electrical systems shall be provided in buildings as follows:

(a) All buildings included in this chapter shall be supplied by a System 2 emergency system that shall supply the elevator required by Section 13-76-130 of this Code, all emergency and exit lights, the communication systems required by Section 13-76-050 of this Code, the fire command panel required by Section 13-76-030 of this Code, and the fire alarm system required by Section 13-76-040 of this Code. The System 2 emergency system shall conform with all applicable provisions of ~~Chapter 18-27 of this Code~~ Title 14E of this Code.

(Omitted text is unaffected by this ordinance)

(g) All existing and newly constructed buildings used in whole or in part for residential occupancy which are more than 80 feet above grade, shall provide an auxiliary source of current supply from either an approved, on-site generator in accordance with ~~Chapter 18-27~~ Title 14E, an approved central battery system, or approved unit battery fixtures in accordance

with ~~Chapter 18-27~~ Title 14E of this Code to supply all required emergency lights throughout the building. The fuel source for on-site generators installed in buildings over 80 feet in height and under 400 feet in height may be natural gas or diesel fuel. The fuel for on-site generators installed in buildings over 400 feet in height shall be diesel, in accordance with the provisions of Section 13-76-080(b) of this Code. ~~Two complete sets of Complete~~ plans shall be submitted to the ~~Bureau of Electrical Inspection~~ department of buildings for review and approval before any work is started on the installation of such systems. All buildings which conform to the requirements of this section at the time this section is enacted shall not be required to provide plans as required herein. All buildings required by this chapter to provide an auxiliary source of current supply for required emergency lighting shall comply no later than July 1, 1999.

SECTION 37. Section 13-80-010 of the Municipal Code of Chicago is hereby amended by deleting the language stricken through and by inserting the language underscored, as follows:

13-80-010 General requirements.

Every building or part of a building hereafter designed, erected, altered or converted for the purposes of an institutional unit as defined in Section 13-56-050 shall comply with the special provisions of this chapter and also with the general provisions of this Code pertaining to buildings, including, but not limited to the following:

(Omitted text is unaffected by this ordinance)

~~Chapters 4-332, 13-168 and 18-29~~ Plumbing.

Chapter 18-29 Sanitation Requirements.

~~Chapter 18-27~~ Title 14E Electrical Requirements.

(Omitted text is unaffected by this ordinance)

SECTION 38. Section 13-80-040 of the Municipal Code of Chicago is hereby repealed in its entirety.

SECTION 39. Section 13-84-010 of the Municipal Code of Chicago is hereby amended by deleting the language stricken through and by inserting the language underscored, as follows:

13-84-010 General requirements.

Every building or part of a building hereafter designed, erected, altered or converted for the purposes of an assembly unit as defined in Section 13-56-070 shall comply with the special provisions of this chapter and also with the general provisions of this Code pertaining to buildings, including, but not limited to, the following:

(Omitted text is unaffected by this ordinance)

~~Chapters 4-332, 13-168 and 18-29~~ Plumbing.

~~Chapter 18-28~~ 18-29 Sanitation Requirements.

~~Chapter 18-27~~ Title 14E Electrical Requirements.

(Omitted text is unaffected by this ordinance)

SECTION 40. Section 13-84-080 of the Municipal Code of Chicago is hereby amended by deleting the language stricken through and by inserting the language underscored, as follows:

13-84-080 Construction requirements – Type 1 stages.

Type 1 stages shall comply with the following construction requirements:

(Omitted text is unaffected by this ordinance)

(g) Protection of Electrical Equipment. All electrical equipment shall be protected from falling objects and from contact with stage equipment, and shall conform with the electrical requirements of ~~Chapter 18-27~~ Title 14E.

(Omitted text is unaffected by this ordinance)

SECTION 41. Section 13-84-100 of the Municipal Code of Chicago is hereby amended by deleting the language stricken through and by inserting the language underscored, as follows:

13-84-100 Stage vents – Type 1 stages.

Every Type 1 stage shall be provided with a means of natural ventilation so arranged and equipped as to function in case of fire. Such means of ventilation shall consist of not less than one vent nor more than three vents to the outer air meeting the requirements of this section.

(Omitted text is unaffected by this ordinance)

(e) *Dampers.* All stage vents shall also be equipped with damper controls as required by ~~Chapter 18-27~~ 18-28 of this Code.

(Omitted text is unaffected by this ordinance)

SECTION 42. Section 13-84-120 of the Municipal Code of Chicago is hereby amended by deleting the language stricken through and by inserting the language underscored, as follows:

13-84-120 Projection rooms.

(Omitted text is unaffected by this ordinance)

(c) ~~Room Area and Ceiling Height for Dual Projection Booths.~~ Room area and ceiling height of projection rooms shall be as provided in Chapter 18-27 of this Code: [Reserved.]

(Omitted text is unaffected by this ordinance)

SECTION 43. Section 13-88-010 of the Municipal Code of Chicago is hereby amended by deleting the language stricken through and by inserting the language underscored, as follows:

13-88-010 General requirements.

Every building or part of a building hereafter designed, erected, altered or converted for the purposes of an open air assembly unit as defined in Section 13-56-110 shall comply with the special provisions of this chapter and also with the general provisions of this Code pertaining to buildings, including, but not limited to, the following:

(Omitted text is unaffected by this ordinance)

~~Chapters 4-332, 13-168* and 18-29~~ Plumbing.

Chapter 18-29 Sanitation Requirements.

~~Chapter 18-27~~ Title 14E Electrical Requirements.

(Omitted text is unaffected by this ordinance)

SECTION 44. Section 13-96-070 of the Municipal Code of Chicago is hereby amended by deleting the language stricken through and by inserting the language underscored, as follows:

13-96-070 Height and location limitations.

(Omitted text is unaffected by this ordinance)

(d) *Projecting Signs.* The height of a projecting sign shall not exceed 70 feet, and the area of one face of a projecting sign shall not exceed 250 square feet. Signs projecting over public property shall be in accordance with requirements of ~~Chapter 18-27 of this Code~~ Section 14E-6-600.

(Omitted text is unaffected by this ordinance)

SECTION 45. Section 13-96-090 of the Municipal Code of Chicago is hereby amended by deleting the language stricken through and by inserting the language underscored, as follows:

13-96-090 General requirements.

Electric signs and signboards shall comply with the provisions of ~~Chapter 18-27~~ Title 14E of this Code.

SECTION 46. Section 13-96-490 of the Municipal Code of Chicago is hereby amended by deleting the language stricken through and by inserting the language underscored, as follows:

13-96-490 Assembly occupancy.

(Omitted text is unaffected by this ordinance)

(f) Permits for all electrical wiring shall be secured in accordance with the provisions electrical regulations of ~~Chapter 18-27~~ of this Code.

(g) Exit and emergency lighting shall be provided for all tents exceeding 600 square feet in area that will be in use for 48 hours or longer or have interior partitions. Such tents shall be provided with the appropriate emergency lighting system, as described in ~~Chapter 18-27~~ of this Code Section 14E-7-700. Exit and emergency plans for tents and canopies exceeding 600 square feet in area shall be provided for review by the fire commissioner and electrical inspection bureau, and shall be approved prior to occupancy and use of the tent or canopy structure.

(Omitted text is unaffected by this ordinance)

SECTION 47. Section 13-96-780 of the Municipal Code of Chicago is hereby amended by deleting the language stricken through and by inserting the language underscored, as follows:

13-96-780 Electrical requirements.

(a) All electrical installations provided for, installed and used in conjunction with private residential swimming pools, shall be in conformance with ~~18-27~~ Title 14E of this Code.

(b) ~~No current carrying electrical conductors shall cross private residential swimming pools, either overhead or underground or within 15 feet of such pools.~~

(c) ~~All metal fences, enclosures or railings near or adjacent to private residential swimming pools, which might become electrically alive as a result of contact with broken overhead conductors, or from any other cause, shall be effectively grounded.~~

SECTION 48. Section 13-96-940 of the Municipal Code of Chicago is hereby amended by deleting the language stricken through and by inserting the language underscored, as follows:

13-96-940 Emergency lighting.

Emergency lighting shall comply with System III as defined in ~~Chapter 18-27~~ Section 14E-7-700.

SECTION 49. Section 13-96-1230 of the Municipal Code of Chicago is hereby amended by deleting the language stricken through and by inserting the language underscored, as follows:

13-96-1230 Electrical requirements.

(a) Every shooting range facility shall be constructed with a type II (battery pack) emergency lighting in conformance with the requirements of ~~Article 700 of Chapter 18-27~~ Section 14E-7-700.

(Omitted text is unaffected by this ordinance)

SECTION 50. Section 13-100-010 of the Municipal Code of Chicago is hereby amended by deleting the language stricken through and by inserting the language underscored, as follows:

13-100-010 General requirements.

Every building or part of a building hereafter designed, erected, altered or converted for the purposes of a mercantile unit as defined in Section 13-56-130 shall comply with the special provisions of this chapter and also with the general provisions of this Code pertaining to buildings, including, but not limited to, the following:

~~Chapters 4-332, 13-168 and 18-29~~ Plumbing.

Chapter 18-29 Sanitation Requirements.

~~Chapter 18-27~~ Title 14E Electrical Requirements.

(Omitted text is unaffected by this ordinance)

SECTION 51. Section 13-104-010 of the Municipal Code of Chicago is hereby amended by deleting the language stricken through and by inserting the language underscored, as follows:

13-104-010 General requirements.

Every building or part of a building hereafter designed, erected, altered or converted for the purposes of an industrial unit as defined in Section 13-56-140 shall comply with the special provisions of this chapter and also with the general provisions of this Code pertaining to buildings, including, but not limited to, the following:

(Omitted text is unaffected by this ordinance)

Chapter ~~18-298~~ 18-28 Heating.

Chapter ~~18-298~~ 18-28 Ventilation.

(Omitted text is unaffected by this ordinance)

Chapters ~~4-332, 13-168~~ and 18-29 Plumbing.

Chapter 18-29 Sanitation Requirements.

Chapter ~~18-27~~ Title 14E Electrical Requirements.

(Omitted text is unaffected by this ordinance)

SECTION 52. Section 13-108-010 of the Municipal Code of Chicago is hereby amended by deleting the language stricken through and by inserting the language underscored, as follows:

13-108-010 General requirements.

Every building or part of a building hereafter designed, erected, altered or converted for the purposes of a storage unit as defined in Section 13-56-170 shall comply with the special provisions of this chapter and also with the general provisions of this Code pertaining to buildings, including, but not limited to, the following:

(Omitted text is unaffected by this ordinance)

Chapters ~~4-332, 13-168~~ and 18-29 Plumbing.

Chapter 18-29 Sanitation Requirements.

Chapter ~~18-27~~ Title 14E Electrical Requirements.

(Omitted text is unaffected by this ordinance)

SECTION 53. Section 13-112-010 of the Municipal Code of Chicago is hereby amended by deleting the language stricken through and by inserting the language underscored, as follows:

13-112-010 General requirements.

Every building, structure or tank, or part of a building, hereafter designed, erected, altered or converted for the purposes of a hazardous use unit, as defined in Section 13-56-210, shall comply with the building provisions of this Code, including, but not limited to, the following:

(Omitted text is unaffected by this ordinance)

Chapter ~~13-156~~ 18-30 Elevators.

(Omitted text is unaffected by this ordinance)

Chapters ~~4-332, 13-168 and 18-29~~ Plumbing.

Chapter 18-29 Sanitation Requirements.

Chapter ~~18-27~~ Title 14E Electrical Requirements.

(Omitted text is unaffected by this ordinance)

SECTION 54. Section 13-160-269 of the Municipal Code of Chicago is hereby amended by inserting the language underscored, as follows:

13-160-269 Electromagnetic locking devices.

(Omitted text is unaffected by this ordinance)

(d) *Electrical Requirements.* Wiring for electromagnetic locking devices shall not occupy the same raceways or enclosures as wiring for required life safety systems, including required fire detection systems and exit/emergency lighting and power systems. Wiring for electromagnetic locking devices may occupy the same raceways and enclosures as "normal" lighting and power systems within a building, or may be installed in separate, dedicated raceways and enclosures. In addition to the requirements of this section, all electrical wiring and equipment installations shall conform to the requirements provided in Title 14E of this Code.

(Omitted text is unaffected by this ordinance)

SECTION 55. Section 13-160-730 of the Municipal Code of Chicago is hereby amended by deleting the language stricken through and by inserting the language underscored, as follows:

13-160-730 Directional signs – Illumination.

Every such sign shall be internally illuminated by a light source providing light intensity at the face of the sign equal to or greater than that provided by a ten watt or larger incandescent electric lamp.

SECTION 56. Section 13-160-690 of the Municipal Code of Chicago is hereby amended by deleting the language stricken through and by inserting the language underscored, as follows:

13-160-690 Emergency lighting.

Emergency lighting shall be provided in accordance with the requirements of Chapter ~~18-27 of this Code~~ Section 14E-7-700.

SECTION 57. Section 13-160-760 of the Municipal Code of Chicago is hereby amended by deleting the language stricken through and by inserting the language underscored, as follows:

13-160-760 Directional signs – Phosphorescent signs.

Exit, stairway, fire escape and directional signs of luminous phosphorescent material illuminated as herein before required may be used in lieu of requirements of Systems II and III, as defined in Sections 14E-7-700 ~~14-48-060 and 14-48-070~~ of the Municipal Code of Chicago, in all existing buildings and in buildings hereafter erected, altered, or converted, ~~in accordance with Section 14-48-030*~~ of the Municipal Code of Chicago.

(Omitted text is unaffected by this ordinance)

SECTION 58. Section 13-200-320 of the Municipal Code of Chicago is hereby amended by deleting the language stricken through and by inserting the language underscored, as follows:

(Omitted text is unaffected by this ordinance)

13-200-320 Assembly occupancy alterations.

Any stage or projection block hereafter altered or remodeled shall comply in its entirety with the provisions of this Code for new construction:

(Omitted text is unaffected by this ordinance)

(h) Emergency electrical systems and lighting shall be provided, in accordance with the requirements of Chapter ~~18-27~~ Section 14E-7-700.

SECTION 59. Section 13-200-470 of the Municipal Code of Chicago is hereby amended by deleting the language stricken through and by inserting the language underscored, as follows:

13-200-470 Electrical requirements.

When alterations, remodeling or repairs being made pursuant to the provisions of this chapter encompass 60 percent or more of a building structure, dwelling unit or electrical system, then, the wiring serving such building or dwelling unit shall conform to the provisions of Section 14E-5-560 Title 14 as they apply to new construction requirements for dwelling type occupancies, such provisions are more fully set forth in Chapter 18-27.

SECTION 60. Section 13-200-480 of the Municipal Code of Chicago is hereby amended by deleting the language stricken through and by inserting the language underscored, as follows:

13-200-480 Alteration, remodeling or repairs less than 60 percent of structure – Wiring standards.

When alterations, remodeling or repairs being made pursuant to the provisions of this chapter encompass less than 60 percent of a building structure, dwelling unit or electrical system in an existing residential building not exceeding four stories in height or in the residential portion of an existing building of mixed occupancy not exceeding four stories in height, then, the wiring serving such building or dwelling unit shall conform to the minimum standards as set forth in ~~Chapter 18-27~~ Section 14E-5-570.

SECTION 61. Section 15-16-1200 of the Municipal Code of Chicago is hereby amended by deleting the language stricken through and by inserting the language underscored, as follows:

(Omitted text is unaffected by this ordinance)

15-16-1200 Definition of system.

The words "standard fire alarm system" where used in this Code, are hereby defined to mean a manually operated fire alarm system equipped with automatic detectors, if required, as hereinafter defined. Such system shall be installed in a building for the purpose of notifying the occupants and/or employees of said building of conditions due to fire or other causes which necessitate that the building be vacated immediately by the occupants. All equipment and devices used in the installation of such a system shall be tested by and bear the label of approval of a nationally recognized testing laboratory acceptable to the fire commissioner and the bureau of electrical inspection. The workmanship, equipment and quality of installation shall conform to ~~the electrical requirements of Title 14E of the Municipal~~ this Code.

SECTION 62. Section 15-16-1510 of the Municipal Code of Chicago is hereby amended by deleting the language stricken through and by inserting the language underscored, as follows:

15-16-1510 Approval of plans.

Before any work is started on the installation, alteration or extension of any fire alarm system, required by Article I of Chapter 15-16 of this Code, complete plans and specifications of the proposed installation shall be submitted to the ~~bureau of fire prevention and to the~~ department of buildings for examination and approval. All installations, alterations or extensions of such fire alarm systems shall comply with all of the provisions of ~~Chapter 18-27~~ Title 14E of this Code. The provisions of Sections 15-16-1200 to 15-16-1510, both inclusive, shall apply to existing buildings including preordinance buildings and buildings hereafter constructed.

SECTION 63. Section 15-24-060 of the Municipal Code of Chicago is hereby amended by inserting the language underscored, as follows:

15-24-060 Heating.

Heating in rooms and buildings used for the storage and handling of Class I flammable liquids shall be by steam, hot water or approved electrical heaters installed in accordance with Title 14E of this Code. Fire walls shall surround all boilerrooms, furnace rooms and other rooms containing exposed fire, electric dynamos, motors, switches or other spark-producing devices.

SECTION 64. Section 15-24-620 of the Municipal Code of Chicago is hereby amended by deleting the language stricken through and by inserting the language underscored, as follows:

15-24-620 Restrictions around spray booths.

(Omitted text is unaffected by this ordinance)

(d) Electrical wiring and equipment not subject to deposits of combustible residues but located in a spray area shall be of the explosion-proof type approved for use in such hazardous locations. Such area shall be considered a Class I Division 1 hazardous location as defined in Title Section 14E-5-500.

(e) Electrical wiring, motors and other equipment outside of but within 20 feet of any spray area and not separated, as directed in Section 15-24-570, shall not produce sparks under normal operating conditions. Such area shall be considered as Class I Division 2 hazardous locations as Title Section 14E-5-500.

(Omitted text is unaffected by this ordinance)

(g) Portable electric lamps shall not be used in any spray area during spraying operations. Portable electric lamps used during cleaning or repairing operations shall be of the type specifically approved for Class I hazardous locations as defined in Title Section 14E-5-500.

(Omitted text is unaffected by this ordinance)

SECTION 65. Section 15-24-680 of the Municipal Code of Chicago is hereby amended by deleting the language stricken through and by inserting the language underscored, as follows:

15-24-680 Electrostatic paint-spraying apparatus.

(Omitted text is unaffected by this ordinance)

(b) Transformers, power packs, control apparatus and all other electrical portions of the equipment, with the exception of high voltage grids and electrostatic atomizing heads and their connections, shall be located outside of the spraying areas or vapor areas as defined in Section 15-24-550 or shall comply with the requirements of Title Section 14E-5-500 ~~of~~ for Class II hazardous locations.

(Omitted text is unaffected by this ordinance)

SECTION 66. Section 15-24-690 of the Municipal Code of Chicago is hereby amended by deleting the language stricken through and by inserting the language underscored, as follows:

15-24-690 Electrical equipment.

All electrostatic paint spray apparatus shall conform to the requirements of Title 14E ~~of this Code~~ and with the following specific requirements:

(Omitted text is unaffected by this ordinance)

SECTION 67. Section 15-24-710 of the Municipal Code of Chicago is hereby amended by deleting the language stricken through and by inserting the language underscored, as follows:

15-24-710 Portable electrostatic paint-spraying operations.

(Omitted text is unaffected by this ordinance)

(b) Transformers, power packs, control apparatus and all other electrical portions of the equipment, with the exception of electrostatic atomizing spray gun and its connections, shall be located outside of the spraying areas or vapor areas, as defined in Section 15-24-550 or shall comply with the requirements of Title Section 14E-5-500 ~~of~~ for Class II hazardous locations.

(Omitted text is unaffected by this ordinance)

SECTION 68. Section 15-24-770 of the Municipal Code of Chicago is hereby amended by deleting the language stricken through and by inserting the language underscored, as follows:

15-24-770 Electrical equipment.

Electrical wiring, motors and fixtures in any dip tank vapor area shall comply with Title 14E for hazardous locations and with the specific provisions of this section.

(Omitted text is unaffected by this ordinance)

(b) Electric wiring and equipment in any dip tank vapor area shall be explosion-proof type approved for use in such hazardous locations. Such area shall be considered as Class I, Division 1 hazardous locations as defined in Title Section 14E-5-500 of this Code.

(Omitted text is unaffected by this ordinance)

(d) In any floor space outside of the dip tank vapor area, but within 20 feet therefrom and not separated by fire separation complying with Section 15-24-730, there shall be no open flames or spark-producing devices. Such areas shall be considered as Class I, Division 2 hazardous locations as defined in Title Section 14E-5-500.

SECTION 69. Section 15-24-830 of the Municipal Code of Chicago is hereby amended by inserting the language underscored, as follows:

15-24-830 Roll coating operations.

(Omitted text is unaffected by this ordinance)

(b) Adequate arrangements shall be made to prevent sparks from static electricity by electrically bonding and grounding all metallic rotating and other parts of the machinery and equipment and by the installation of static collectors. All such electrical bonding and grounding shall be done in strict accordance with the provisions of Title 14E of this Code.

SECTION 70. Section 15-24-860 of the Municipal Code of Chicago is hereby amended by deleting the language stricken through and by inserting the language underscored, as follows:

15-24-860 Fire prevention requirements.

(Omitted text is unaffected by this ordinance)

(c) Motor vehicles refinishing booths or enclosures, otherwise installed and maintained in conformity with this section, may alternately be used for drying with portable infrared drying apparatus when complying with the following:

(Omitted text is unaffected by this ordinance)

5. All electrical wiring and equipment of the drying apparatus shall conform to Title 14E of this Code. Only equipment of a type approved for Class I, Division 2 hazardous locations, as defined in Title Section 14E-5-500, shall be located within 18 inches of the floor level. All metallic parts of the drying apparatus shall be properly electrically bonded and grounded.

SECTION 71. Section 15-28-350 of the Municipal Code of Chicago is hereby amended by inserting the language underscored, as follows:

15-28-350 Fire prevention requirements.

The storage and handling of organic peroxides shall comply with the following provisions:

(Omitted text is unaffected by this ordinance)

(8) All processing equipment shall be properly grounded in conformity with Title 14E of this Code. Conductive and spark-resistant floors shall be provided in all manufacturing areas where organic peroxides are used. Conductive safety shoes shall be worn by all operating personnel. All scoops used for weighing the material shall be made of nonsparking materials.

(Omitted text is unaffected by this ordinance)

(13) Only wiring complying with the requirements of Title 14E of this Code shall be permitted. All electric lights shall be protected with suitable guards.

(Omitted text is unaffected by this ordinance)

SECTION 72. Section 15-28-1210 of the Municipal Code of Chicago is hereby amended by inserting the language underscored, as follows:

15-28-1210 Dust collection system.

(Omitted text is unaffected by this ordinance)

2. *Exhaust System Design Requirements.*

(Omitted text is unaffected by this ordinance)

(m) (1). *Materials of Construction.* All pipes shall be constructed of not less than the following gauges of metal, or other noncombustible and moisture-resisting material of equivalent strength:

(Omitted text is unaffected by this ordinance)

6. *Electrical Controls.* All electrical controls shall be installed as provided in Title 14E of this Code.

SECTION 73. Section 18-28-301.7 of the Municipal Code of Chicago is hereby amended by deleting the language stricken through and by inserting the language underscored, as follows:

18-28-301.7 Electrical.

Electrical wiring, controls and connections to equipment and appliances regulated by this chapter shall be in accordance with ~~Chapter 18-27, Electrical Systems~~ Title 14E of this Code.

SECTION 74. Section 18-29-301.6 of the Municipal Code of Chicago is hereby amended by deleting the language stricken through and by inserting the language underscored, as follows:

18-29-301.6 Prohibited locations.

Plumbing systems shall not be located in an exit stair shaft, an elevator shaft or in an elevator equipment room and other locations indicated in Titles 13-15.

Exception: Floor drains, sumps and sump pumps shall be permitted at the base of the shaft provided they are indirectly connected to the plumbing system. Refer to ~~Chapter 18-27~~ Title 14E of this Code for additional prohibited electrical locations.

SECTION 75. Section 18029-1111.3.3 of the Municipal Code of Chicago is hereby amended by deleting the language stricken through and by inserting the language underscored, as follows:

18-29-1111.3.3 Electrical.

Electrical service outlets, when required, shall meet the requirements of ~~Chapter 18-27~~ Title 14E of this Code.

SECTION 76. Section 18-29-1204.15 of the Municipal Code of Chicago is hereby amended by deleting the language stricken through and by inserting the language underscored, as follows:

18-29-1204.15 Electrical installations.

All electrical installations provided for, installed and used in conjunction with private residential swimming pools shall be in conformance with ~~Chapter 18-27 Electrical code~~ Title 14E of this Code.

**ARTICLE III.
REPEALER OF EXISTING ELECTRICAL CODE**

SECTION 1. Chapter 18-27 of the Municipal Code of Chicago, "Chicago Electrical Code," is hereby repealed in its entirety.

**ARTICLE IV.
ADMINISTRATION**

SECTION 1. Section 13-16-020 of the Municipal Code of Chicago is hereby amended by deleting the language stricken through and by inserting the language underscored, as follows:

13-16-020 New materials – Application for determination – Fee.

Any person desiring to submit any building materials, methods or systems of construction, or arrangements of material not provided for in the building provisions of this Code and which have not been previously approved for use by the building commissioner or certified by the committee on standards and tests, for determining the adaptability or safety of such materials, methods, systems or arrangements for building purposes, or to establish the safety qualifications of any substance for occupancy purposes, shall make application in writing to the building commissioner setting forth the merits claimed, and the purposes desired, together with such laboratory tests and other supporting data as the applicant may wish to furnish. If, in the judgment of the building commissioner, further evidence is necessary of the adaptability or safety of such materials, methods, systems, arrangements or safety qualifications, the building commissioner may require further tests to be made or additional data to be submitted by the applicant.

The fee for such application shall be ~~\$125.00~~ \$750.00 payable to the comptroller of which fee 50 percent shall be refunded to the applicant only in the event said application shall be disapproved.

SECTION 2. Section 13-24-060 of the Municipal Code of Chicago is hereby amended by deleting the language stricken through and by inserting the language underscored, as follows:

13-24-060 Appeal procedure.

The person, firm or corporation who is desiring review of an order or decision of the Building Commissioner pertaining to building permits shall file with the chairman of the Building Board of Appeals a written petition, on a form to be provided, within 14 days after the particular order or decision to be reviewed has been issued by the Building Commissioner, requesting that the particular order or decision be reviewed by the Building Board of Appeals. The person, firm or corporation requesting such review shall also file with the chairman any and all pertinent data or information that he or it may care to present to the Building Board of Appeals for its consideration, together with a filing fee payable to the City of Chicago in the amounts as follows:

- (a) For one-family dwellings as defined in Section 13-56-030 ~~of this Code and miscellaneous buildings and structures as defined in Section 13-56-220 of this Code and private garages and carports as defined in Section 13-96-260~~ ~~\$100.00~~ \$200.00
- (b) For buildings containing two to four dwelling units \$150.00
- (c) For all other occupancies ~~\$250.00~~ \$500.00

(Omitted text is unaffected by this ordinance)

SECTION 3. Section 13-32-031 of the Municipal Code of Chicago is hereby amended by deleting the language stricken through and by inserting the language underscored, as follows:

13-32-031 Sundry programs.

(a) The building commissioner shall have authority to institute the preliminary review program, the customized review program, the superstructure permit program, the developer services program, and other programs which may include programs authorizing qualified licensed design professionals to self-certify plans presented to the building commissioner pursuant to the requirements of Chapter 13-40 for compliance with the requirements of this code, and, to issue permits and to assess fees thereunder accordingly. Applications under these programs shall be in such form as shall be prescribed by the building commissioner. The building commissioner shall have authority to promulgate such rules ~~and regulations~~ as necessary for the implementation of these programs, including, but not limited to, the establishment of eligibility criteria and fees for participation in such programs, ~~and~~ auditing procedures and suspension or removal from such programs.

(b) If a permit applicant requests permit services provided under any program described in subsection (a) of this section, and participation in such program ~~is not required as~~ is a condition to permit issuance, the applicant may be assessed a fee to participate in such ~~optional program and shall be informed at the time of the request of the amount of such~~ fee. Such fee, ~~which shall be assessed in 15-minute increments,~~ shall be based on the costs, including actual and related costs incurred, to the department of buildings ~~and shall be calculated according to the amount of time and number of employees dedicated to the request.~~ Such fee, which the commissioner may promulgate by rule, shall be assessed in addition to the required permit fee.

**ARTICLE V.
SMOKE AND CARBON MONOXIDE DETECTION**

SECTION 1. Section 2-14-155 of the Municipal Code of Chicago is hereby amended by inserting the language underscored, as follows:

2-14-155 Defenses to building code violations.

It shall be a defense to a building code violation adjudicated under this article, if the owner, manager, person exercising control, his attorney, or any other agent or representative proves to the administrative law officer that:

(Omitted text is unaffected by this ordinance)

(b) At the time of the hearing on the issue of whether the building code violation does or does not exist, the violation has been remedied or removed. This subsection (b) shall not create a defense to a violation of Section 13-12-135(d)(5)(C), or to a person or entity that is an architect, structural engineer, contractor or builder who has been charged with a violation of Section 13-12-050 or Section 13-12-060 of this Code; nor shall it be a defense for any violation

of Section 13-20-550 or Section 17-12-0709 pertaining to any off-premises sign, as that term is defined in Section 17-17-02108; nor shall it be a defense for any violation of Section 4-6-290(f)(5)(i), Sections 13-64-120 through 13-64-180, Section 13-64-400(m), Section 13-80-030(c), Section 13-84-350, Sections 13-196-100 through 13-196-160, Sections 13-196-240(d), Section 13-196-240(f) or Section 13-208-130 pertaining to smoke alarms or smoke detectors; nor shall it be a defense for any violation of Sections 13-64-190 through 13-64-280 or Section 13-196-165 pertaining to carbon monoxide detectors. However, for violations of Sections 13-196-400 through 13-196-440 of this Code, it shall be a defense under this subsection only where the violation has been remedied or removed within seven days of service of notice of the building code violations as provided under Section 2-14-152;

(Omitted text is unaffected by this ordinance)

SECTION 2. Section 4-6-290 of the Municipal Code of Chicago is hereby amended by deleting the language stricken through and by inserting the language underscored, as follows:

4-6-290 Bed-and-breakfast establishment.

(Omitted text is unaffected by this ordinance)

(f) *Legal duties.* Each licensee engaged in the business of bed-and-breakfast establishment shall have a duty to:

(Omitted text is unaffected by this ordinance)

(5) comply with all applicable building and fire prevention provisions of this Code, and with any regulations promulgated thereunder. In addition, the following requirements shall be met:

(i) approved smoke ~~detectors~~ alarms equipped with an escape light, or approved smoke ~~detectors~~ alarms and approved unit battery equipment for emergency illumination or any approved System II or System III emergency lighting system, shall be installed in each sleeping room and stairway and in all other locations required by Chapter 13-64 of this Code. In addition to these smoke ~~detectors~~ alarms, each establishment shall provide at least one smoke ~~detector~~ alarm, which may be either portable or permanently wired, that emits a flashing or stroboscopic light signal or vibration to indicate the presence of smoke designed to serve hearing impaired persons as required by Section 13-64-180. For purposes of this subsection, an approved smoke ~~detector~~ alarm shall be the ionization chamber or photoelectric type, either battery powered or 110 volt AC, and shall bear the label of a nationally recognized standards testing laboratory indicating that the smoke ~~detector~~ alarm has been tested and listed as a single or single and multiple station smoke ~~detector~~ alarm. Approved unit battery equipment shall meet the requirements of Section ~~18-27-700.66~~ 14E-7-700.66 of this Code;

(Omitted text is unaffected by this ordinance)

SECTION 3. Section 4-6-300 of the Municipal Code of Chicago is hereby amended by inserting the language underscored, as follows:

4-6-300 Vacation rentals.

(Omitted text is unaffected by this ordinance)

(f) *Legal duties.*

(Omitted text is unaffected by this ordinance)

(11) *Smoke alarms and carbon monoxide detectors – Required.* Each licensee engaged in the business of vacation rental shall have a duty to ensure that the vacation rental is in compliance with applicable laws regarding the installation and maintenance of functioning smoke alarms and carbon monoxide detectors.

(Omitted text is unaffected by this ordinance)

SECTION 4. Section 4-14-040 of the Municipal Code of Chicago is hereby amended by inserting the language underscored, as follows:

4-14-040 Legal duties.

(Omitted text is unaffected by this ordinance)

(b) *Operating requirements.* Each shared housing host shall comply with the following operating requirements:

(Omitted text is unaffected by this ordinance)

(5) *Smoke alarms and carbon monoxide detectors – Required.* Each shared housing host shall ensure that the shared housing unit is in compliance with applicable laws regarding the installation and maintenance of functioning smoke alarms and carbon monoxide detectors.

(Omitted text is unaffected by this ordinance)

SECTION 5. Section 5-12-110 of the Municipal Code of Chicago is hereby amended by inserting the language underscored, as follows:

5-12-110 Tenant remedies.

In addition to any remedies provided under federal law, a tenant shall have the remedies specified in this section under the circumstances herein set forth.

(Omitted text is unaffected by this ordinance)

Failure to provide smoke alarms, smoke detectors, sprinkler systems, standpipe systems, fire alarm systems, automatic fire detectors or fire extinguishers where required by the municipal code;

(Omitted text is unaffected by this ordinance)

SECTION 6. Section 13-4-010 of the Municipal Code of Chicago is hereby amended by inserting, in correct alphabetical order, the language underscored, as follows:

For the purpose of this Code, the following terms shall be construed as follows:

(Omitted text is unaffected by this ordinance)

“Smoke Alarm” means a single- or multiple-station alarm responsive to smoke.

“Smoke Alarm, Multiple-Station” means two or more single-station alarm devices that can be interconnected such that actuation of one causes all integral or separate audible alarms to operate. A multiple-station alarm device can consist of one single-station alarm device having connections to other detectors or to a manual fire alarm box.

“Smoke Alarm, Single-Station” means an assembly incorporating the detector, the control equipment, and the alarm-sounding device in one unit, operated from a power supply either in the unit or obtained at the point of installation.”

“Smoke Detector” means a listed device that senses visible or invisible particles of combustion.

(Omitted text is unaffected by this ordinance)

SECTION 7. Table 13-48-030 of the Municipal Code of Chicago is hereby amended by deleting the language stricken through and by inserting the language underscored, as follows:

Table 13-48-030
MAXIMUM ALLOWABLE HEIGHTS OF BUILDINGS

(Omitted text is unaffected by this ordinance)

NOTES:

(Omitted text is unaffected by this ordinance)

(d) In an existing heavy timber building the height may be increased to 120 feet, 80 feet for new buildings, regardless of the number of stories when the building is brought into full compliance with the following:

(1) The High Rise Code, Chapter 13-76 specifically the sprinkler alternate, Section 13-76-100;

(2) Smoke detectors alarms, Sections 13-64-120 through 13-64-180;

(Omitted text is unaffected by this ordinance)

SECTION 8. Section 13-64-120 of the Municipal Code of Chicago is hereby amended by deleting the language stricken through and by inserting the language underscored, as follows:

13-64-120 Smoke alarms detectors – Required in all residential units.

All buildings of residential occupancy or mixed occupancy having any residential units, ~~except those complying with the terms of Chapter 13-76 of this Code, having any residential units,~~ shall be equipped with approved smoke alarms ~~detectors~~ in the manner prescribed in this section chapter.

SECTION 9. Section 13-64-130 of the Municipal Code of Chicago is hereby amended by deleting the language stricken through and by inserting the language underscored, as follows:

13-64-130 Smoke alarms detectors – Location.

Not less than one approved smoke detector alarm shall be installed in every single-family residential unit ~~and multiple dwelling units as defined in Chapter 13-56, Sections Section 13-56-020, 13-56-030 and 13-56-040.~~ The detector smoke alarm shall be installed on the ceiling and at least four inches from any wall or on a wall located from four to 12 inches from the ceiling, and within 15 feet of all rooms used for sleeping purposes, with not less than one detector smoke alarm per level, containing a habitable room or unenclosed heating plant.

(a) Installation near cooking appliances. Smoke alarms shall not be installed in the following locations unless this would prevent placement of a smoke alarm in a required location.

(1) Ionization smoke alarms shall not be installed less than 20 feet horizontally from a permanently installed cooking appliance.

(2) Ionization smoke alarms with an alarm-silencing switch shall not be installed less than 10 feet horizontally from a permanently installed cooking appliance.

(3) Photoelectric smoke alarms shall not be installed less than 6 feet horizontally from a permanently installed cooking appliance.

(b) Installation near bathrooms. Smoke alarms shall not be installed less than 3 feet horizontally from the door or opening of a room that contains a bathtub or shower unless this would prevent placement of a smoke alarm in a required location.

SECTION 10. Section 13-64-140 of the Municipal Code of Chicago is hereby amended by deleting the language stricken through and by inserting the language underscored, as follows:

13-64-140 Smoke detectors alarms – Stairwell installation.

In buildings of Types II, III or IV construction, ~~multiple~~ Multiple dwellings, as defined in Section 13-56-040, and buildings of mixed occupancy having any residential units, shall contain not less than one approved smoke detector alarm at the uppermost ceiling of all interior stairwells. All approved smoke detectors alarms herein required shall be installed on the ceiling, at least four inches from the wall or on a wall located from four to 12 inches from the ceiling.

SECTION 11. Section 13-64-141 of the Municipal Code of Chicago is hereby amended by inserting a new Section 13-64-141, as follows:

13-64-141 Smoke detection system in lieu of smoke alarms.

Smoke detectors listed in accordance with UL 268-09 and provided as part of the building fire alarm system shall be an acceptable alternative to single- and multiple-station smoke alarms and shall comply with the following:

- (1) The fire alarm system shall comply with all applicable requirements in Chapter 15-16.
- (2) Activation of a smoke detector in a dwelling unit or sleeping area other than a dwelling unit shall initiate alarm notification in the dwelling unit or sleeping area.
- (3) Activation of a smoke detector in a dwelling unit or sleeping area other than a dwelling unit shall not activate alarm notification appliances outside of the dwelling unit or sleeping area, provided that a supervisory signal is generated and monitored in accordance with Chapter 15-16.

SECTION 12. Section 13-64-150 of the Municipal Code of Chicago is hereby amended by deleting the language stricken through and by inserting the language underscored, as follows:

13-64-150 Smoke alarms and smoke detectors – Standards.

All approved smoke alarms and detectors herein required shall be either the ionization chamber or the photoelectric type and shall comply with ~~Chapter 18-27 of the Municipal Code of Chicago~~ Title 14E of this Code. ~~Detectors~~ Smoke alarms shall bear the label of a nationally recognized standards testing laboratory that indicates that the smoke ~~detectors~~ alarms have been tested and listed as a single or single and multiple station smoke ~~detectors~~ alarms. All approved smoke ~~detectors~~ alarms installed in buildings hereafter erected or converted to residential use on or after June 1, 1984, shall be permanently wired to the electrical service of each dwelling unit in accordance with the provisions of ~~Chapter 18-27~~ Title 14E of this Code.

In buildings required to have a standard fire alarm system as specified in Chapter 15-16 of this Code and in ~~nonsprinklered buildings complying with~~ subject to Chapter 13-76 of this Code, smoke detectors in dwelling units shall be of the type tested and listed for fire protection signaling systems and shall have an integral audible device.

SECTION 13. Chapter 13-64 of the Municipal Code of Chicago is hereby amended by inserting a new Section 13-64-151, as follows:

13-64-151 Smoke alarms – Additional requirements.

In: (i) all buildings erected or converted to residential use, and (ii) all dwelling units substantially altered, on or after March 1, 2018, smoke alarms shall also comply with the following requirements:

(a) *Standards for Listing and Installation.* Single- and multiple-station smoke alarms shall be listed in accordance with UL 217-06 and installed in accordance with NFPA 72-13.

(b) *Required Locations.* Single- or multiple-station smoke alarms shall be installed and maintained, regardless of occupant load, at the following locations:

(1) *On the ceiling or wall outside of each sleeping area in the immediate vicinity of bedrooms.*

(2) *In each room used for sleeping purposes.*

(3) *In each story within a dwelling unit, including basements, but not including crawl spaces and uninhabitable attics. In dwellings or dwelling units with split levels and without an intervening door between the adjacent levels, a smoke alarm installed on the upper level shall suffice for the adjacent lower level, provided that the lower level is less than one full story below the upper level.*

(c) *Interconnection.* Where more than one smoke alarm is required to be installed within an individual dwelling unit or sleeping area other than a dwelling unit, the smoke alarms shall be interconnected in such a manner that the activation of one alarm will activate all of the alarms in the individual unit. Physical interconnection of smoke alarms shall not be required where listed wireless alarms are installed and all alarms sound upon activation of one alarm. The alarm shall be clearly audible in all bedrooms over background noise with all intervening doors closed.

(d) *Power Source.* In new construction, required smoke alarms shall receive their primary power from the building wiring and shall be equipped with a battery backup. Smoke alarms with integral strobes that are not equipped with battery backup shall be connected to an emergency electrical system in accordance with 14E-7-700. Smoke alarms shall emit a signal when the batteries are low. Wiring shall be permanent and without a disconnecting switch other than as required for overcurrent protection.

Exception: Smoke alarms are not required to be equipped with battery backup where they are connected to an emergency electrical system that complies with Section 14E-7-700.

SECTION 14. Section 13-64-160 of the Municipal Code of Chicago is hereby amended by deleting the language stricken through and by inserting the language underscored, as follows:

13-64-160 Smoke detectors alarms – Battery removal violation – Penalty.

It shall be unlawful for any person to remove batteries or in any way make inoperable smoke detectors alarms as provided for in this chapter, except that this provision shall not apply to any building owner or manager or his agent in the normal procedure of replacing batteries.

(Omitted text is unaffected by this ordinance)

SECTION 15. Section 13-64-180 of the Municipal Code of Chicago is hereby amended by deleting the language stricken through and by inserting the language underscored, as follows:

13-64-180 Smoke detectors alarms – Hotels and motels and bed-and-breakfast establishments to provide smoke detectors to serve hearing impaired patrons.

In addition to the smoke detectors alarms required under Section 13-64-140, each hotel and motel and bed-and-breakfast establishment shall provide at least one smoke detector alarm designed to serve hearing impaired persons, for each 50 units or fraction thereof. If a patron of a hotel or motel requests a smoke detector alarm designed to serve hearing impaired persons, it shall be the duty of the hotel operator or motel operator to provide installation of such a smoke detector alarm. For purposes of compliance with this section, a smoke detector alarm is “designed to serve hearing impaired persons” if it emits a flashing or stroboscopic light signal or vibration to indicate the presence of smoke.

A smoke detector alarm required under this section may be either portable or permanently wired to the electrical service of the hotel or motel in accordance with the provisions of ~~Chapter 18-27 of this code~~ Title 14E of this Code. A hotel operator or motel operator may require that a patron pay a refundable deposit at the time of providing a portable smoke detector alarm for the patron's room. The amount of the deposit shall not exceed the cost of the portable smoke detector alarm.

Each hotel operator and each motel operator shall post a notice at the place of registration of patrons, bearing the legend “smoke detector alarm for the hearing impaired available”. The notice shall contain print no smaller than three inches high. The notice shall be posted in such a manner as to be visible to registering patrons.

SECTION 16. Section 13-64-190 of the Municipal Code of Chicago is hereby amended by deleting the language stricken through and by inserting the language underscored, as follows:

13-64-190 Carbon monoxide detectors – Required in residential units.

Every building of residential occupancy or mixed occupancy and having one or more residential units shall be equipped with approved carbon monoxide detectors in accordance with this chapter.

~~For purposes of this chapter “residential unit” includes Class A-1 single-family dwellings as defined in Section 13-56-030 of this Code and Class A-2 multiple dwellings as defined in Section 13-56-040 of this Code.~~

SECTION 17. Section 13-64-200 of the Municipal Code of Chicago is hereby amended by deleting the language stricken through and by inserting the language underscored, as follows:

13-64-200 Carbon monoxide detectors – Exemptions.

The following ~~residential~~ dwelling units shall not require carbon monoxide detectors:

(a) A ~~residential~~ dwelling unit in a building that (1) does not rely on combustion of fossil fuel for heat, ventilation, cooking, or hot water, (2) does not contain a fossil fuel burning fireplace, and (3) is not sufficiently close to any ventilated source of carbon monoxide, as determined by the building commissioner, to receive carbon monoxide from that source.

(b) A ~~residential~~ dwelling unit that (1) is heated by steam, hot water or electric heat, (2) does not contain a fossil fuel burning fireplace, and (23) is not connected by ductwork or ventilation shafts to any room containing a fossil fuel-burning boiler or heater, and (34) is not sufficiently close to any ventilated source of carbon monoxide, as determined by the building commissioner, to receive carbon monoxide from that source.

(Omitted text is unaffected by this ordinance)

SECTION 18. Section 13-64-210 of the Municipal Code of Chicago is hereby amended by deleting the language stricken through and by inserting the language underscored, as follows:

13-64-210 Carbon monoxide detectors – Location.

Not less than one approved carbon monoxide detector shall be installed in each ~~residential~~ dwelling unit or sleeping area other than a dwelling unit. ~~The~~ A detector shall be installed within 15 feet of ~~all rooms~~ each room used for sleeping purposes.

~~In~~ Additionally, in every hotel and motel, one approved carbon monoxide detector shall be installed for every 10,000 square feet of floor area, or fraction thereof, (a) on every floor on which a fossil fuel-burning boiler or furnace is located, and (b) on every floor on which sleeping rooms are heated by any type of warm air heating plant as described in Chapter 18-28 that burns fossil fuel. Floor area shall be computed separately for each floor.

Where a fuel-burning appliance is located within a bedroom or its attached bathroom, a detector shall be installed within the bedroom.

SECTION 19. Section 13-64-230 of the Municipal Code of Chicago is hereby amended by deleting the language stricken through and by inserting the language underscored, as follows:

13-64-230 Carbon monoxide detectors – Standards – Rules.

(a) Every approved carbon monoxide detector shall comply with all applicable federal and state regulations, and shall bear the label of a nationally recognized standard testing laboratory, and shall meet the standard of ~~UL~~ UL 2034 or its equivalent. The building commissioner shall may issue rules and regulations not inconsistent with the provisions of this chapter, for the implementation and administration of the provisions of this chapter relating to carbon monoxide detectors.

(b) In all buildings erected or substantially altered on or after the effective date of this amendatory ordinance of 2017, carbon monoxide detectors shall also comply with the following requirements:

(1) Detection equipment. Carbon monoxide detectors may be either carbon monoxide alarms complying with subsection (2) or carbon monoxide detection systems complying with subsection (3).

(2) Carbon monoxide alarms. Carbon monoxide alarms shall comply with the following:

(A) Power source. Carbon monoxide alarms shall receive their primary power from the building wiring, and when primary power is interrupted, shall receive power from a battery. Wiring shall be permanent and without a disconnecting means other than that required for overcurrent protection.

(B) Listing. Carbon monoxide alarms shall be listed in accordance with UL 2034-2008.

(C) Combination alarms. Combination carbon monoxide/smoke alarms shall be an acceptable alternative to carbon monoxide alarms. Combination carbon monoxide/smoke alarms shall be listed in accordance with UL 2034 and UL 217.

(3) Carbon monoxide detection systems. Carbon monoxide detection systems shall be an acceptable alternative to carbon monoxide alarms and shall comply with the following:

(A) General. Carbon monoxide detection systems shall comply with NFPA 720-15. Carbon monoxide detectors shall be listed in accordance with UL 2075.

(B) Locations. Carbon monoxide detectors shall be installed in the locations specified in 13-64-210. These locations supersede the locations specified in NFPA 720.

(C) *Combination detectors.* Combination carbon monoxide/smoke detectors installed in carbon monoxide detection systems shall be an acceptable alternative to carbon monoxide detectors, provided they are listed in accordance with UL 2075 and UL 268.

(c) *Maintenance.* Carbon monoxide detectors shall be maintained in accordance with NFPA 720-15. Carbon monoxide detectors that become inoperable or begin producing end-of-life signals shall be replaced.

SECTION 20. Section 13-64-270 of the Municipal Code of Chicago is hereby amended by deleting the language stricken through and by inserting the language underscored, as follows:

13-64-270 Carbon monoxide detectors – Location; Class B institutional and Class C assembly units.

In every Class B institutional unit as defined in Sections 13-56-050 and 13-56-060 and in every Class C assembly unit as defined in Section 13-56-070, not less than one approved carbon monoxide detector shall be installed per every 10,000 square feet, or fraction thereof, (a) on every floor on which a fossil fuel-burning appliance, boiler or furnace is located, and (b) on every floor heated by any type of warm air heating plant as described in Chapter 18-28 that burns fossil fuel. On every floor of a Class B institutional unit which contains sleeping quarters, one approved carbon monoxide detector shall also be installed within 15 feet of all rooms each room used for sleeping purposes that are either (a) located near a fossil fuel burning appliance, boiler or furnace or (b) heated by any type of warm air heating plant, as described in Chapter 18-28, which burns fossil fuel. Floor area shall be computed separately for each floor.

SECTION 21. Section 13-64-280 of the Municipal Code of Chicago is hereby amended by deleting the language stricken through and by inserting the language underscored, as follows:

13-64-280 Carbon monoxide detectors – Buildings heated by central fossil fuel powered heating unit.

In every building, regardless of occupancy, that is heated by one main a central fossil fuel powered heating unit, ~~and that is not exempted under Section 13-64-200~~, one approved carbon monoxide detector must be installed in the room containing the central heating unit.

SECTION 22. Section 13-64-400 of the Municipal Code of Chicago is hereby amended by deleting the language stricken through and by inserting the language underscored, as follows:

13-64-400 Business live/work units.

(Omitted text is unaffected by this ordinance)

(m) ~~Smoke detectors alarms~~. At least one hardwired smoke ~~detector alarm~~ shall be installed in the non-residential portion of the business live/work unit. This ~~detector alarm~~ and the ~~detectors alarms~~ in the residential portion of the unit shall be wired in series so that if one ~~detector alarm~~ sounds an alarm all of the ~~detectors alarms~~ in the unit (residential and work space) will also sound an alarm.

SECTION 23. Section 13-84-351 of the Municipal Code of Chicago is hereby amended by deleting the language stricken through and by inserting the language underscored, as follows:

13-84-351 Temporary display booths.

All temporary booths erected within assembly units shall comply with the following minimum requirements:

a. One approved battery-operated smoke ~~detector alarm~~ for each 1,000 square feet of enclosed area; and

(Omitted text is unaffected by this ordinance)

SECTION 24. Section 13-160-050 of the Municipal Code of Chicago is hereby amended by deleting the language stricken through and by inserting the language underscored, as follows:

13-160-050 Minimum number of exits.

There shall be not less than two exits from every building, floor, space or room, except that one exit may be permitted from any room or space under the conditions outlined in subsection (a) through (b) of this section; and one exit may be permitted from a floor under the conditions outlined in subsections (c) through (o) of this section.

(Omitted text is unaffected by this ordinance)

(e) In multiple dwellings, one exit shall be permitted to a public corridor from a dwelling unit when the travel distance to the most remote door within the unit does not exceed 35 feet and 55 feet from the most remote point of the dwelling unit. Two corridor exit doors are required when these distances are exceeded.

(1) When the dwelling unit is equipped with approved smoke ~~detectors alarms~~ and/or automatic sprinklers the above travel distances may be increased to 40 feet and 60 feet respectively.

(Omitted text is unaffected by this ordinance)

SECTION 25. Section 13-196-100 of the Municipal Code of Chicago is hereby amended by deleting the language stricken through and by inserting the language underscored, as

follows:

13-196-100 Smoke detectors alarms– Where required.

All existing ~~dwelling residential~~ units as defined in Sections 13-56-020 through 13-56-040, inclusive shall be equipped with approved smoke detectors alarms in accordance with the provisions of Chapter 13-196, Sections 13-196-110 through and including 13-196-160.

SECTION 26. Section 13-196-110 of the Municipal Code of Chicago is hereby amended by deleting the language stricken through and by inserting the language underscored, as follows:

13-196-110 Smoke detectors alarms – Installation near sleeping rooms and in living levels.

Every owner, manager or agent of any building, as described in Section 13-196-100, shall install, in every dwelling unit, not less than one approved smoke alarm in accordance with Section 13-64-130 ~~detector on the uppermost ceiling, not less than four inches from any wall, or on a wall, located from 12 inches from the ceiling, and within 15 feet of all rooms used for sleeping purposes, with not less than one detector per living-level containing a habitable room or unenclosed heating plant.~~

SECTION 27. Section 13-196-120 of the Municipal Code of Chicago is hereby amended by deleting the language stricken through and by inserting the language underscored, as follows:

13-196-120 Smoke detectors alarms – Interior stairwell installation.

Every owner, manager or agent of any building of Type II, III or IV construction as described in Section 13-196-100, shall install not less than one approved smoke detector on the uppermost ceiling, not less than four inches from any wall, or on a wall, located from four to 12 inches from the uppermost ceiling of all interior stairwells in accordance with Section 13-64-140.

SECTION 28. Section 13-196 130 of the Municipal Code of Chicago is hereby amended by deleting the language stricken through and by inserting the language underscored, as follows:

13-196-130 Smoke detectors alarms – Standards.

All approved single station smoke detectors required in this chapter shall be the ionization or photoelectric type, either battery powered or 110 volt AC and shall comply with Title 14E ~~of the municipal code of Chicago~~ this Code. Smoke detectors shall bear the label of a nationally recognized standards testing laboratory that indicates that the smoke detectors have been tested and listed as single or single and multiple station smoke detectors.

In buildings required to have a standard fire alarm system as specified in Chapter 13-196 and hotel buildings of Type II, III or IV construction complying with Section 13-196-210, smoke detectors in dwelling units shall be of the type tested and listed for fire protection signaling systems and shall have an integral audible device.

Smoke detectors provided as part of a building fire alarm system in accordance with Section 13-64-141 shall be an acceptable alternative to smoke alarms required by this chapter.

SECTION 29. Section 13-196-140 of the Municipal Code of Chicago is hereby amended by deleting the language stricken through and by inserting the language underscored, as follows:

13-196-140 ~~Smoke detectors~~ alarms – Owner/tenant responsibilities.

The owner shall be responsible for testing and maintaining ~~detectors~~ smoke alarms in common stairwells. It shall be the responsibility of the tenant to provide and maintain functional batteries for each ~~detector~~ smoke alarm; test and maintain ~~detectors~~ smoke alarms within dwelling units and to notify the owner or authorized agent in writing of any deficiencies. The owner shall be responsible for providing each tenant with written information regarding ~~detector~~ smoke alarm testing and maintenance.

The owner shall be responsible for testing and maintaining any smoke detector or smoke alarm that is part of a building fire alarm system, including those located within dwelling units.

SECTION 30. Section 13-196-150 of the Municipal Code of Chicago is hereby amended by deleting the language stricken through and by inserting the language underscored, as follows:

13-196-150 ~~Smoke detectors~~ alarms – Unlawful acts.

It shall be unlawful for any person to remove batteries or in any way make inoperable smoke ~~detectors~~ alarms as provided for in this chapter.

SECTION 31. Section 13-196-160 of the Municipal Code of Chicago is hereby repealed in its entirety.

SECTION 32. Section 13-196-240 of the Municipal Code of Chicago is hereby amended by deleting the language stricken through and by inserting the language underscored, as follows:

13-196-240 ~~Automatic fire detectors~~ – Where required.

(Omitted text is unaffected by this ordinance)

(g) In single-room occupancy buildings, automatic heat detectors shall be installed in each single-room occupancy unit, in public corridors, and at each floor level in every interior stairwell. In single-room occupancy buildings, smoke ~~detectors~~ alarms required by Section 13-196-100 ~~of this Code~~ need not be connected to the fire alarm system, but shall be permanently wired to the electrical wiring system of the building.

SECTION 33. Section 13-200-160 of the Municipal Code of Chicago is hereby amended by deleting the language stricken through and by inserting the language underscored, as follows:

13-200-160 Requirements for change to residential occupancy.

When the occupancy of an existing building is changed from any occupancy classification to residential, the following requirements shall be met:

(Omitted text is unaffected by this ordinance)

(h) All residential buildings shall be provided with smoke ~~detectors~~ alarms, as required for new construction in Chapter 13-64 of this Code.

(Omitted text is unaffected by this ordinance)

SECTION 34. Section 13-200-300 of the Municipal Code of Chicago is hereby amended by deleting the language stricken through and by inserting the language underscored, as follows:

13-200-300 Alterations and repairs.

In alterations or repairs to an existing building, all new construction shall comply with the applicable provisions of the ~~code~~ this Code for new construction, except as follows:

(Omitted text is unaffected by this ordinance)

(e) In buildings containing not more than three dwelling units, basement recreation rooms not used for sleeping purposes may comply with the following minimum requirements when smoke ~~detectors~~ alarms complying with Sections 13-196-100 through and including 13-196-160 are provided in each dwelling unit in the building and in that portion of the basement used as a recreation room:

(Omitted text is unaffected by this ordinance)

SECTION 35. Section 13-208-130 of the Municipal Code of Chicago is hereby amended by deleting the language stricken through and by inserting the language underscored, as follows:

13-208-130 Smoke detectors alarms.

Approved smoke detectors alarms, as described in Section 13-64-150 of this Code, shall be installed and maintained in the manner designated in said chapter, in each temporary overnight shelter, as follows:

(Omitted text is unaffected by this ordinance)

SECTION 36. Section 15-16-060 of the Municipal Code of Chicago is hereby amended by deleting the language stricken through and by inserting the language underscored, as follows:

15-16-060 Smoke detector alarm requirements.

Requirements for smoke detectors alarms in residential buildings shall be as provided in Section 13-64-120.

SECTION 37. Section 15-16-351 of the Municipal Code of Chicago is hereby amended by deleting the language stricken through and by inserting the language underscored, as follows:

15-16-351 Display booths.

(Omitted text is unaffected by this ordinance)

(3) *Fire Prevention and Detection:*

(Omitted text is unaffected by this ordinance)

b. Temporary display booths shall comply with the smoke detector alarm and fire extinguisher requirements in at Section 13-84-351(a) or (b) of this code.

(Omitted text is unaffected by this ordinance)

**ARTICLE VI.
EFFECTIVE DATES**

SECTION 1. Articles I and IV of this Ordinance shall take full force and effect 30 days after its passage and publication. On or after the effective date of Article I, and before the effective date of Article III, the Commissioner of Buildings may allow a permit applicant to proceed under the provisions of either Title 14E or the provisions of Chapter 18-27. Articles II, III, and V of this ordinance shall take full force and effect on March 1, 2018. On and after that date, any citation issued for a violation of former Chapter 18-27 shall be deemed issued under

the corresponding section of Title 14E. Each day that a violation continues shall constitute a separate and distinct offense.