



# City of Chicago



O2017-8161

Office of the City Clerk

## Document Tracking Sheet

<b>Meeting Date:</b>	11/8/2017
<b>Sponsor(s):</b>	Solis (25)
<b>Type:</b>	Ordinance
<b>Title:</b>	Awning(s) for Mad Boiler
<b>Committee(s) Assignment:</b>	Committee on Transportation and Public Way

ORDINANCE  
MAD BOILER  
Acct. No. 404516 - 1  
Permit No. 1129072

*Be It Ordained by the City Council of the City of Chicago:*

SECTION 1. Permission and authority are hereby given and granted to MAD BOILER, upon the terms and subject to the conditions of this ordinance to construct, install, maintain and use one (1) Awning(s) projecting over the public right-of-way adjacent to its premises known as 1045 W. Madison St..

Said Awning(s) at W. Madison measure(s):

One (1) at six point two nine (6.29) feet in length, and one point six seven (1.67) foot in width for a total of ten point five (10.5) square feet.

The location of said privilege shall be as shown on prints kept on file with the Department of Business Affairs and Consumer Protection and the Office of the City Clerk.

Said privilege shall be constructed in accordance with plans and specifications approved by the Zoning Department - Signs.

This grant of privilege in the public way shall be subject to the provisions of Section 10-28-015 and all other required provisions of the Municipal Code of Chicago.

The grantee shall pay to the City of Chicago as compensation for the privilege #1129072 herein granted the sum of fifty (\$50.00) per annum in advance.

A 25% penalty will be added for payments received after due date.

The permit holder agrees to hold the City of Chicago harmless for any damage, relocation or replacement costs associated with damage, relocation or removal of private property caused by the City performing work in the public way.

Authority herein given and granted for a period of five (5) years from and after Date of Passage.

Alderman \_\_\_\_\_

  
Daniel S. Solis 25th Ward

# SIGN 3: AWNING

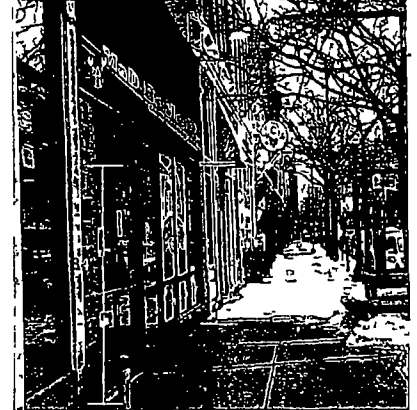
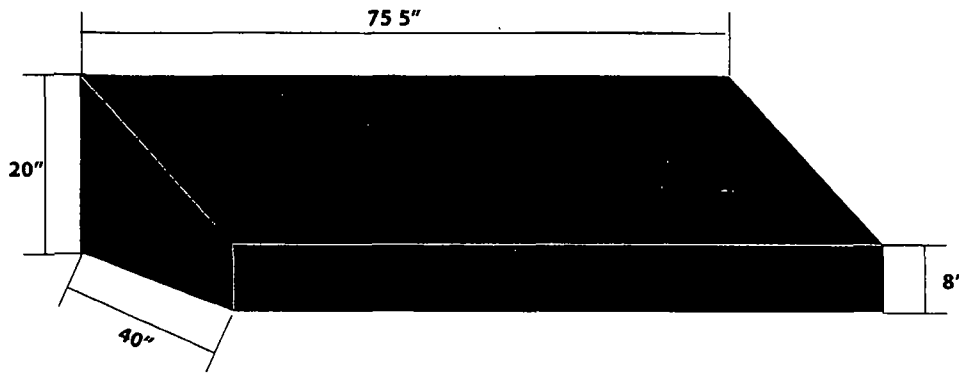

## SPECIFICATIONS

## COLOR SCHEDULE

## MOUNTING DETAIL

- 1 AWNING FABRIC MATERIAL
- 2 1"X 1" SQUARE TUBE FRAME
- 3 3/16" GALVANIZED STEEL Z-CLIP ATTACHMENT
- 4 APPROPRIATE NON-CORROSIVE WALL FASTENER  
3/8 IN ZINC-PLATED HEX LAG SCREW  
SPACING EACH 4 FT  
SEE MOUNTING OPTION DETAILS
- 5 #12 TEK SCREW

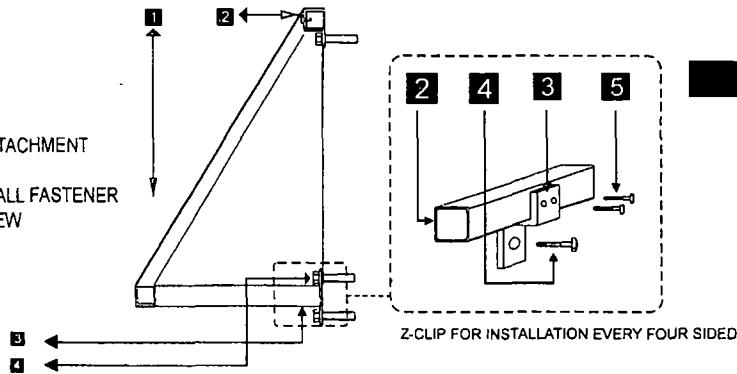

<b>Thru-Bolt Mounting</b>	
<b>Hanger Bolts</b>	
<b>Reverse Toggle Bolt Mounting</b>	
<b>Masonry Lag Bolt Mounting</b>	



**Client Name**  
Mad Boiler

**Location**  
1045 W Madison St  
Chicago IL 60607

**Start Date** 03/31/2016

**Last Revision**

**Job#**

**Drawing#**

**Page** 5/6

- Client Approval
- Landlord Approval

**Sales Rep**  
kw  
**Designer**  
SL





11/08/2017

Alderman **Daniel S. Solis**

Ward # 25

City of Chicago

City Hall, Room 304

121 North LaSalle Street

Chicago, Illinois 60602

Re: An ordinance to use and maintain a portion of the public right-of-way for **one (1) awning(s)** for **MAD BOILER**, adjacent to the premises known as **1045 W. Madison St.**

Dear Alderman **Daniel S. Solis**:

The applicant referenced above has requested the use of the public right-of-way for a **awning(s)**. An ordinance has been prepared by the Department of Business Affairs and Consumer Protection – Small Business Center - Public Way Use Unit for presentation to the City Council. Because this request was made for properties located in your ward, as approved by you as per the attached, I respectfully request that you introduce the attached ordinance at the next City Council meeting.

If you have any questions regarding this ordinance, please contact Anthony Bertuca at (312) 744-5506.

**Department of Business Affairs and Consumer Protection**