



# City of Chicago



O2013-8287

Office of the City Clerk

## Document Tracking Sheet

<b>Meeting Date:</b>	10/16/2013
<b>Sponsor(s):</b>	Cochran (20)
<b>Type:</b>	Ordinance
<b>Title:</b>	Grant(s) of privilege in public way for University of Chicago, The - File No. 23
<b>Committee(s) Assignment:</b>	Committee on Transportation and Public Way

ORDINANCE  
UNIVERSITY OF CHGO FILE #23  
Acct. No. 43697 - 28  
Permit No. 1108678

*Be It Ordained by the City Council of the City of Chicago:*

SECTION 1. Permission and authority are hereby given and granted to UNIVERSITY OF CHGO FILE #23, upon the terms and subject to the conditions of this ordinance to maintain and use, as now constructed, one (1) Pipe Trench(s) under the public right-of-way adjacent to its premises known as 6000 S. University Ave.. Existing pipe trench approximately five (5) feet in width and four (4) feet in depth containing an eight (8) inch steam main and a four (4) foot return in a fifteen (15) inch conduit place on concrete pads, eight (8) feet O.C. with well tapped sandfill above existing conduit. Containing C.I. plates, eight (8) inch reinforced concrete slab between curbs and ten (10) inch road bed over slab, under and across the eighty (80) foot public right-of-way, South University Avenue, twenty (20) feet south of the south line of East 60<sup>th</sup> Street, thence entering private property.

The location of said privilege shall be as shown on prints kept on file with the Department of Business Affairs and Consumer Protection and the Office of the City Clerk.

Said privilege shall be constructed in accordance with plans and specifications approved by the Department of Planning and Development, Department of Transportation (Office of Underground Coordination), and Department of Water Management.

This grant of privilege in the public way shall be subject to the provisions of Section 10-28-015 and all other required provisions of the Municipal Code of Chicago.

The grantee shall pay to the City of Chicago as compensation for the privilege #1108678 herein granted the sum of four hundred (\$400.00) per annum in advance.

A 25% penalty will be added for payments received after due date.

The permit holder agrees to hold the City of Chicago harmless for any damage, relocation or replacement costs associated with damage, relocation or removal of private property caused by the City performing work in the public way.

Authority herein given and granted for a period of five (5) years from and after 08/11/2013.

Alderman

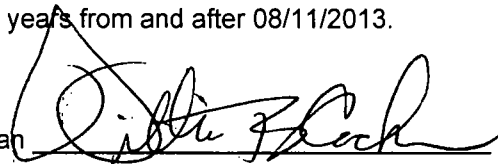

Willie Cochran 20th Ward

Acct 43697-28, UC File 23

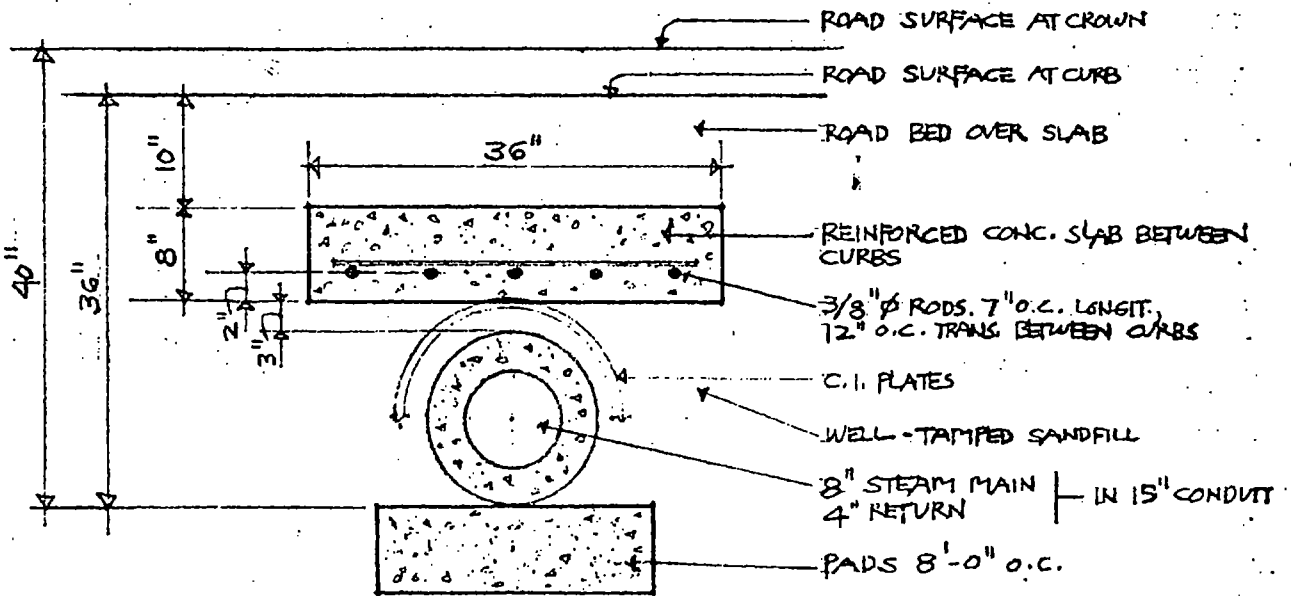
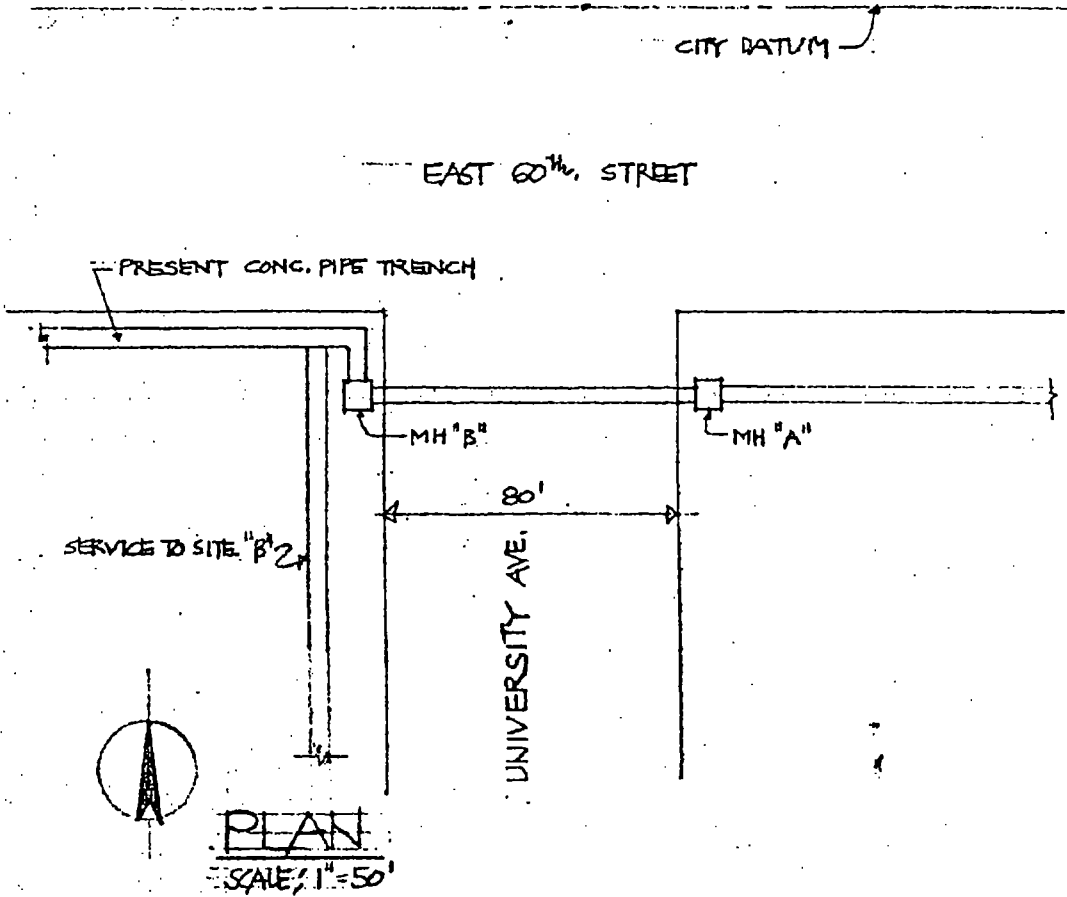

ORDINANCE DRAWINGS	DATE: 7/24/78	DRAWING NO. 78-92	THE UNIVERSITY OF CHICAGO Office of Physical Planning and Construction
	TUNNEL and CONDUIT LOCATIONS		



**10/16/2013**

**Alderman Willie Cochran**  
Ward # 20  
City of Chicago  
City Hall, Room 300  
121 North LaSalle Street  
Chicago, Illinois 60602

Re: An ordinance to use and maintain a portion of the public right-of-way for **one (1) pipe trench(s)** for **UNIVERSITY OF CHGO FILE #23**, adjacent to the premises known as **6000 S. University Ave.**

Dear Alderman **Willie Cochran**:

The applicant referenced above has requested the use of the public right-of-way for a **pipe trench(s)**. An ordinance has been prepared by the Department of Business Affairs and Consumer Protection – Business Assistance Center - Public Way Use Unit for presentation to the City Council. Because this request was made for properties located in your ward, as approved by you as per the attached, I respectfully request that you introduce the attached ordinance at the next City Council meeting.

If you have any questions regarding this ordinance, please contact Anthony Bertuca at (312) 744-5506.

**Department of Business Affairs and Consumer Protection**