



Office of the Chicago City
Clerk



O2011-7676

Office of the City Clerk

City Council Document Tracking Sheet

Meeting Date:	9/8/2011
Sponsor(s):	Waguespack, Scott (32)
Type:	Ordinance
Title:	Canopy(s) for Lakeview Medical Campus LLC
Committee(s) Assignment:	Committee on Transportation and Public Way

ORDINANCE

Lakeview Medical Campus, LLC

Acct. No. 364898 - 1

Permit No. 1097831

Be It Ordained by the City Council of the City of Chicago:

SECTION 1. Permission and authority are hereby given and granted to Lakeview Medical Campus, LLC, upon the terms and subject to the conditions of this ordinance to construct, install, maintain and use one (1) Canopy(s) projecting over the public right-of-way adjacent to its premises known as 1333 W. Belmont Ave..

Said Canopy(s) at W. Belmont Avenue measure(s):

One (1) at twenty-seven point seven five (27.75) feet in length, and eight point four two (8.42) feet in width for a total of two hundred thirty-three point six six (233.66) square feet.

The location of said privilege shall be as shown on prints kept on file with the Department of Business Affairs and Consumer Protection and the Office of the City Clerk.

Said privilege shall be constructed in accordance with plans and specifications approved by the Zoning Department - Signs.

This grant of privilege in the public way shall be subject to the provisions of Section 10-28-015 and all other required provisions of the Municipal Code of Chicago.

The grantee shall pay to the City of Chicago as compensation for the privilege #1097831 herein granted the sum of fifty-two dollars and seventy-five cents (\$52.75) per annum in advance.

A 25% penalty will be added for payments received after due date.

The permit holder agrees to hold the City of Chicago harmless for any damage, relocation or replacement costs associated with damage, relocation or removal of private property caused by the City performing work in the public way.

Authority herein given and granted for a period of five (5) years from and after Date of Passage.

Alderman



Scott Waguespack 32nd Ward

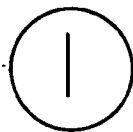
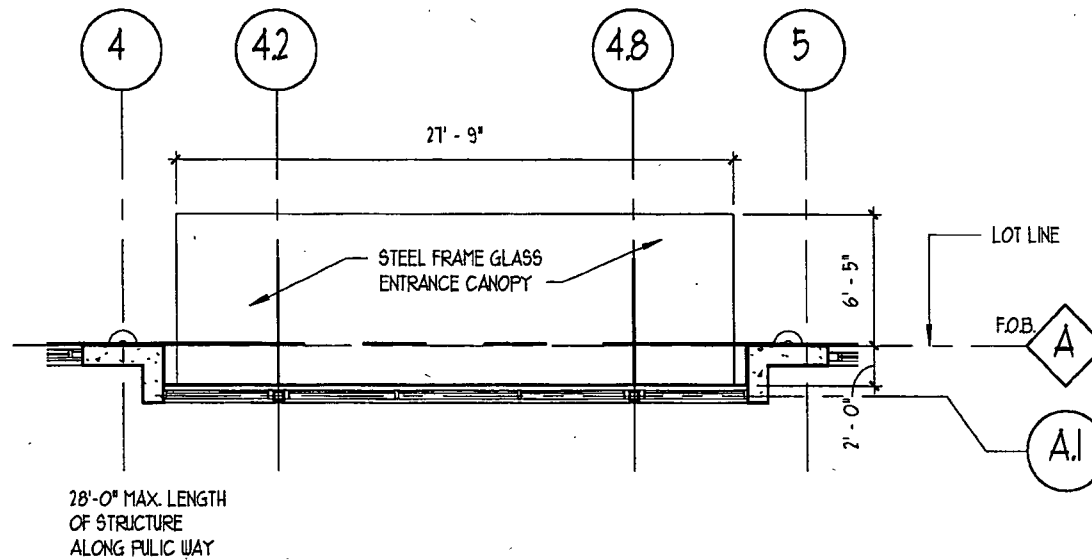

SECOND FLOOR (ROW CANOPY PLAN)

1/8" = 1'-0"

areté **KNIGHT**

Architecture • Engineering • Land Planning
Interiors • Graphic Design

18641 West Creek Drive • Tinley Park, IL 60477
Telephone (708) 342-1250 • Fax (708) 342-1240
A Division of Knight E/A, Inc. • knightea.com



09/08/2011

Alderman Scott Waguespack
Ward # 32
City of Chicago
City Hall, Room 300
121 North LaSalle Street
Chicago, Illinois 60602

Re: An ordinance to use and maintain a portion of the public right-of-way for **one (1) canopy(ies)** for **Lakeview Medical Campus, LLC**, adjacent to the premises known as **1333 W. Belmont Ave.**.

Dear Alderman **Scott Waguespack**:

The applicant referenced above has requested the use of the public right-of-way for a **canopy(ies)**. An ordinance has been prepared by the Department of Business Affairs and Consumer Protection – Business Assistance Center - Public Way Use Unit for presentation to the City Council. Because this request was made for properties located in your ward, as approved by you as per the attached, I respectfully request that you introduce the attached ordinance at the next City Council meeting.

If you have any questions regarding this ordinance, please contact John Mariane, Manager, Business Assistance Center - Public Way Use Unit, at (312) 744-2063.

Department of Business Affairs and Consumer Protection