



City of Chicago



O2014-9983

Office of the City Clerk

Document Tracking Sheet

Meeting Date:	12/10/2014
Sponsor(s):	Osterman (48)
Type:	Ordinance
Title:	Awning(s) for Rice Thai Asian Kitchen
Committee(s) Assignment:	Committee on Transportation and Public Way

ORDINANCE
RICE THAI ASIAN KITCHEN
Acct. No. 389599 - 1
Permit No. 1115118

Be It Ordained by the City Council of the City of Chicago:

SECTION 1. Permission and authority are hereby given and granted to RICE THAI ASIAN KITCHEN, upon the terms and subject to the conditions of this ordinance to construct, install, maintain and use one (1) Awning(s) projecting over the public right-of-way adjacent to its premises known as 1136 W. Thorndale Ave..

Said Awning(s) at W. Thorndale measure(s):

One (1) at seventeen (17) feet in length, and four (4) feet in width for a total of sixty-eight (68) square feet.

The location of said privilege shall be as shown on prints kept on file with the Department of Business Affairs and Consumer Protection and the Office of the City Clerk.

Said privilege shall be constructed in accordance with plans and specifications approved by the Zoning Department - Signs.

This grant of privilege in the public way shall be subject to the provisions of Section 10-28-015 and all other required provisions of the Municipal Code of Chicago.

The grantee shall pay to the City of Chicago as compensation for the privilege #1115118 herein granted the sum of fifty (\$50.00) per annum in advance.

A 25% penalty will be added for payments received after due date.

The permit holder agrees to hold the City of Chicago harmless for any damage, relocation or replacement costs associated with damage, relocation or removal of private property caused by the City performing work in the public way.

Authority herein given and granted for a period of five (5) years from and after Date of Passage.

Alderman _____

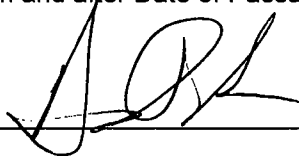

Harry Osterman 48th Ward

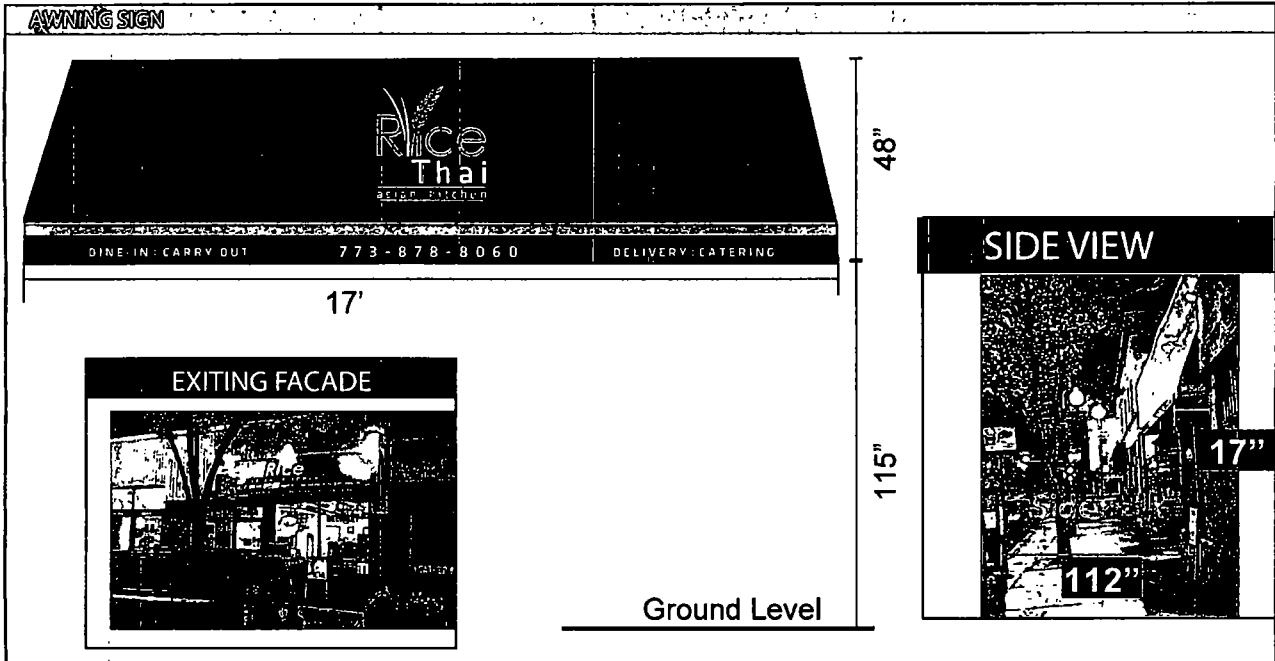

MONSIBIC
Signs & Graphic
(Bridgeport)
Chicago, IL
3401 S Halsted St
Chicago, IL 60608
773-847-2828
Fax 773-847-0088

BRIDGEPORT PASTY
SIGN ELEVATION EXHIBIT

Address: 1136 W Thorndale Ave
City: Chicago
State: IL 60660
Account Rep: K. WONG
Sales Rep: K. WONG

APPROVALS
CLIENT: _____
DESIGN: _____
PHOTO: _____
Designer: K. WONG
Design No: _____
DATE: 05-15-2014
Rev Date: _____
The purchaser agrees to hold the seller harmless against any claims for action for damage which may occur as a result of drilling for signs and foundations, including but not limited to power lines or any underground obstacles which the purchaser is either responsible for.

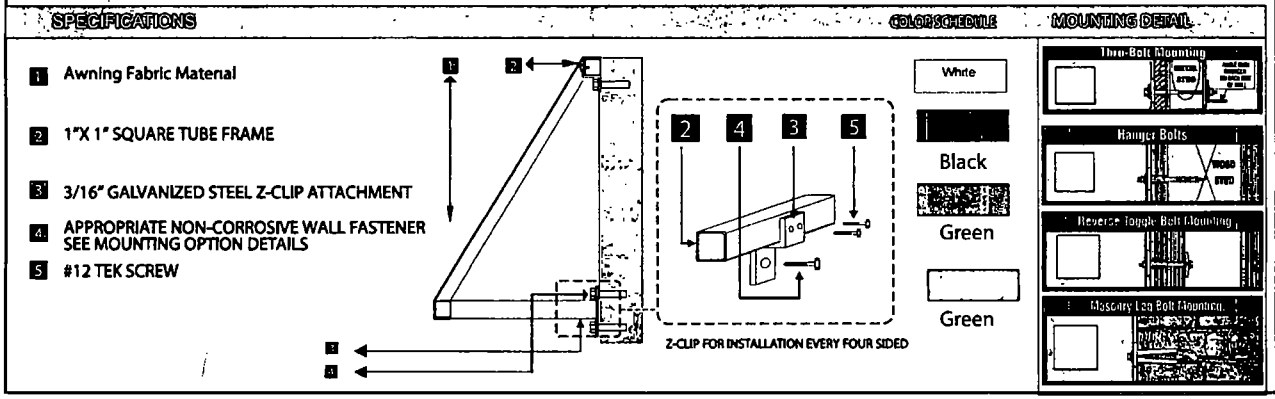

THIS DESIGN AND ENGINEERING IS SUBMITTED AS OUR PROPOSAL, AND THE RIGHT TO USE OR EXHIBIT IN ANY FORM, IS NOT AUTHORIZED WITHOUT WRITTEN PERMISSION BY MONSIBIC, INC.



12/10/2014

Alderman Harry Osterman
Ward # 48
City of Chicago
City Hall, Room 300
121 North LaSalle Street
Chicago, Illinois 60602

Re: An ordinance to use and maintain a portion of the public right-of-way for **one (1) awning(s)** for **RICE THAI ASIAN KITCHEN**, adjacent to the premises known as **1136 W. Thorndale Ave.**.

Dear Alderman **Harry Osterman**:

The applicant referenced above has requested the use of the public right-of-way for a **awning(s)**. An ordinance has been prepared by the Department of Business Affairs and Consumer Protection – Small Business Center - Public Way Use Unit for presentation to the City Council. Because this request was made for properties located in your ward, as approved by you as per the attached, I respectfully request that you introduce the attached ordinance at the next City Council meeting.

If you have any questions regarding this ordinance, please contact Anthony Bertuca at (312) 744-5506.

Department of Business Affairs and Consumer Protection