



# City of Chicago



O2016-5520

Office of the City Clerk  
Document Tracking Sheet

<b>Meeting Date:</b>	7/14/2016
<b>Sponsor(s):</b>	Smith (43)
<b>Type:</b>	Ordinance
<b>Title:</b>	Grant(s) of privilege in public way for Mattress Firm - sign
<b>Committee(s) Assignment:</b>	Committee on Transportation and Public Way

ORDINANCE  
MATTRESS FIRM  
Acct. No. 393595 - 37  
Permit No. 1123202

*Be It Ordained by the City Council of the City of Chicago:*

SECTION 1. Permission and authority are hereby given and granted to MATTRESS FIRM, upon the terms and subject to the conditions of this ordinance to maintain and use one (1) sign(s) projecting over the public right-of-way attached to its premises known as 2731 N. Clark St..

Said sign structure(s) measures as follows; along N. Clark:  
One (1) at twenty point five (20.5) feet in length, two (2) feet in height and twelve point two five (12.25) feet above grade level.

The location of said privilege shall be as shown on prints kept on file with the Department of Business Affairs and Consumer Protection and the Office of the City Clerk.

Said privilege shall be constructed in accordance with plans and specifications approved by the Department of Transportation (Division of Project Development) and Zoning Department - Signs.

This grant of privilege in the public way shall be subject to the provisions of Section 10-28-015 and all other required provisions of the Municipal Code of Chicago.

The grantee shall pay to the City of Chicago as compensation for the privilege #1123202 herein granted the sum of three hundred (\$300.00) per annum in advance.

A 25% penalty will be added for payments received after due date.

The permit holder agrees to hold the City of Chicago harmless for any damage, relocation or replacement costs associated with damage, relocation or removal of private property caused by the City performing work in the public way.

Authority herein given and granted for a period of five (5) years from and after Date of Passage.

Alderman \_\_\_\_\_

Michele Smith 43<sup>rd</sup> Ward

<b>SIGN A</b>	24 Mattress Firm Interior
<b>Sign Type:</b>	Channel Letters on a Raceway w/ Back Panel
<b>Illumination:</b>	Internally Illuminated LED
<b>Square Footage:</b>	41.08
<b>Height:</b>	Top of Sign to Grade 14.33'- Bottom of Sign to Grade 12.33'

20-012 246.172

# MATTRESS FIRM

## Sign Layout Detail

Scale: 3/8" = 1'-0"

### Electrical Detail:

- P LED Red and White LEDs
- (2) 100w Transformers @ 1.2 amps each
- Total Amps: 2.40
- (1) 20 amp 120V Circuit Req



### General Notes:

- This sign is to be installed in accordance with the requirements of Article 600 of the National Electrical Code
- 1) Grounded and bonded per NEC 600.7/NEC 250
- 2) Existing branch circuit in compliance with NEC 600.5 not to exceed 20 amps
- 3) Sign is to be UL listed per NEC 600.3
- 4) UL disconnect switch per NEC 600.6 required per sign component before leaving manufacturer. For multiple signs a disconnect is permitted but not required for each section.

### Specifications: Channel Letters / Backer Panel / Raceway

- 1 Existing Facade Metal
- 2 0.040 Aluminum letter returns painted to match black
- 3 0.125 x 1.1mm cap to match black
- 4 3mm Signabond Lite composite backs (interior of sign can painted ultra white for maximum illumination)
- 5 Red LEDs
- 6 3/16" R&H #2793 Red acrylic faces
- 7 Waterproof disconnect switch per NEC 600.6
- 8 Primary electrical lead
- 9 Transformers
- 10 0.080 Aluminum raceway painted to match the facade
- 11 15 x 2 x 0.1875 Aluminum mounting ribs welded to raceway. Maximum 6" from each end and every 48" o.c.
- 12 #12 x 1 TEC screws with 11/4 fender washers
- 13 Mounting hardware to suit
- 14 0.080 Backer panel painted to match black

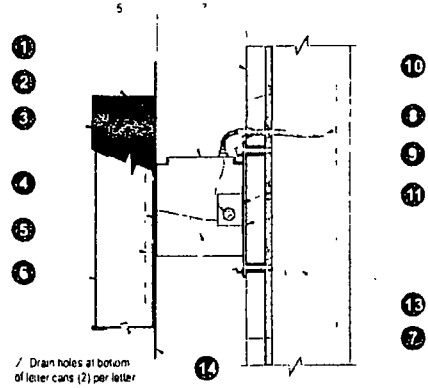

/ Drain holes at bottom of letter cars (2) per letter

### Section @ LED Channel Letter Backer Panel / Raceway

Scale: N.T.S.

	Client: Mattress	05/09/2014	Original Rendering	SD	
	Site #: Mt. 119216	06/15/2014	Update sign no. A19521 to 4LG, add SLEEPY TIME banners	CE	
	Address: 2731 North Clark Street Chicago, IL 60614	02/11/2016	Revised Sign # in Mattress Firm, New store ID 3119216	AP	
		02/27/2016	Non-to-L, rework Plan 119216	A	