



Office of the Chicago City  
Clerk



O2012-3905

Office of the City Clerk

City Council Document Tracking Sheet

<b>Meeting Date:</b>	6/6/2012
<b>Sponsor(s):</b>	Moreno, Proco Joe (1)
<b>Type:</b>	Ordinance
<b>Title:</b>	Grant(s) of privilege in public way for Regal Cinemas City North
<b>Committee(s) Assignment:</b>	Committee on Transportation and Public Way

ORDINANCE  
REGAL CINEMAS CITY NORTH  
Acct. No. 353500 - 1  
Permit No. 1094522

*Be It Ordained by the City Council of the City of Chicago:*

SECTION 1. Permission and authority are hereby given and granted to REGAL CINEMAS CITY NORTH, upon the terms and subject to the conditions of this ordinance to maintain and use five (5) sign(s) projecting over the public right-of-way attached to its premises known as 2600 N. Western Ave..

Said sign structure(s) measures as follows; along N western:

One (1) at five (5) feet in length, one (1) foot in height and thirty-two point six (32.6) feet above grade level.

Said sign structure(s) measures as follows; along n. western:

One (1) at thirty-eight point six (38.6) feet in length, three point one seven (3.17) feet in height and twenty-six (26) feet above grade level.

Said sign structure(s) measures as follows; along n. western:

One (1) at forty-two point seven five (42.75) feet in length, three point five (3.5) feet in height and sixteen (16) feet above grade level.

Said sign structure(s) measures as follows; along n. western:

One (1) at five (5) feet in length, two (2) feet in height and thirty-two point six (32.6) feet above grade level.

Said sign structure(s) measures as follows; along w. schubert:

One (1) at sixteen point eight (16.8) feet in length, thirty-seven point five (37.5) feet in height and twenty-nine (29) feet above grade level.

The location of said privilege shall be as shown on prints kept on file with the Department of Business Affairs and Consumer Protection and the Office of the City Clerk.

Said privilege shall be constructed in accordance with plans and specifications approved by the Department of Transportation (Division of Project Development) and Zoning Department - Signs.

This grant of privilege in the public way shall be subject to the provisions of Section 10-28-015 and all other required provisions of the Municipal Code of Chicago.

The grantee shall pay to the City of Chicago as compensation for the privilege #1094522 herein granted the sum of one thousand seventy-five (\$1,075.00) per annum in advance.

A 25% penalty will be added for payments received after due date.

The permit holder agrees to hold the City of Chicago harmless for any damage, relocation or replacement costs associated with damage, relocation or removal of private property caused by the City performing work in the public way.

Authority herein given and granted for a period of five (5) years from and after Date of Passage.

Alderman Scott Weigand for PRM  
Proco Joe Moreno 1<sup>st</sup> Ward

Regal Stadium 14  
 2600 N. Western Ave, Chicago, IL 60647  
 112710: Add REGAL STADIUM 14 copy to wall signs (4)  
 (A, C, D, E).

All signs to have UL label,  
 disconnect, drain holes,  
 and venting.

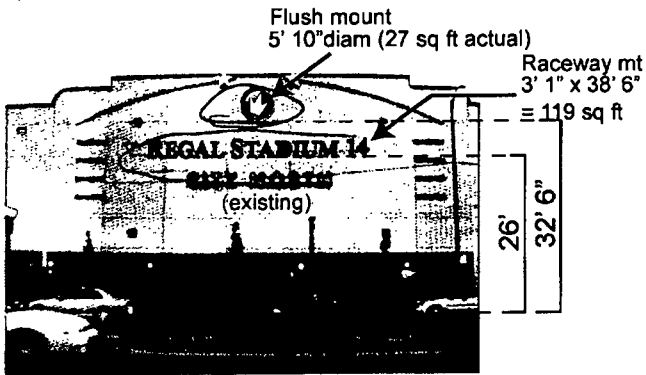

East Elevation **D**

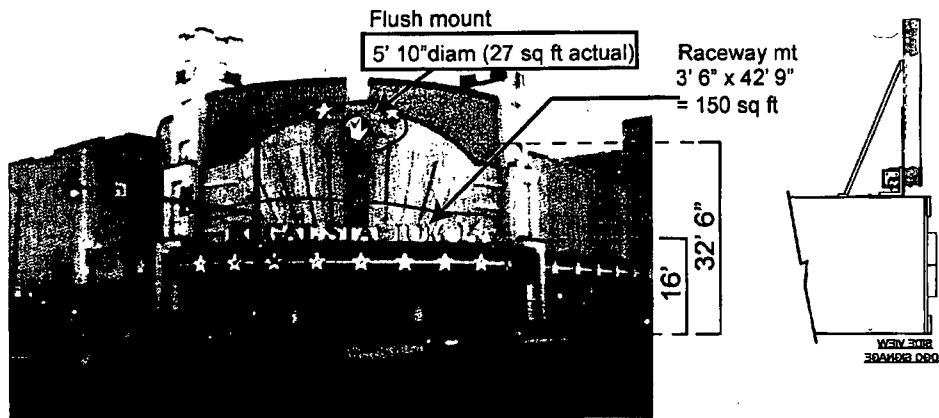
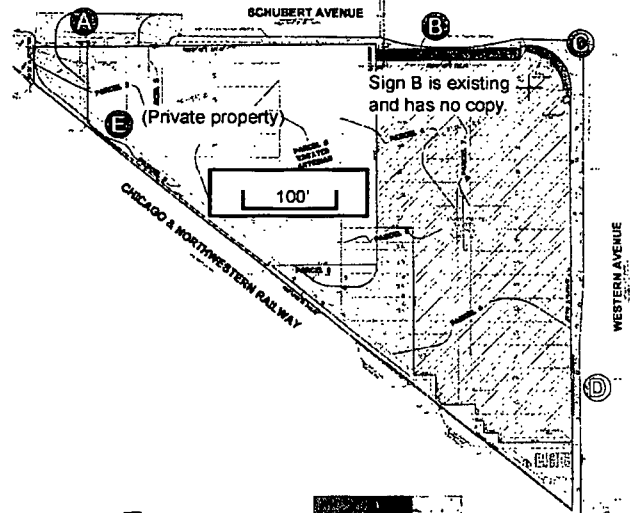

NE corner Elevation **C**



*Check back*

**A** Install new faces in sign A  
 7' 5" x 4' 8" at 27' elevation

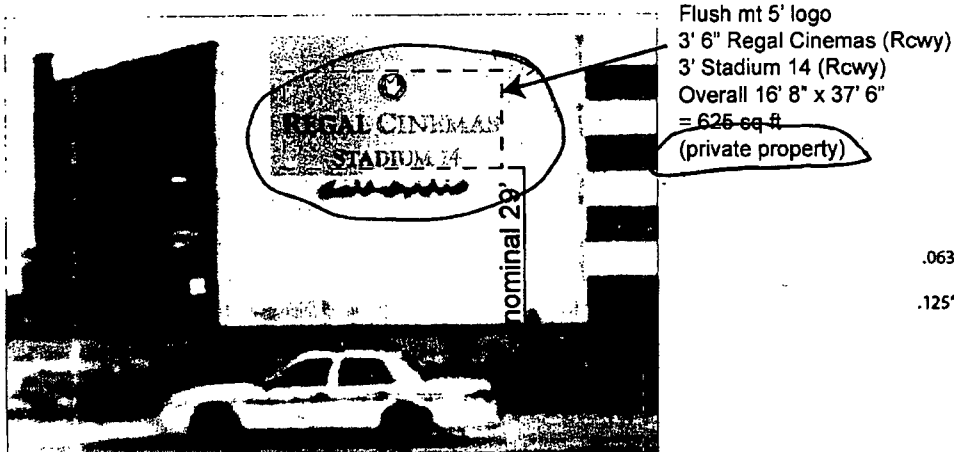

SW corner Elevation **E**

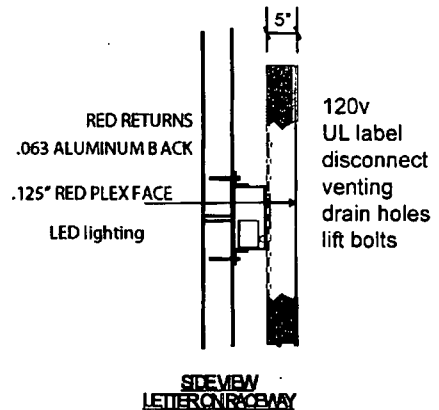

# REGAL STADIUM 14

Logo: Typical 5" dp, flush mt.  
 Lettering: Typical 5" deep, raceway mount.