



# City of Chicago



O2017-3754

## Office of the City Clerk Document Tracking Sheet

<b>Meeting Date:</b>	5/18/2017
<b>Sponsor(s):</b>	Arena (45)
<b>Type:</b>	Ordinance
<b>Title:</b>	Grant(s) of privilege in public way for Chicken Works and Salad Co. - sign
<b>Committee(s) Assignment:</b>	Committee on Transportation and Public Way

ORDINANCE  
CHICKEN WORKS AND SALAD CO.  
Acct. No. 343279 - 1  
Permit No. 1127763

*Be It Ordained by the City Council of the City of Chicago:*

SECTION 1. Permission and authority are hereby given and granted to CHICKEN WORKS AND SALAD CO., upon the terms and subject to the conditions of this ordinance to maintain and use two (2) sign(s) projecting over the public right-of-way attached to its premises known as 3658 W. Irving Park Rd..

Said sign structure(s) measures as follows; along W. Irving Park:

One (1) at six (6) feet in length, four (4) feet in height and twelve (12) feet above grade level.

Said sign structure(s) measures as follows; along N. Elston:

One (1) at six (6) feet in length, four (4) feet in height and twelve (12) feet above grade level.

The location of said privilege shall be as shown on prints kept on file with the Department of Business Affairs and Consumer Protection and the Office of the City Clerk.

Said privilege shall be constructed in accordance with plans and specifications approved by the Department of Transportation (Division of Project Development) and Zoning Department - Signs.

This grant of privilege in the public way shall be subject to the provisions of Section 10-28-015 and all other required provisions of the Municipal Code of Chicago.

The grantee shall pay to the City of Chicago as compensation for the privilege #1127763 herein granted the sum of one hundred seventy-five (\$175.00) per annum in advance.

A 25% penalty will be added for payments received after due date.

The permit holder agrees to hold the City of Chicago harmless for any damage, relocation or replacement costs associated with damage, relocation or removal of private property caused by the City performing work in the public way.

Authority herein given and granted for a period of five (5) years from and after 03/14/2017.

Alderman \_\_\_\_\_

John Arena 45<sup>th</sup> Ward

**SIGN TYPE** Double Face LightBox  
**BUSINESS NAME** Chicken Works and Salad Co  
**LOCATION** 3658 W Irving Park Rd / This lightbox is on Elston Ave

# DOUBLE FACE LIGHTBOX

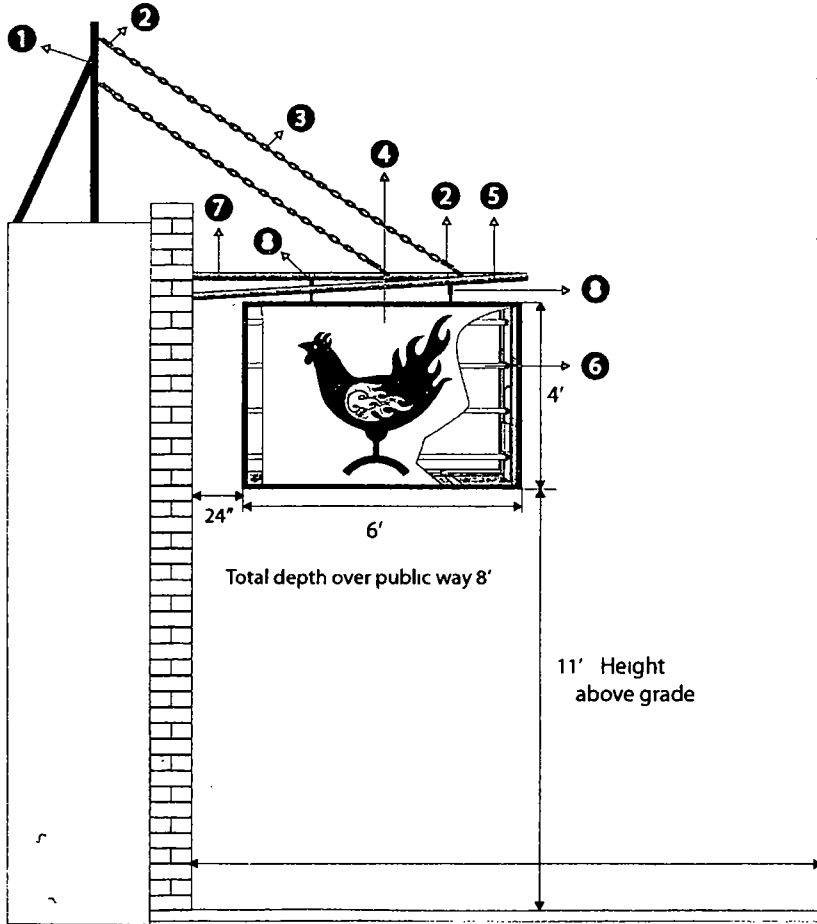

**DOUBLE FACE LIGHTBOX**

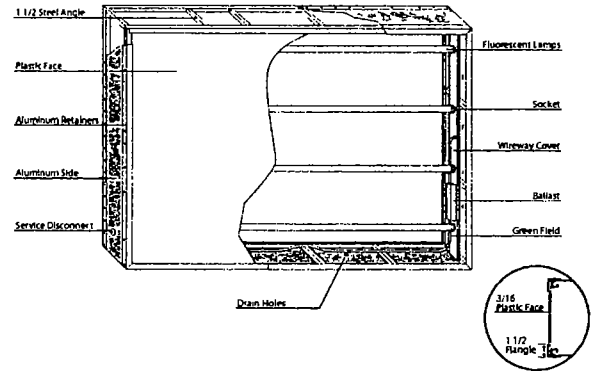

- ① 1 1/2" Angle Iron Roof Mount - A Frame
  - ② Turn Buckles
  - ③ Chain 80
  - ④ Lexon Face
  - ⑤ 1 1/2" Stiff Arm
  - ⑥ Florescent Lamp
  - ⑦ 2" Galvanized Pipe primed painted
  - ⑧ Swing
- 1 1/2" Angle Iron Around Interior Perimeter of Light Box

All material Noncombustible and fabricated with galvanized material capable of up to handelling 30 LBS win Load per foot



04/19/2017

Alderman **John Arena**  
Ward # **45**  
City of Chicago  
City Hall, Room **300**  
121 North LaSalle Street  
Chicago, Illinois 60602

Re: An ordinance to use and maintain a portion of the public right-of-way for **two (2) sign(s)** for  
**CHICKEN WORKS AND SALAD CO.**, adjacent to the premises known as **3658 W. Irving Park Rd.**

Dear Alderman **John Arena**:

The applicant referenced above has requested the use of the public right-of-way for a **sign(s)**. An ordinance has been prepared by the Department of Business Affairs and Consumer Protection – Small Business Center - Public Way Use Unit for presentation to the City Council. Because this request was made for properties located in your ward, as approved by you as per the attached, I respectfully request that you introduce the attached ordinance at the next City Council meeting.

If you have any questions regarding this ordinance, please contact Anthony Bertuca at (312) 744-5506.

**Department of Business Affairs and Consumer Protection**