



City of Chicago



O2020-5601

Office of the City Clerk

Document Tracking Sheet

Meeting Date:	11/16/2020
Sponsor(s):	Reilly (42)
Type:	Ordinance
Title:	Grant(s) of privilege in public way for Sheffield Properties of Illinois, Inc.
Committee(s) Assignment:	Committee on Transportation and Public Way

ORDINANCE
SHEFFIELD PROPERTIES OF ILLINOIS INC
Acct. No. 380838 - 1
Permit No. 1146991

Be It Ordained by the City Council of the City of Chicago.

SECTION 1. Permission and authority are hereby given and granted to SHEFFIELD PROPERTIES OF ILLINOIS INC, upon the terms and subject to the conditions of this ordinance to construct, install, maintain and use three (3) Security Camera(s) projecting over the public right-of-way for security purposes adjacent to its premises known as 940 N. Michigan Ave..

Said Security Camera(s) at N. Michigan measure(s):

Two (2) at point five four (.54) feet in length, point three nine (.39) feet in width and fourteen point two five (14.25) feet above grade level.

One (1) at point five four (.54) feet in length, point three nine (.39) feet in width and fourteen point two five (14.25) feet above grade level.

The location of said privilege shall be as shown on prints kept on file with the Department of Business Affairs and Consumer Protection and the Office of the City Clerk.

Said privilege shall be constructed in accordance with plans and specifications approved by the Department of Planning and Development and Department of Transportation (Division of Project Development).

This grant of privilege in the public way shall be subject to the provisions of Section 10-28-015 and all other required provisions of the Municipal Code of Chicago.

The grantee shall pay to the City of Chicago as compensation for the privilege #1146991 herein granted the sum of zero (\$.00) per annum in advance.

A 25% penalty will be added for payments received after due date.

The permit holder agrees to hold the City of Chicago harmless for any damage, relocation or replacement costs associated with damage, relocation or removal of private property caused by the City performing work in the public way.

Authority herein given and granted for a period of five (5) years from and after Date of Passage.

Alderman 

Brendan Reilly 42nd Ward

Security Cameras

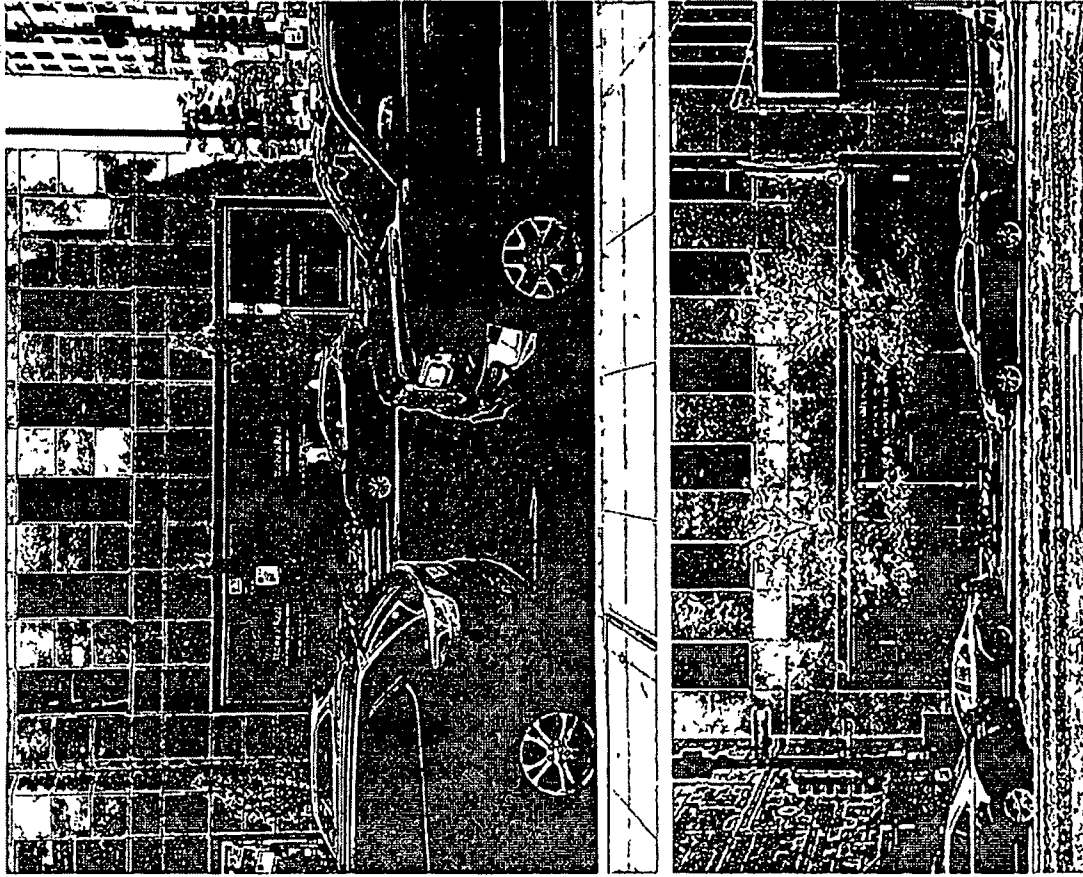

Existing Shelf

- Length of structure along public way
50 on Michigan
50 on Walton
- Height of shelf structure 14.3
- Depth of shelf structure 9
- Height above grade 14.3
- Total depth over public way 9

XNV-8080RSA

Camera Type SMP Network Stainless IR Dome Camera
Camera Size 6.38 wide x 4.74 tall

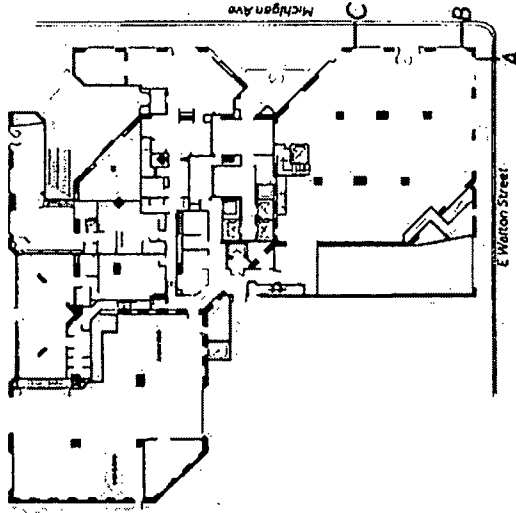
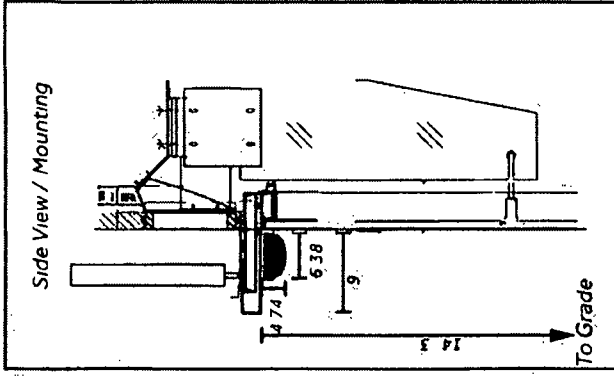
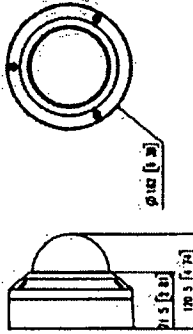
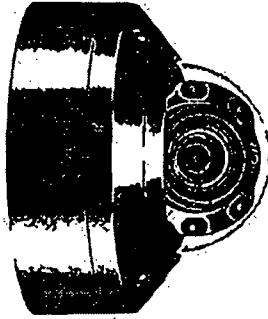

	Designated by to Franklin Partners 1800 AlFrapelli P.O. Box 100 security camera proof	Date 9/15/2020	Signature Date
© 2014 Custom Sign Consultants Inc. All rights reserved. Custom Sign Consultants Inc. reserves all rights of reproduction and all copyrights in designs, materials and data on these papers created by Custom Sign Consultants Inc. as well as the preliminary design and any incidental work made hereon. All other rights reserved. Custom Sign Consultants Inc. and its affiliates. Unauthorized copying, reverse engineering, competing and creating derivative works are expressly forbidden. No part of the content may be otherwise or subsequently reproduced, disseminated, published or translated in any form or by any means except with the prior written permission of and with express attribution to Custom Sign Consultants Inc. Copyright infringement is a violation of federal law, subject to criminal and civil penalties.			

Signature states that above proof is accepted and client is authorizing to produce the specified



Department of Business Affairs and Consumer Protection
Small Business Center - Public Way Use Unit
City Hall - 121 N. LaSalle Street, Room 800 • Chicago, IL 60602
312-74-GOBIZ / 312-744-6249 • (312) 744-1944 (TTY)
<http://www.cityofchicago.org/bacp>

11/16/2020

Alderman **Brendan Reilly**
Ward # 42
City of Chicago
City Hall, Room 300
121 North LaSalle Street
Chicago, Illinois 60602

Re: An ordinance to use and maintain a portion of the public right-of-way for **three (3) security camera(s)** for **SHEFFIELD PROPERTIES OF ILLINOIS INC**, adjacent to the premises known as **940 N. Michigan Ave.**.

Dear Alderman **Brendan Reilly**:

The applicant referenced above has requested the use of the public right-of-way for a **security camera(s)**. An ordinance has been prepared by the Department of Business Affairs and Consumer Protection – Small Business Center - Public Way Use Unit for presentation to the City Council. Because this request was made for properties located in your ward, as approved by you as per the attached, I respectfully request that you introduce the attached ordinance at the next City Council meeting.

If you have any questions regarding this ordinance, please contact Anthony Bertuca at (312) 744-5506.

Department of Business Affairs and Consumer Protection