



City of Chicago



O2017-8968

Office of the City Clerk

Document Tracking Sheet

Meeting Date:	12/13/2017
Sponsor(s):	Silverstein (50)
Type:	Ordinance
Title:	Awning(s) for Music House, Inc.
Committee(s) Assignment:	Committee on Transportation and Public Way

ORDINANCE
MUSIC HOUSE INC
Acct. No. 5106 - 1
Permit No. 1129797

Be It Ordained by the City Council of the City of Chicago:

SECTION 1. Permission and authority are hereby given and granted to MUSIC HOUSE INC, upon the terms and subject to the conditions of this ordinance to construct, install, maintain and use one (1) Awning(s) projecting over the public right-of-way adjacent to its premises known as 2925 W. Devon Ave..

Said Awning(s) at W. Devon Avenue measure(s):

One (1) at sixty (60) feet in length, and two (2) feet in width for a total of one hundred twenty (120) square feet.

The location of said privilege shall be as shown on prints kept on file with the Department of Business Affairs and Consumer Protection and the Office of the City Clerk.

Said privilege shall be constructed in accordance with plans and specifications approved by the Zoning Department - Signs.

This grant of privilege in the public way shall be subject to the provisions of Section 10-28-015 and all other required provisions of the Municipal Code of Chicago.

The grantee shall pay to the City of Chicago as compensation for the privilege #1129797 herein granted the sum of eighty-five (\$85.00) per annum in advance.

A 25% penalty will be added for payments received after due date.

The permit holder agrees to hold the City of Chicago harmless for any damage, relocation or replacement costs associated with damage, relocation or removal of private property caused by the City performing work in the public way.

Authority herein given and granted for a period of five (5) years from and after Date of Passage.

Alderman

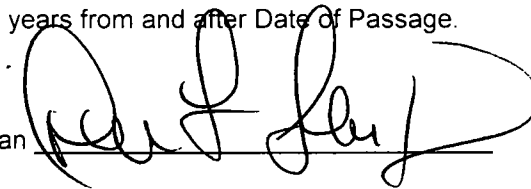

Debra L. Silverstein 50th Ward

Awning w/ Decals • Music House • Chicago • IL



AWNING WITH TUBULAR ALUMINUM SKELETON FABRICATE AND INSTALL

NON ILLUMINATED

QUANTITY 1

OVERALL HEIGHT OF AWNING 48 OVERALL LENGTH OF AWNING 720 OVERALL DEPTH OF AWNING 24

AWNING TO BE AWNMAX VINYL FABRIC COLOR TBD BY CLIENT

TEXT AND GRAPHICS FDC 3M OPAQUE VINYL

COLOR TBD BY CLIENT

AWNING TO BE DIRECTLY MOUNTED TO WALL WITH 3/8 FASTENERS

AWNING FACE TO READ

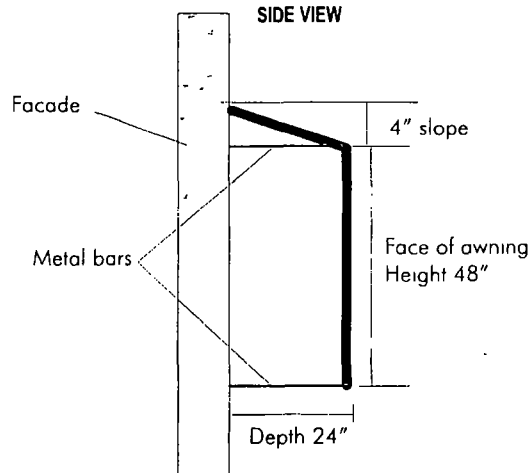

tfasigns
 5500 N Kedzie Ave Chicago IL 60625
 773 267 6007 | sales@tfasigns.com

Client Name
 Music House

Location
 2925 W Devon
 Chicago IL

Start Date 04/21/2017
Last Revision 07/25/2017
Job# 00000
Drawing# 00000a v1 s1 / e1
Page 2 of 3

• Client Approval
 • Landlord Approval

Sales Rep
 Andrew Oh
Designer
 Peter Boateng



12/13/2017

Alderman **Debra L. Silverstein**
Ward # 50
City of Chicago
City Hall, Room 300
121 North LaSalle Street
Chicago, Illinois 60602

Re: An ordinance to use and maintain a portion of the public right-of-way for **one (1) awning(s)** for **MUSIC HOUSE INC.**, adjacent to the premises known as **2925 W. Devon Ave.**.

Dear Alderman **Debra L. Silverstein**:

The applicant referenced above has requested the use of the public right-of-way for a **awning(s)**. An ordinance has been prepared by the Department of Business Affairs and Consumer Protection – Small Business Center - Public Way Use Unit for presentation to the City Council. Because this request was made for properties located in your ward, as approved by you as per the attached, I respectfully request that you introduce the attached ordinance at the next City Council meeting.

If you have any questions regarding this ordinance, please contact Anthony Bertuca at (312) 744-5506.

Department of Business Affairs and Consumer Protection