



City of Chicago



O2016-1022

Office of the City Clerk

Document Tracking Sheet

Meeting Date:	2/10/2016
Sponsor(s):	Waguespack (32)
Type:	Ordinance
Title:	Grant(s) of privilege in public way for Byline Bank
Committee(s) Assignment:	Committee on Transportation and Public Way

ORDINANCE
BYLINE BANK
Acct. No. 398078 - 12
Permit No. 1120803

Be It Ordained by the City Council of the City of Chicago:

SECTION 1. Permission and authority are hereby given and granted to BYLINE BANK, upon the terms and subject to the conditions of this ordinance to maintain and use two (2) sign(s) projecting over the public right-of-way attached to its premises known as 3401 N. Western Ave..

Said sign structure(s) measures as follows; along N. Western Avenue:

One (1) at eleven point one seven (11.17) feet in length, point five (.5) feet in height and fourteen point five eight (14.58) feet above grade level.

Said sign structure(s) measures as follows; along N. Western Avenue:

One (1) at nine (9) feet in length, four point eight three (4.83) feet in height and fifteen point six seven (15.67) feet above grade level.

The location of said privilege shall be as shown on prints kept on file with the Department of Business Affairs and Consumer Protection and the Office of the City Clerk.

Said privilege shall be constructed in accordance with plans and specifications approved by the Department of Transportation (Division of Project Development) and Zoning Department - Signs.

This grant of privilege in the public way shall be subject to the provisions of Section 10-28-015 and all other required provisions of the Municipal Code of Chicago.

The grantee shall pay to the City of Chicago as compensation for the privilege #1120803 herein granted the sum of four hundred (\$400.00) per annum in advance.

A 25% penalty will be added for payments received after due date.

The permit holder agrees to hold the City of Chicago harmless for any damage, relocation or replacement costs associated with damage, relocation or removal of private property caused by the City performing work in the public way.

Authority herein given and granted for a period of five (5) years from and after Date of Passage.

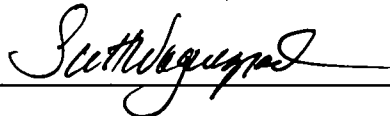
Alderman 
Scott Waguespack 32nd Ward

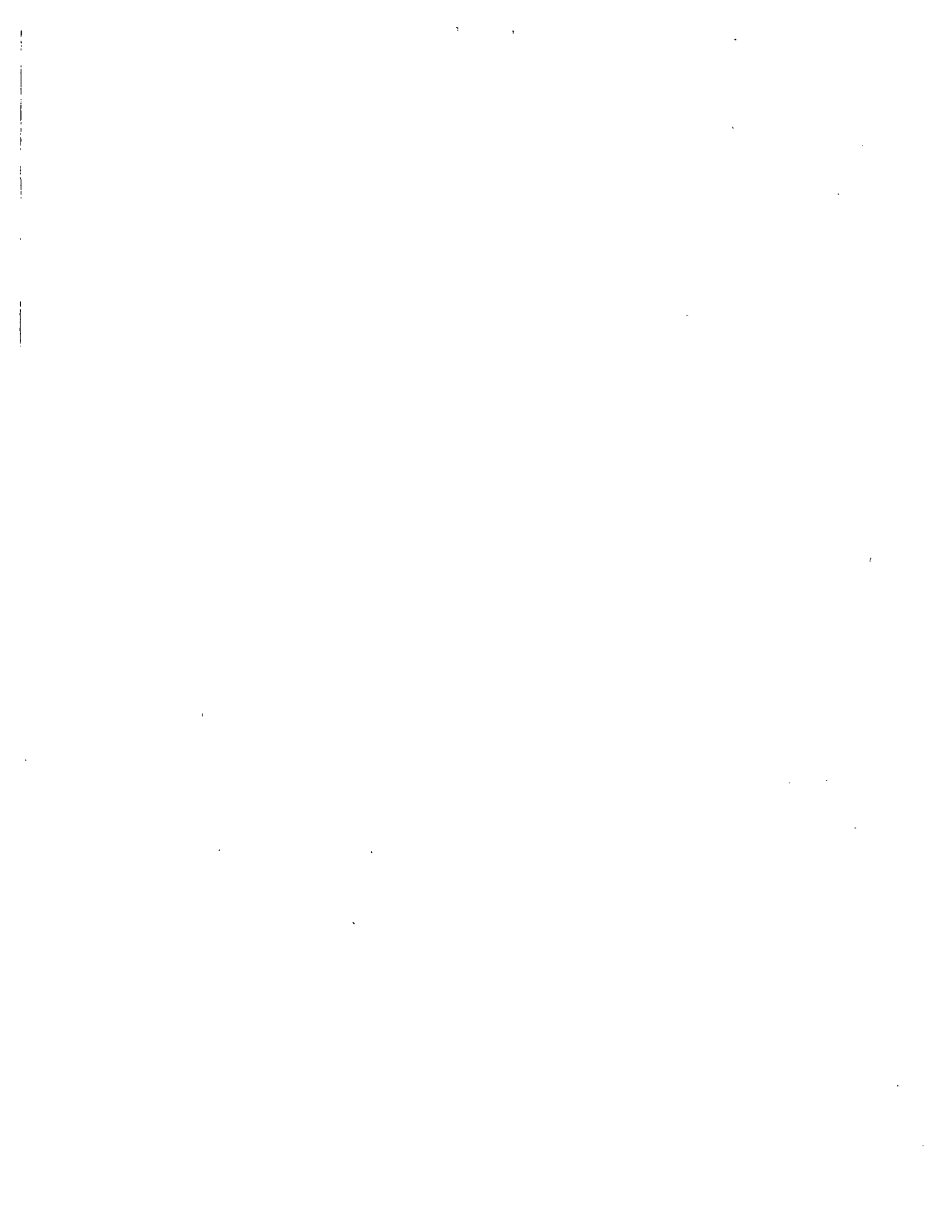

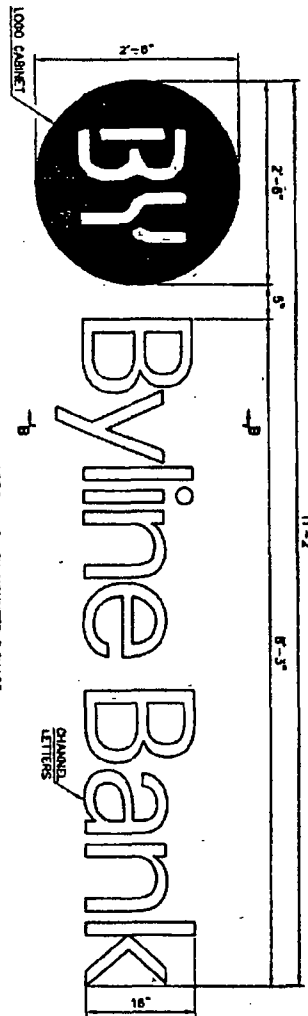

SEE SHEET 1 FOR RACEWAY MOUNTED SIGNAGE ATTACH OPTIONS
SEE SHEET 1 FOR NOTES

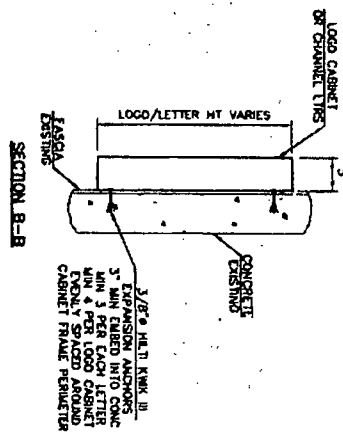
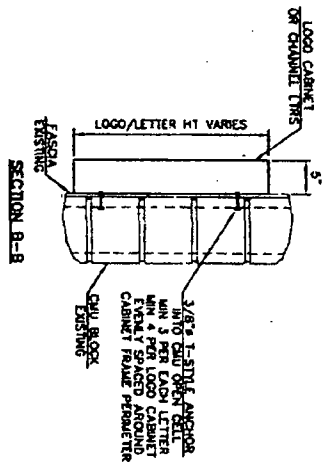
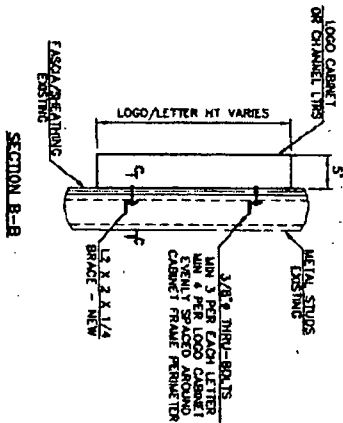

METAL STUDS SHALL NOT BE RESPONSIBLE FOR THE INSTALLATION OF THE SIGNAGE. THE INSTALLER SHALL BE RESPONSIBLE FOR THE PROPERLY FASTENING THE ANCHOR BRACING TO THE EXISTING FRAME USING STANDARD CONSTRUCTION PRACTICES. EXISTING WALL, STUDS AND/OR BRACE SHALL BE REINFORCED IF THE WALL CONSTRUCTION IS WOOD FRAME LIMITED TO METAL 2x4 WOOD BLOCKING MAY BE USED INSTEAD OF THE WOOD BRACING.

CAST-IN-PLACE CONCRETE SHALL BE 3/4" MINIMUM CLEARANCE FROM THE ANCHORS. THE ANCHORS SHALL BE FULLY ENCASED AND THE ANCHORS SHALL BE FULLY ENCASED IN THE CAST-IN-PLACE CONCRETE. THE ANCHORS SHALL BE FULLY ENCASED IN THE CAST-IN-PLACE CONCRETE. THE ANCHORS SHALL BE FULLY ENCASED IN THE CAST-IN-PLACE CONCRETE. THE ANCHORS SHALL BE FULLY ENCASED IN THE CAST-IN-PLACE CONCRETE.

CONCRETE SHALL BE 3/4" MINIMUM CLEARANCE FROM THE ANCHORS. THE ANCHORS SHALL BE FULLY ENCASED AND THE ANCHORS SHALL BE FULLY ENCASED IN THE CAST-IN-PLACE CONCRETE. THE ANCHORS SHALL BE FULLY ENCASED IN THE CAST-IN-PLACE CONCRETE. THE ANCHORS SHALL BE FULLY ENCASED IN THE CAST-IN-PLACE CONCRETE.

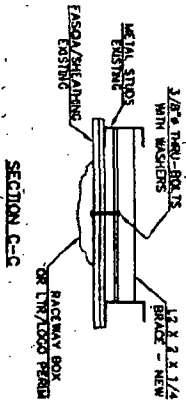

JAMES E. WRIGHT JR.
Professional Engineer
No. 1111111111
State of Illinois
Expires 11-30-16
11-30-16

Project # 150523	Drawn By CRS
Dwg # CA21248	Date: 07/28/15
Scale: 1"=1'-0"	Sheet: 2 of 2

PREPARED FOR:
MLE, Inc
1800 East Avenue - FIA (Crown Village) IL 60617
Byline Bank Sign 2'6 X 11'-2" Mounted Logo/Letters
Chicago, Illinois Area

CORNERSTONE ENGINEERING, INC.
1100 W. Echo Bluff Drive - Maryville, TN 37601
(615) 713-2668 - www.CSeng.com

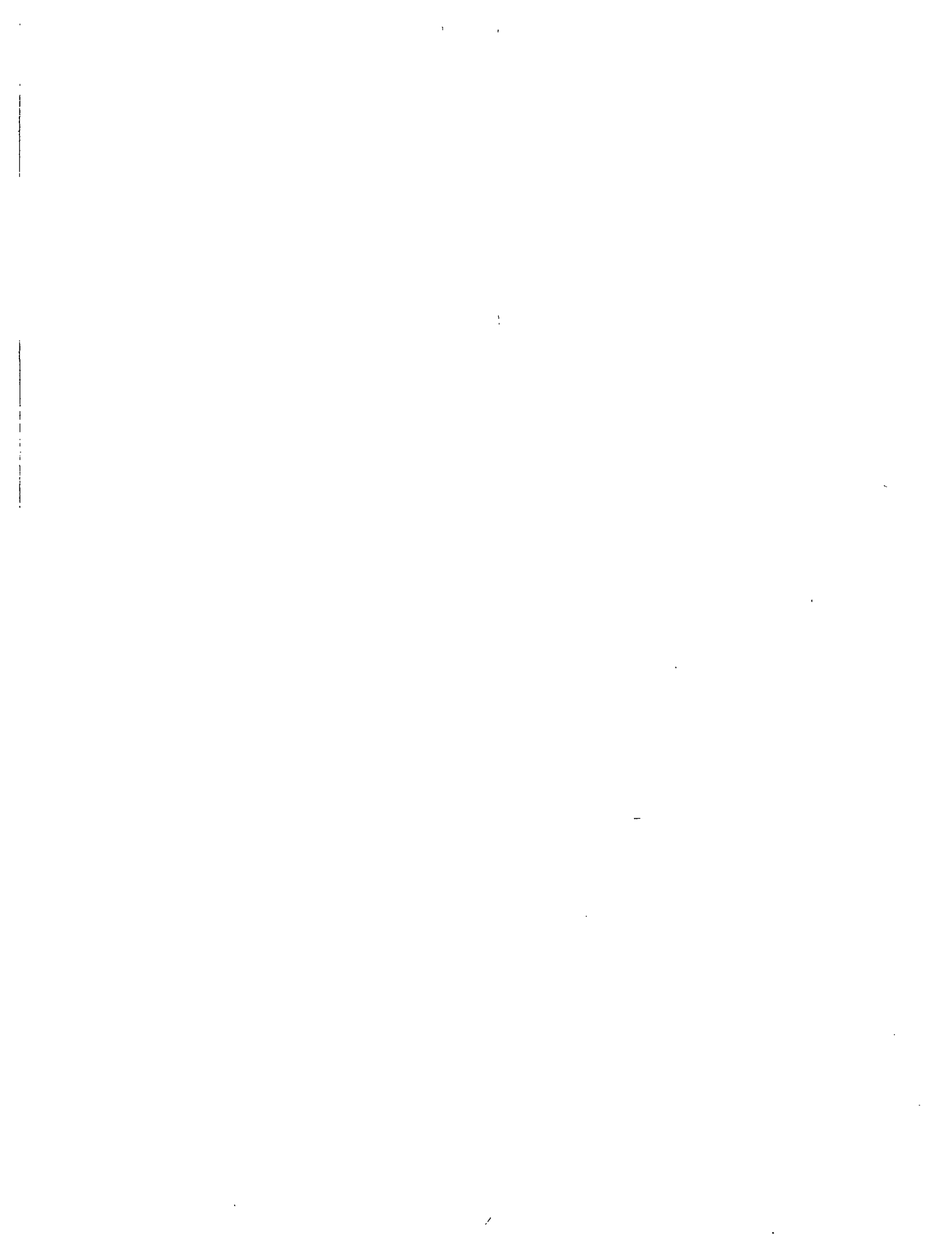



Site Name: Roscoe
Site Number: 14
3401 North Western Ave Chicago, IL



Sign #1 - Double-Faced Pylon - 15'8" OAH - Qty 1

Fabricated aluminum cabinet with bullnosed top and bottom as shown in drawing. Logo applied on both sides.

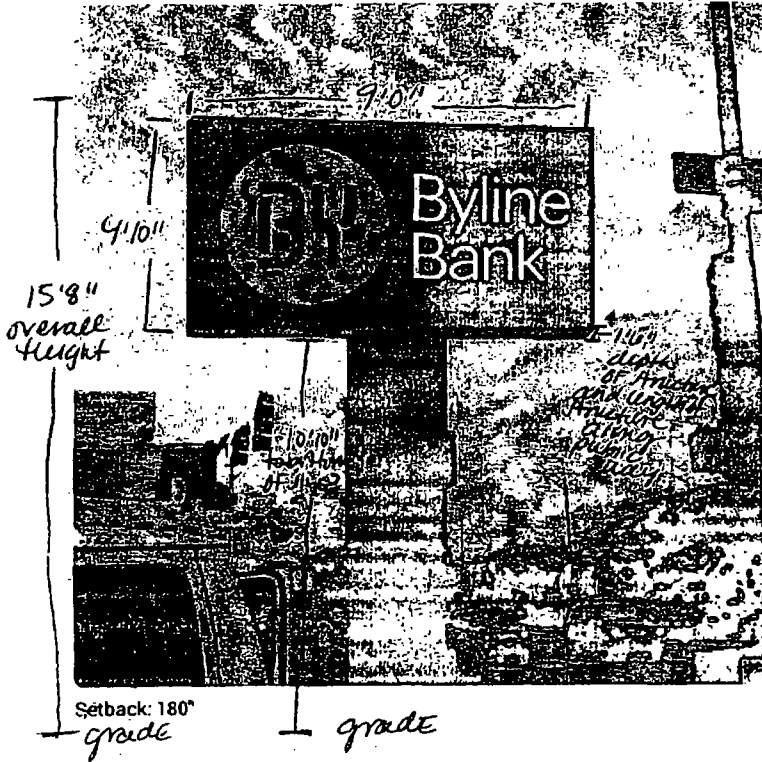

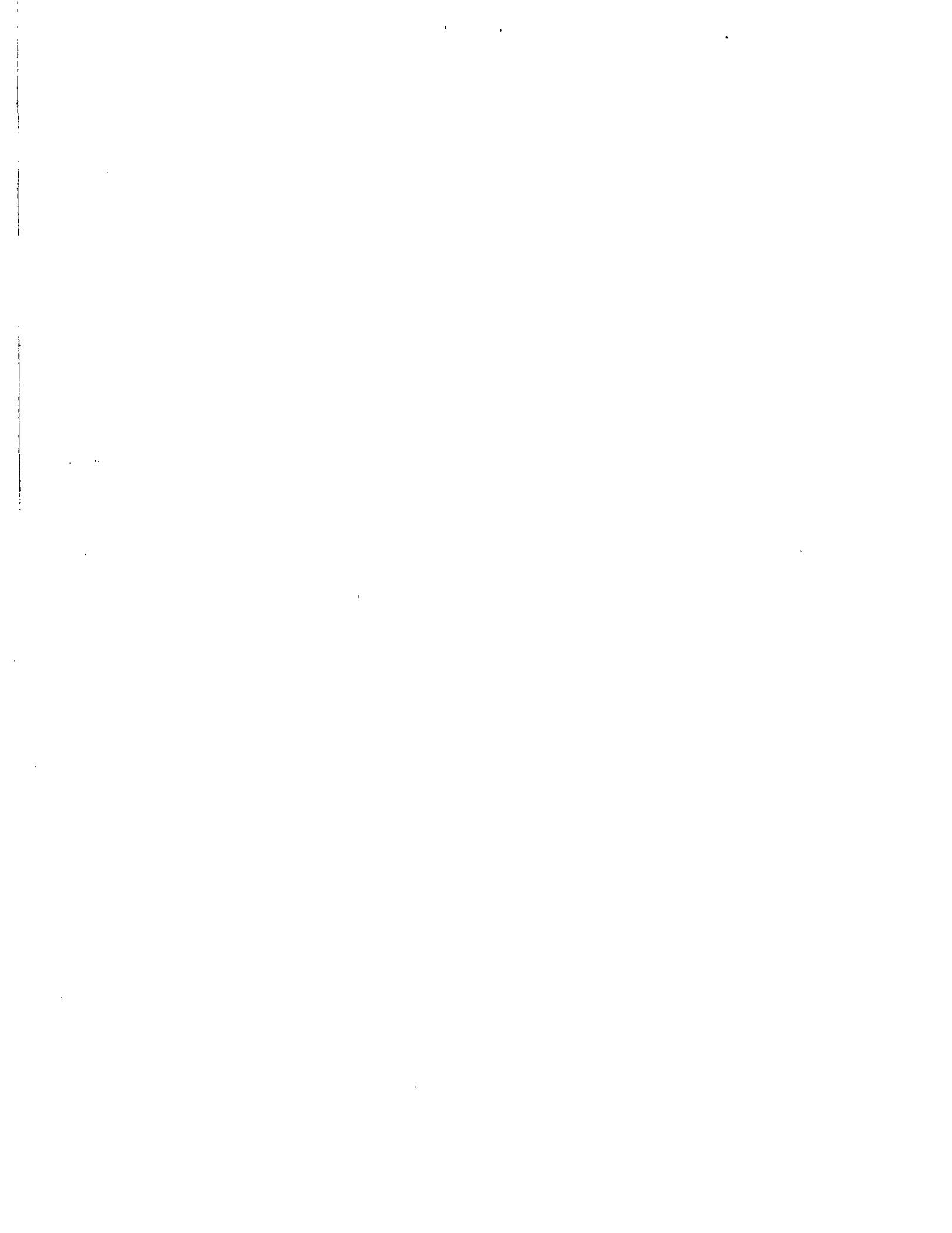



02/10/2016

Alderman **Scott Waguespack**
Ward # **32**
City of Chicago
City Hall, Room **300**
121 North LaSalle Street
Chicago, Illinois 60602

Re: An ordinance to use and maintain a portion of the public right-of-way for **two (2) sign(s)** for **BYLINE BANK**, adjacent to the premises known as **3401 N. Western Ave.**.

Dear Alderman **Scott Waguespack**:

The applicant referenced above has requested the use of the public right-of-way for a **sign(s)**. An ordinance has been prepared by the Department of Business Affairs and Consumer Protection – Small Business Center - Public Way Use Unit for presentation to the City Council. Because this request was made for properties located in your ward, as approved by you as per the attached, I respectfully request that you introduce the attached ordinance at the next City Council meeting.

If you have any questions regarding this ordinance, please contact Anthony Bertuca at (312) 744-5506.

Department of Business Affairs and Consumer Protection

