



City of Chicago



O2017-4714

Office of the City Clerk

Document Tracking Sheet

Meeting Date:	6/22/2017
Sponsor(s):	Waguespack (32)
Type:	Ordinance
Title:	Grant(s) of privilege in public way for Aldi, Inc. No. 64 - sign - Privilege No. 1127557
Committee(s) Assignment:	Committee on Transportation and Public Way

ORDINANCE
ALDI INC #64
Acct. No. 5273 - 9
Permit No. 1127557

Be It Ordained by the City Council of the City of Chicago:

SECTION 1. Permission and authority are hereby given and granted to ALDI INC #64, upon the terms and subject to the conditions of this ordinance to maintain and use two (2) sign(s) projecting over the public right-of-way attached to its premises known as 1767 N. Milwaukee Ave..

Said sign structure(s) measures as follows; along N MILWAUKEE AVE:
One (1) at six point two five (6.25) feet in length, seven point four two (7.42) feet in height and twelve (12) feet above grade level.
One (1) at sixteen (16) feet in length, four (4) feet in height and fourteen (14) feet above grade level.

The location of said privilege shall be as shown on prints kept on file with the Department of Business Affairs and Consumer Protection and the Office of the City Clerk.

Said privilege shall be constructed in accordance with plans and specifications approved by the Department of Transportation (Division of Project Development) and Zoning Department - Signs.

This grant of privilege in the public way shall be subject to the provisions of Section 10-28-015 and all other required provisions of the Municipal Code of Chicago.

The grantee shall pay to the City of Chicago as compensation for the privilege #1127557 herein granted the sum of six hundred (\$600.00) per annum in advance.

A 25% penalty will be added for payments received after due date.

The permit holder agrees to hold the City of Chicago harmless for any damage, relocation or replacement costs associated with damage, relocation or removal of private property caused by the City performing work in the public way.

Authority herein given and granted for a period of five (5) years from and after Date of Passage.

Alderman _____

Scott Waguespack 32nd Ward

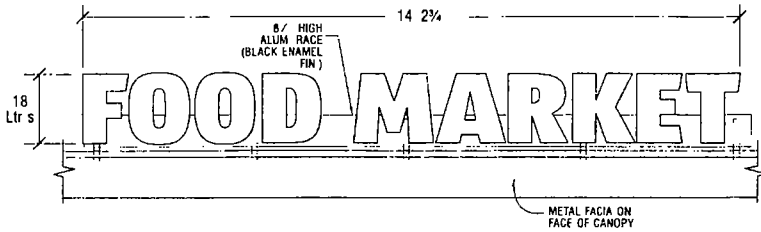

B LED Illum d Race Mount Letters on Canopy
 scale 1/2" = 1' 0"
 ONE(1) SET REQ'D
 WHITE PLEX FACES GRAY TRIM CAP & GRAY PTD
 ALUM CHANNEL (RETURNS)
 WHITE LED ILLUM

- LEGEND**
- 1 TRIM CAP BLACK
 - 2 120 VOLTS 1/2" WIRE
 - 3 3/4" ALUMINUM RETURN BLACK
 - 4 TERMINAL BLOCK
 - 5 TRANSFORMER CLASS 12V
 - 6 FUSIBLE RECIPER
 - 7 SAFETY SWITCH
 - 8 120V ALUMINUM BRACE
 - 9 120V PRIMARY NO. 12 THHN
 - 10 STRANDED WIRE 1/2" AMP CIRCUIT
 - 11 FLEXIBLE WEATHERPOOR
 - 12 CONDUIT PER LOCAL CODE
 - 13 SEALANT SEAL ALL PENETRATIONS
 - 14 1/2" APPROVED STANDARD DOWLING
 - 15 ALUM (40 D) SCHEDULE 40 ACCESS, E.C.
 - 16 1 1/4" X 1/4" X 3/16" GALV L. FRAMING
 - 17 1/4" DRAIN HOLE
 - 18 LED CIRCUIT BOARD
 - 19 LED STENCIL
 - 20 J BOX

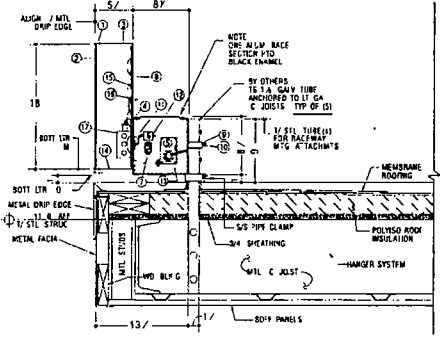

Letters w/ Race on Canopy SECTION
 CAULK PENETRATIONS scale 1" = 1' 0"

C Standard Lexan Face Illum d Wall Sign
 ONE(1) req'd scale 1/4" = 1' 0"

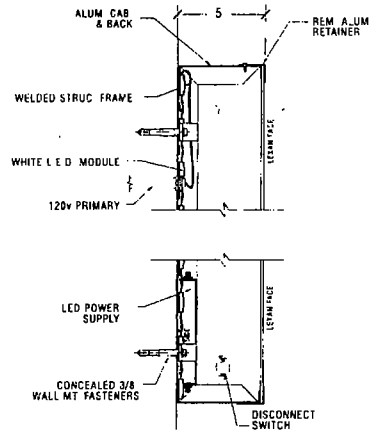

DATE	REVISION
2/15/17	UPDATING 2002 MARSHALL LETTERS FROM WALL TO CANOPY
3/20/17	REVISED MOUNTING OF METAL STRUC
3/21/17	REVISED PER MAIL FOR GMA
3/22/17	REVISED PER MAIL FOR GMA
3/23/17	REVISED PER MAIL FOR GMA
3/24/17	REVISED PER MAIL FOR GMA
4/3/17	REVISED PER MAIL FOR GMA
4/7/17	REVISED PER MAIL FOR GMA

CUSTOMER APPROVAL _____ **DATE** _____

This sheet is the property of Doyle Sign Co. and its use is limited to the project specified. No part of this sheet may be reproduced or transmitted in any form or by any means electronic, mechanical, photocopying, recording, or by any information storage and retrieval system without the expressed written consent of Doyle Sign Co. The rights to this design may be protected.

CLIENT	ALDI
ADDRESS	1748 1769 N MILWAUKEE AVE & 1733 1745 N LEAVITT ST
CITY	CHICAGO STATE IL DESIGNER KM SALESPERSON TD
DRWG NO	14/05 SCALE NOTED DATE 07.16.2015 SHEET NO 4

VDoyle 232PublicDesign\ALDIDCHICAGO MILWAUKEE AVE\ALDI CHICAGO MILWAUKEE AVE 4 7 17.cdw



Department of Business Affairs and Consumer Protection
Small Business Center - Public Way Use Unit
City Hall - 121 N. LaSalle Street, Room 800 • Chicago, IL 60602
312-74-GOBIZ / 312-744-6249 • (312) 744-1944 (TTY)
<http://www.cityofchicago.org/bacp>

05/24/2017

Alderman Scott Waguespack
Ward # 32
City of Chicago
City Hall, Room 300
121 North LaSalle Street
Chicago, Illinois 60602

Re: An ordinance to use and maintain a portion of the public right-of-way for **two (2) sign(s)** for **ALDI INC #64**, adjacent to the premises known as **1767 N. Milwaukee Ave.**.

Dear Alderman **Scott Waguespack**:

The applicant referenced above has requested the use of the public right-of-way for a **sign(s)**. An ordinance has been prepared by the Department of Business Affairs and Consumer Protection – Small Business Center - Public Way Use Unit for presentation to the City Council. Because this request was made for properties located in your ward, as approved by you as per the attached, I respectfully request that you introduce the attached ordinance at the next City Council meeting.

If you have any questions regarding this ordinance, please contact Anthony Bertuca at (312) 744-5506.

Department of Business Affairs and Consumer Protection