



City of Chicago



Or2013-661

Office of the City Clerk

Document Tracking Sheet

Meeting Date:	11/13/2013
Sponsor(s):	Sposato (36)
Type:	Order
Title:	Issuance of permits for sign(s)/signboard(s) at 6420 W Fullerton Ave
Committee(s) Assignment:	Committee on Zoning, Landmarks and Building Standards

ORDERED, That the Commissioner of Buildings is hereby directed to issue a sign permit to Corporate ID Solutions, 5563 N. Elston Ave, Chicago, IL 60630, for the erection of a sign/signboard over 24 feet in height and/or over 100 square feet (in area of one face) at:

Babies R Us/Toys R Us-6420 W. Fullerton Chicago, IL 60707

Dimensions: length, 28 feet; height, 6 feet
Height above grade/roof to top of sign: 14 feet
Total Square Foot Area: 168 square feet

To be legal, such sign(s) must comply with all applicable provisions of Title 17, to the Chicago Zoning Ordinance, and all other applicable provisions of the Municipal Code for the city of Chicago governing the construction and maintenance of signs, billboards, signboards and related structures.

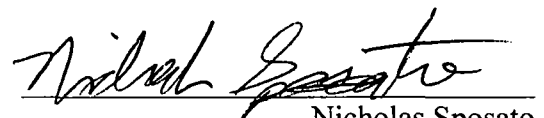
Nicholas Sposato
Alderman, 36th Ward

CITY OF CHICAGO
DEPARTMENT OF BUILDINGS
Sign Permit Application

APPROVAL NUMBER	APPLICATION NUMBER 100512117	ANNUAL FEE	WORK CODE	DRAWINGS ATTACHED <input type="checkbox"/> YES <input type="checkbox"/> NO
DATE OF APPLICATION 10/04/2013			TYPE OF SIGN FLAT OR BOX	
ADDRESS OF SIGN 6420 W FULLERTON AVE, 60707-			LENGTH	PT. 28
BUILDING			IN.	HEIGHT
ORIGINAL PERMIT NUMBER			FT. 6	IN.
TYPE OF PERMIT NEW CONSTRUCTION (SIGN)			AREA	SQ. FT. 168
PAYER OF ANNUAL INSPECTION MANAGER, STORE 6420 W FULLERTON AVE CHICAGO, IL 60707 (773)413-5005			WEIGHT	LBS. 518
SIGN MANUFACTURER ICON			SIGN HEIGHT ABOVE GRADE/ROOF FT. 14	
ADDRESS WHERE SIGN CAN BE SEEN PRIOR TO ERECTION			SHAPE OF SIGN REGULAR	
TICKET NUMBER 0			SIGN WILL READ BABIES R US	
REINSPECTION CONTROL NUMBER			NO. OF LAMPS 100	
TYPE OF SUPPORT FOR SIGN BUILDING			TOTAL WATTAGE 340	
SIGN BOARD SUPPORT MEMBERS OTHER			TYPE OF LAMP OTHER	
ANNUAL FEE			NO. OF BALLAST/TRANSFORMERS 9	
CONSTRUCTION FEE 200.00			INPUT OF TRANSFORMERS	
1017 B FEE			CONTRACTOR WILL INSTALL <input checked="" type="checkbox"/> PERDERS <input type="checkbox"/> CUSTOMER LEADS <input type="checkbox"/>	
TOTAL FEE 200.00			TYPE OF SWITCH KNIFE	
AMOUNT PAID 200.00			LOCATION OF SWITCH OUTSIDE SIGN	
BALANCE DUE			SIGN LOCATION BABIES R US SIGNAGE	
Check # for Zoning				
Check # for DCAP				

The undersigned certify that the statements in this application are true and correct and that all work done under the proposed permit will conform to the requirements of the Chicago Municipal Code

REG. NO. E93308	BOND. NO.	REG. NO. N93077
BLBCT CONTR LITE ZONE ELECTRIC	SIGN ERECTOR CORP.ID SOLUTIONS INC	SIGNER
ADDRESS 7943 N. KENNETH SKOKIE, IL 60076-	ADDRESS 5563 N ELSTON AVE CHICAGO X IL, 60630	
SUPERVISOR SIGNATURE	SIGNATURE <i>[Signature]</i>	

The permit issued on this application will authorize only signs here applied for. If other signs are to be erected they must be covered by additional permits

City of Chicago
 Rahm Emanuel, Mayor



Department of Buildings
 Michael Merchant, Commissioner

TYPE OF BUSINESS COM ENTERTAIN Other: _____ Name: TOYS R US LIC #: _____ Renewal Date: _____		SIGN BOND REQUIRED? <input checked="" type="checkbox"/> YES	
		COUNCIL ORDER REQUIRED <input checked="" type="checkbox"/> YES	
Projects Over: <input checked="" type="checkbox"/> Private Property <input checked="" type="checkbox"/> Public Way Grant Permit #: _____ <input checked="" type="checkbox"/> Planned Development/Manufacturing PMD/PD#: PD-127 Zoning District: OTHER Other: PD127		IS SPECIAL PERMISSION REQUIRED FROM CHIEF ELECTRICAL <input checked="" type="checkbox"/> YES IF YES, ATTACH LETTER OF REQUEST	
TYPE OF SIGN: <input type="checkbox"/> ADVERTISING <input checked="" type="checkbox"/> ILLUMINATE <input type="checkbox"/> MOVABLE <input checked="" type="checkbox"/> BUSINESS <input type="checkbox"/> FLASHING		TIME STAMP	
TOTAL STREET FRONTAGE OF LOT (IN FEET) _____ 1,400			
TOTAL AREA OF NEW SIGN (SQ. FT.) _____ 168			
TOTAL AREA OF ALL SIGNS ON LOT (SQ. FT.) _____ 130			
HEIGHT OF SIGN ABOVE GRADE (TO TOP) _____ 20ft in			
DISTANCE OF CURB LINE OUTER EDGE (ft) _____ 350		SIGN CLERK	APPROVED FOR PERMIT
DISTANCE OF STRUCTURE INNER EDGE (ft) _____ 351			
DISTANCE FROM (ft): A. PUBLIC PARK (OVER 10 ACRES) _____ 1,000 B. EXPRESSWAY (IF LESS THAN 1,000 FT.) _____ 1,000 C. RESIDENCE DISTRICT (ADVERTISING SIGNS ONLY) _____ 500		REMARKS	
IF REPLACEMENT SIGN OR CHANGE OF FACE, WHAT DOES THE EXISTING SIGN READ? Original Payee: _____			
Landmark Hold: <input type="checkbox"/> Status: _____			
ZONING (OFFICE USE ONLY)			

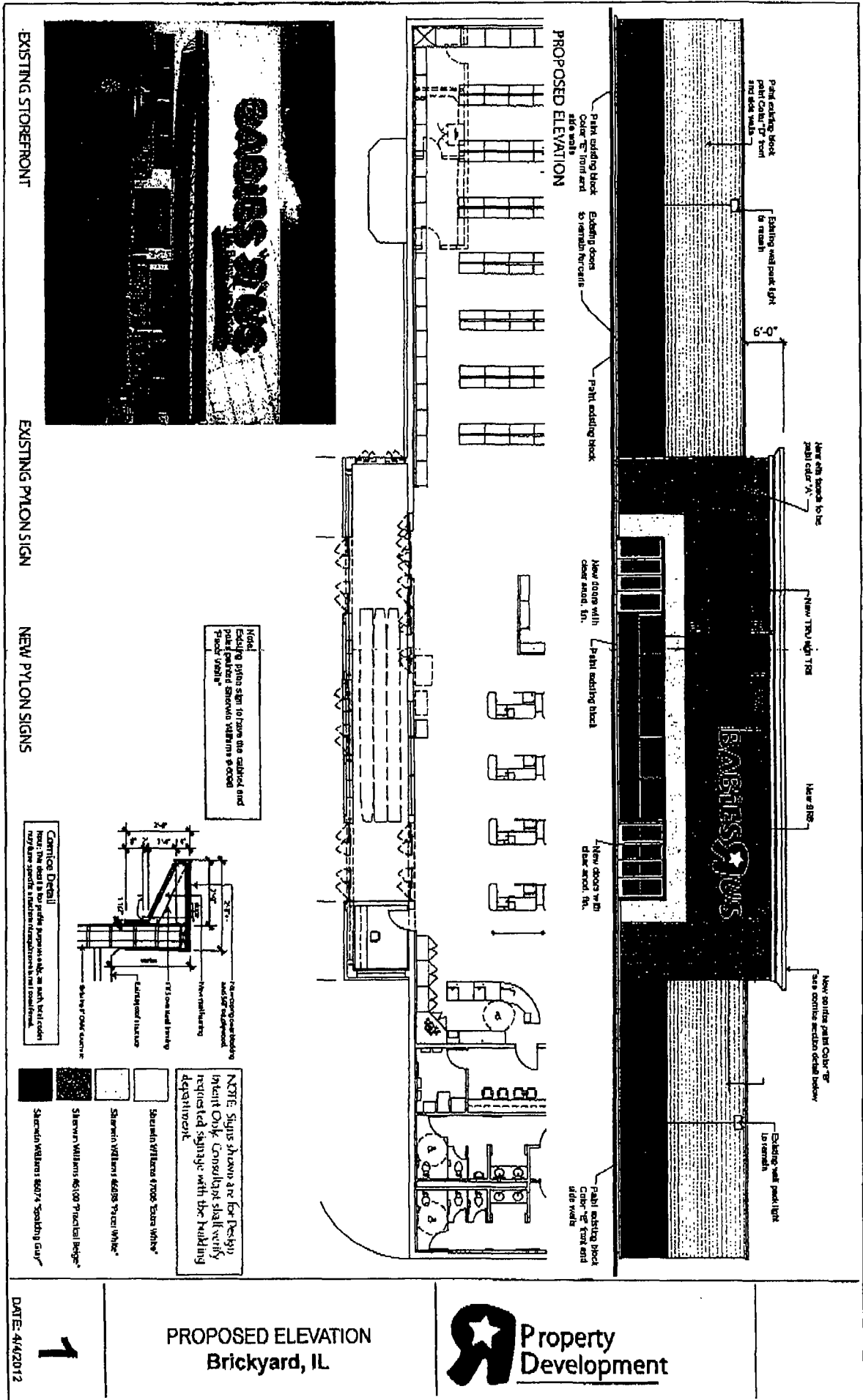

EXISTING STORERFRONT

EXISTING PYLON SIGN

NEW PYLON SIGNS

Color Key
 The color key for the proposed signs is as follows:
 1. Sherwin Williams 6010P "Practical Beige"
 2. Sherwin Williams 6700B "Egg White"
 3. Sherwin Williams 6700A "Egg White"
 4. Sherwin Williams 6010P "Practical Beige"

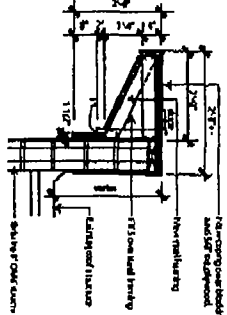

NOTE: Signs shown are for Design Intent Only. Consultant shall verify requested signage with the building department.

PROPOSED ELEVATION
 Brickyard, IL



DATE: 4/4/2012

1

EXTERIOR ELEVATION - DEMOLITION

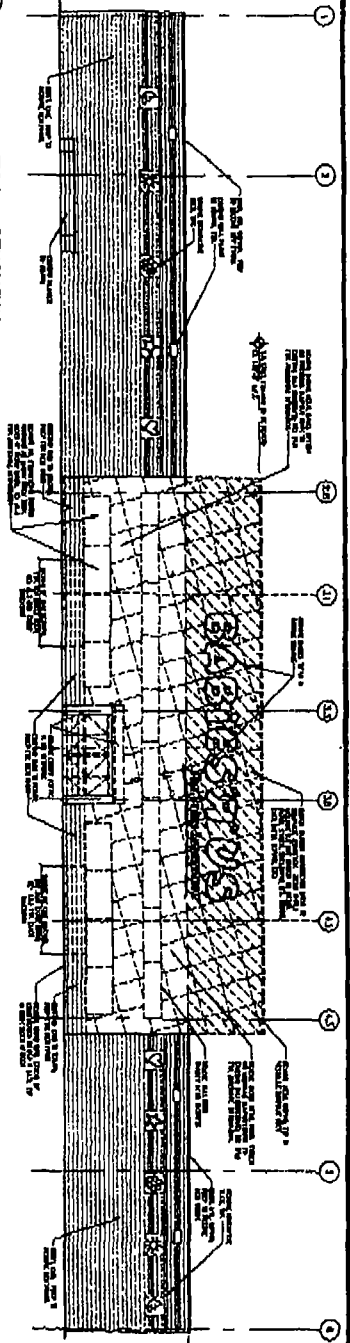

EXTERIOR ELEVATION - NEW

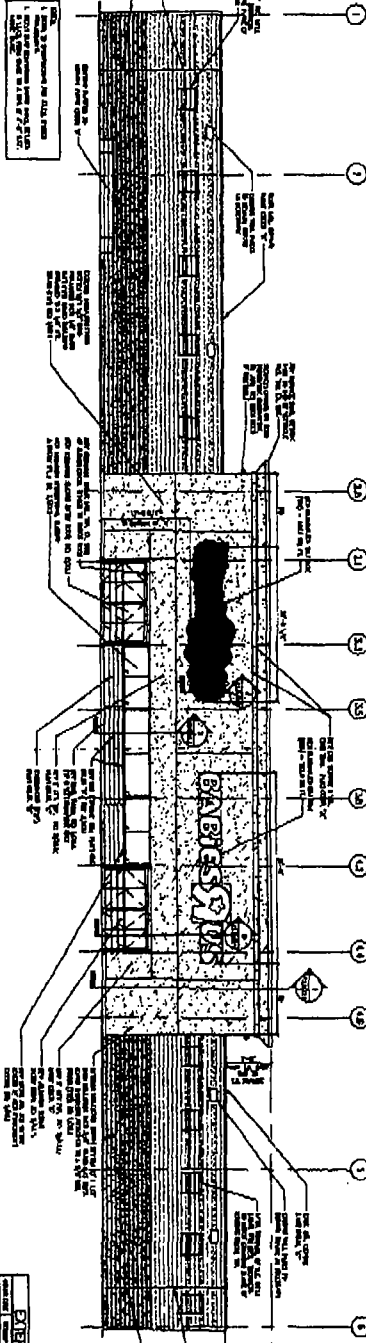

SIEN SUPPORT DETAIL

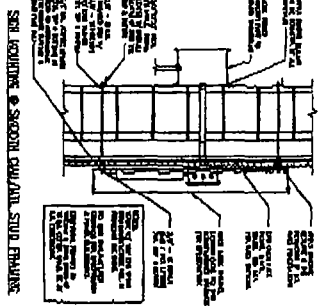

EXTERIOR FINISH SCHEDULE

Table with columns for Item, Description, and Finish. It lists various exterior finishes and their corresponding material and application notes.

Project information block containing:
- Contract: Duc & Fortneson
- Project Name: Prototype Updates
- Client: BRICKYARD, IL
- Location: 4620 S. EVERETT - SUITE A
- Architect: paep|architectural engineering, PC
- Signage: twosius®
- Scale: AS SHOWN
- Drawing: A2.00

NO SUBSTITUTIONS SHALL BE ALLOWED UNLESS OTHERWISE NOTED (REFER TO SPECIFICATIONS)

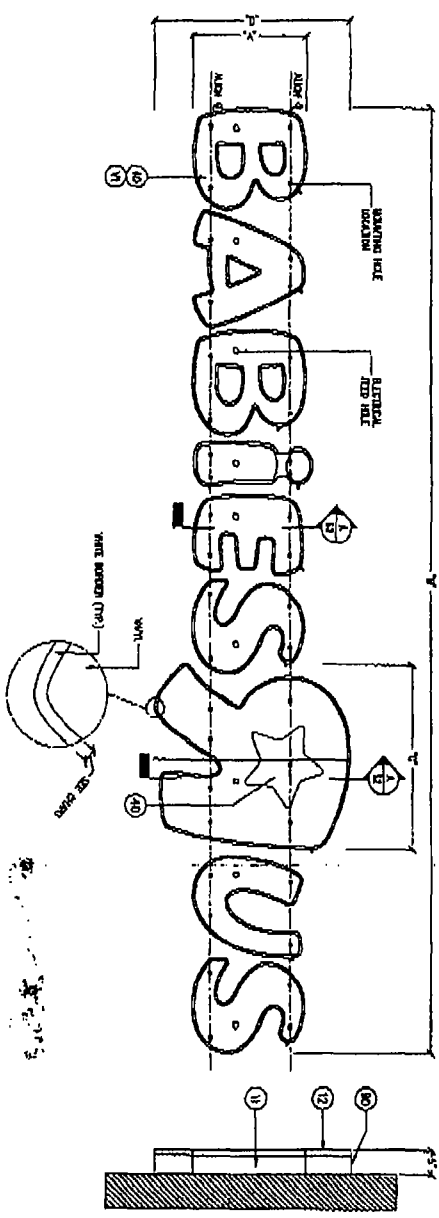

1 ELEVATIONS

SCALE 3/4\"/>

LETTER	A	B	C	D	LETTER SQ. FT.	OVERALL SQ. FT.	BACK SQ. FT.	RETURN	TRIM CAP	FACE MATERIAL
BB3	31"	14 1/2"	28 1/4"	28 1/4"	24.03	42	42"	3/8"	1"	3/8"
BB3.5	24 1/2"	15 3/4"	48 1/4"	48 1/4"	36.15	54.7	54.7"	3/8"	1"	3/8"
BB4	31"	18"	48"	48"	63.2	108.7	108.7"	3/8"	1"	3/8"
BB4.5	31"	21"	60"	60"	77.31	134.7	134.7"	3/8"	1"	3/8"
BB5	48"	24"	72"	72"	115.2	187.2	187.2"	3/8"	1"	3/8"
BB6	48"	27"	84"	84"	145.2	224.7	224.7"	3/8"	1"	3/8"
BB7	48"	30"	96"	96"	180.2	283.2	283.2"	3/8"	1"	3/8"
BB8	48"	33"	108"	108"	223.2	352.7	352.7"	3/8"	1"	3/8"
BB9	48"	36"	120"	120"	264.2	423.2	423.2"	3/8"	1"	3/8"

1 DETAIL SIZE CHART

SCALE 3/4\"/>

THIS SIGN TO BE SET IN PLACE BY THE ELECTRICAL CONTRACTOR. THE SIGN IS TO BE SET IN PLACE BY THE ELECTRICAL CONTRACTOR. THE SIGN IS TO BE SET IN PLACE BY THE ELECTRICAL CONTRACTOR.

Icon
1410 SANDSCAPE RD.
MILWAUKEE, WI 53209

1410 SANDSCAPE RD.
MILWAUKEE, WI 53209

BILL OF MATERIALS

NO.	QTY	DESCRIPTION	UNIT
1	1	ALUMINUM SIGN LETTERS (VENEER FRONT / ALUMINUM BACK)	EA
2	1	SET CHART	EA
3	1	SET CHART	EA
4	1	SET CHART	EA
5	1	SET CHART	EA
6	1	SET CHART	EA
7	1	SET CHART	EA
8	1	SET CHART	EA
9	1	SET CHART	EA
10	1	SET CHART	EA
11	1	SET CHART	EA
12	1	SET CHART	EA
13	1	SET CHART	EA
14	1	SET CHART	EA
15	1	SET CHART	EA
16	1	SET CHART	EA
17	1	SET CHART	EA
18	1	SET CHART	EA
19	1	SET CHART	EA
20	1	SET CHART	EA
21	1	SET CHART	EA
22	1	SET CHART	EA
23	1	SET CHART	EA
24	1	SET CHART	EA
25	1	SET CHART	EA
26	1	SET CHART	EA
27	1	SET CHART	EA
28	1	SET CHART	EA
29	1	SET CHART	EA
30	1	SET CHART	EA
31	1	SET CHART	EA
32	1	SET CHART	EA
33	1	SET CHART	EA
34	1	SET CHART	EA
35	1	SET CHART	EA
36	1	SET CHART	EA
37	1	SET CHART	EA
38	1	SET CHART	EA
39	1	SET CHART	EA
40	1	SET CHART	EA
41	1	SET CHART	EA
42	1	SET CHART	EA
43	1	SET CHART	EA
44	1	SET CHART	EA
45	1	SET CHART	EA
46	1	SET CHART	EA
47	1	SET CHART	EA
48	1	SET CHART	EA
49	1	SET CHART	EA
50	1	SET CHART	EA
51	1	SET CHART	EA
52	1	SET CHART	EA
53	1	SET CHART	EA
54	1	SET CHART	EA
55	1	SET CHART	EA
56	1	SET CHART	EA
57	1	SET CHART	EA
58	1	SET CHART	EA
59	1	SET CHART	EA
60	1	SET CHART	EA
61	1	SET CHART	EA
62	1	SET CHART	EA
63	1	SET CHART	EA
64	1	SET CHART	EA
65	1	SET CHART	EA
66	1	SET CHART	EA
67	1	SET CHART	EA
68	1	SET CHART	EA
69	1	SET CHART	EA
70	1	SET CHART	EA
71	1	SET CHART	EA
72	1	SET CHART	EA
73	1	SET CHART	EA
74	1	SET CHART	EA
75	1	SET CHART	EA
76	1	SET CHART	EA
77	1	SET CHART	EA
78	1	SET CHART	EA
79	1	SET CHART	EA
80	1	SET CHART	EA
81	1	SET CHART	EA
82	1	SET CHART	EA
83	1	SET CHART	EA
84	1	SET CHART	EA
85	1	SET CHART	EA
86	1	SET CHART	EA
87	1	SET CHART	EA
88	1	SET CHART	EA
89	1	SET CHART	EA
90	1	SET CHART	EA
91	1	SET CHART	EA
92	1	SET CHART	EA
93	1	SET CHART	EA
94	1	SET CHART	EA
95	1	SET CHART	EA
96	1	SET CHART	EA
97	1	SET CHART	EA
98	1	SET CHART	EA
99	1	SET CHART	EA
100	1	SET CHART	EA

ToysRUs

1410 SANDSCAPE RD.
MILWAUKEE, WI 53209

1410 SANDSCAPE RD.
MILWAUKEE, WI 53209

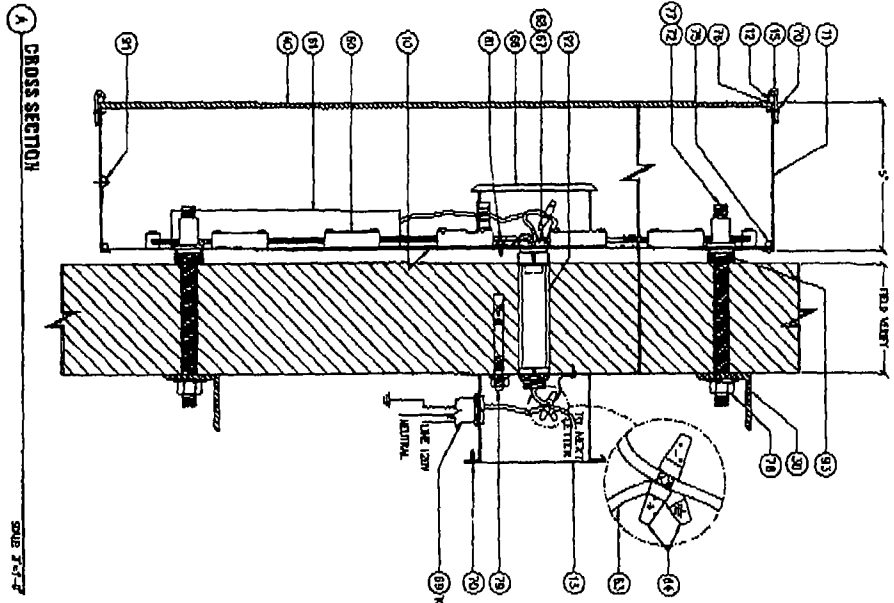

WARNING:
DO NOT REMOVE THE PLASTIC HOUSING FROM THE UNIT.
REMOVAL OF THE HOUSING WILL VOID THE WARRANTY.

NOTE:
ALL DIMENSIONS SHALL BE EXPRESSED IN DECIMAL INCHES.
DIMENSIONS IN PARENTHESES ARE FOR INFORMATION ONLY.
DIMENSIONS IN PARENTHESES ARE FOR INFORMATION ONLY.
DIMENSIONS IN PARENTHESES ARE FOR INFORMATION ONLY.

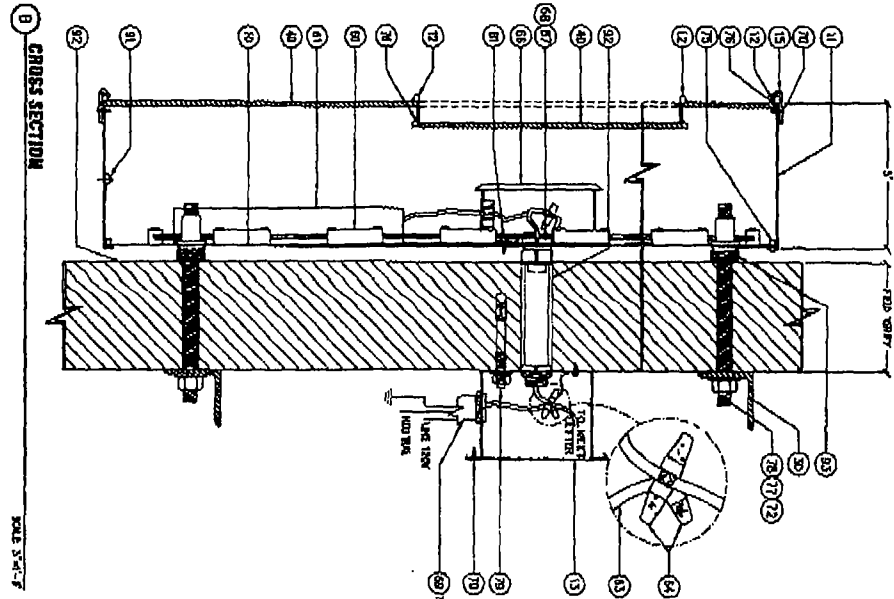

icon
1424 EXHIBITION BLVD
SUNNYVALE, CA 94086
TEL: 415-335-7000
WWW.ICON.COM

REVISIONS TO THIS DRAWING:

NO.	DESCRIPTION	DATE
1	ISSUE FOR PRODUCTION	03/25/2013

TOYS'R'US

LOCATION: -
REQUEST NO.: 67067
DRAWN BY: BLAZA BANIEL
DATE DRAWN: 03/25/2013
CHECKED BY: -
DATE CHECKED: -
FILE NUMBER: 2711

ALL DIMENSIONS ARE IN INCHES UNLESS OTHERWISE SPECIFIED. DIMENSIONS IN PARENTHESES ARE FOR INFORMATION ONLY.

Zoning Map

Created on: 10/4/2013 1:25 P.M.

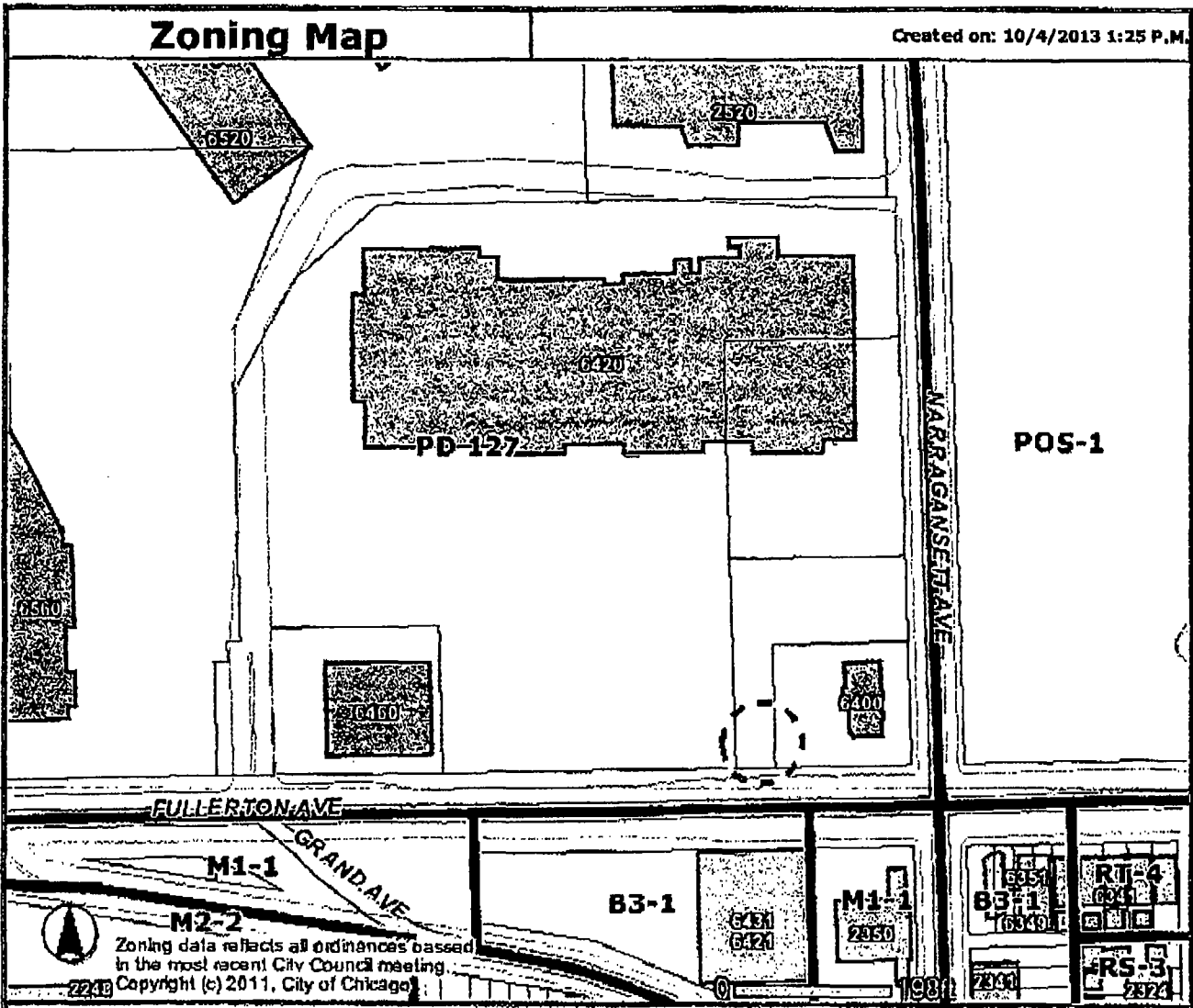

Zoning data reflects all ordinances passed in the most recent City Council meeting.
 Copyright (c) 2011, City of Chicago

Address

6420 W FULLERTON AVE

Zoning

- Business
- Commercial
- Manufacturing
- Residential
- Planned Development
- Planned Manufacturing
- Downtown Core
- Downtown Service
- Downtown Mixed
- Downtown Residential
- Transportation
- Parks & Open Space
- Zoning Boundaries

Historic Preservation

- CHICAGO LANDMARKS
- Chicago Landmarks
 - Landmark Districts
- Chicago Historic Resources Survey - Buildings subject to Demolition-Delay Ordinance
- Red
 - Orange
 - Forest Preserve
 - City Boundary

Lakefront

Pedestrian Streets

Buildings

Parcels

Streets

Water

Cemetery

Municipalities

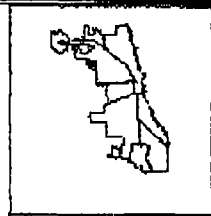

Information provided on the City of Chicago web site should not be used as a substitute for legal, accounting, real estate, business, tax, or other professional advice. The City of Chicago assumes no liability for any damages or loss of any kind that might arise from the use of, misuse of, or the inability to use the City web site and/or the materials contained on the web site. The City of Chicago also assumes no liability for improper or incorrect use of materials or information contained on its web site. All materials that appear on the City of Chicago web site are distributed and transmitted as is, without warranties of any kind, either express or implied, and subject to the terms and

CITY OF CHICAGO
DEPARTMENT OF ZONING AND LAND USE PLANNING
SIGN SITE PLAN

(ALL INFORMATION MUST BE COMPLETED AND LEGIBLE)

Site Address: 6420 W. Fullerton Ave 2 of 2 applications

Sign Company: Corporate ID Solutions Rep Name: Sean

Phone (773) 763-9600 EXT _____ (Below: Building, streets and location of sign on lot or structure)
North

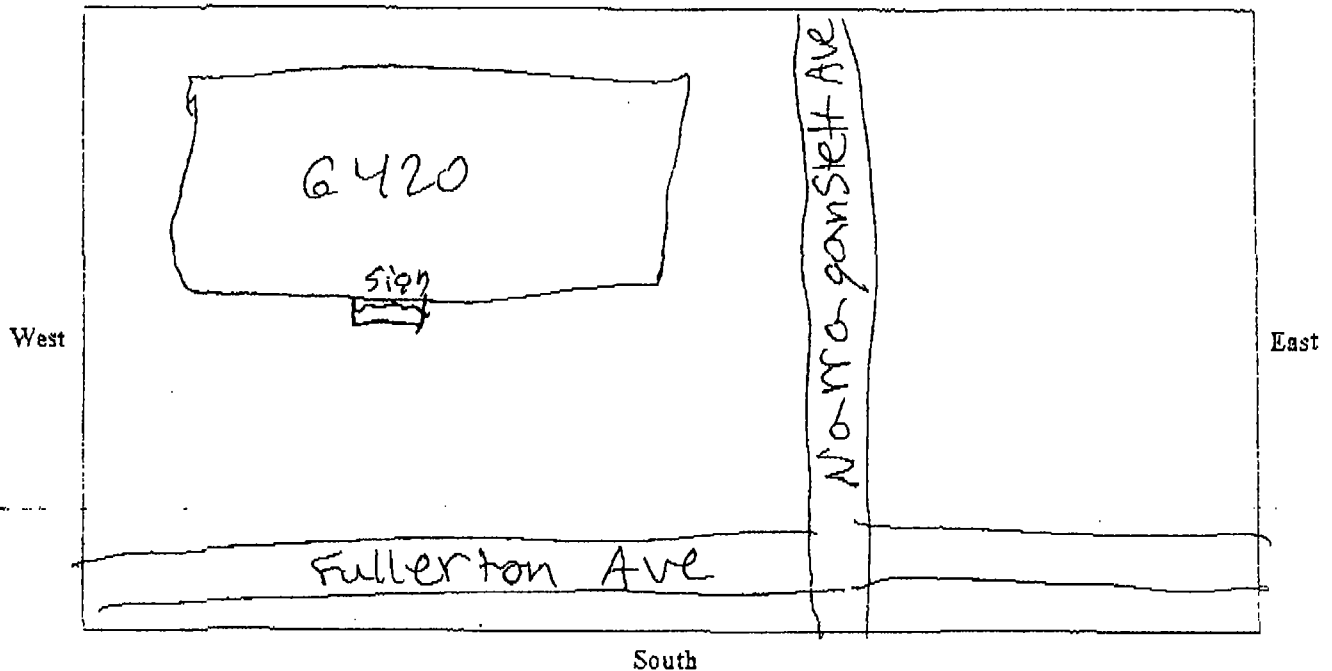

SIGN USE:

Bus. ID (On-premise)
Business Lice. # _____

Advertising (Off-premise)

PERMIT TYPE:

New Construction
Change of Face _____
Previous Permit # _____

TYPE OF SIGN:

Flat Wall
Freestanding
Awning
Marquee
High Rise Building
Projecting Private
Projecting Public Way
Public Way Use -Permit # _____

SIGN CHARACTERISTICS:

Non- Illuminated
Illuminated
Changing Image
Video Display
Flashing

DISTANCE FROM:

Curb Line: 350 ft
Expressway, Toll Roads
or Major Route
(n/a if over 1000 ft) NA
Park (over 10 acres) NA
Residential Zone 500
Existing Off-premise on
same side of street: NA

TOTAL SQUAREFOOTAGE:

Square footage of this proposed sign 168
Gross area of all proposed signs 305
Area of all existing signs
(not including proposed) on Zoning Lot 130

Signature: Sean Pitt

Date: 10/14/2013