



# City of Chicago



O2015-473

Office of the City Clerk

## Document Tracking Sheet

<b>Meeting Date:</b>	1/21/2015
<b>Sponsor(s):</b>	Waguespack (32)
<b>Type:</b>	Ordinance
<b>Title:</b>	Awning(s) for White House Black Market
<b>Committee(s) Assignment:</b>	Committee on Transportation and Public Way

ORDINANCE  
WHITE HOUSE BLACK MARKET  
Acct. No. 302541 - 5  
Permit No. 1115797

*Be It Ordained by the City Council of the City of Chicago:*

SECTION 1. Permission and authority are hereby given and granted to WHITE HOUSE BLACK MARKET, upon the terms and subject to the conditions of this ordinance to construct, install, maintain and use six (6) Awning(s) projecting over the public right-of-way adjacent to its premises known as 901 W. Weed St..

Said Awning(s) at W Weed St measure(s):

Two (2) at five point four two (5.42) feet in length, and four point five (4.5) feet in width for a total of forty-eight point seven eight (48.78) square feet.

Two (2) at twelve point six seven (12.67) feet in length, and four point five (4.5) feet in width for a total of one hundred fourteen point zero three (114.03) square feet.

One (1) at five point two five (5.25) feet in length, and four point five (4.5) feet in width for a total of twenty-three point six three (23.63) square feet.

One (1) at six point zero eight (6.08) feet in length, and four point five (4.5) feet in width for a total of twenty-seven point three six (27.36) square feet.

The location of said privilege shall be as shown on prints kept on file with the Department of Business Affairs and Consumer Protection and the Office of the City Clerk.

Said privilege shall be constructed in accordance with plans and specifications approved by the Zoning Department - Signs.

This grant of privilege in the public way shall be subject to the provisions of Section 10-28-015 and all other required provisions of the Municipal Code of Chicago.

The grantee shall pay to the City of Chicago as compensation for the privilege #1115797 herein granted the sum of one hundred seventy-five (\$175.00) per annum in advance.

A 25% penalty will be added for payments received after due date.

The permit holder agrees to hold the City of Chicago harmless for any damage, relocation or replacement costs associated with damage, relocation or removal of private property caused by the City performing work in the public way.

Authority herein given and granted for a period of five (5) years from and after Date of Passage.

Alderman   
Scott Waguespack 32nd Ward



**A REVERSE PUSH-THRU FACE-LIT LETTERS - ELEVATION**  
 Scale: 3/4" = 1' - 0"



**A REVERSE PUSH-THRU FACE-LIT LETTERS - SECTION**  
 Scale: N.T.S.

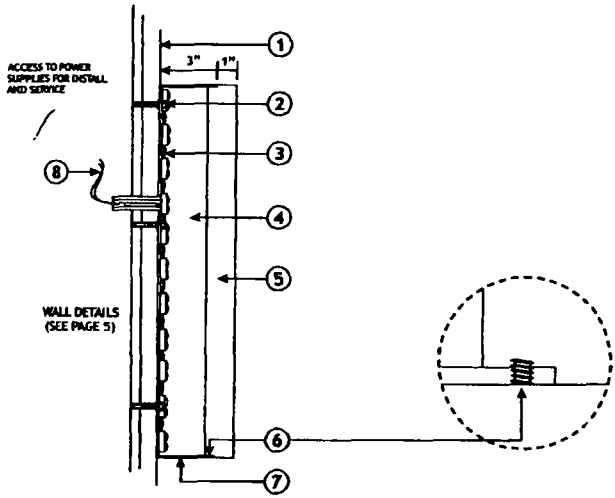

**ILLUMINATED LETTER - DETAILS**

- ① LINE OF WALL (SEE PAGE 5)
- ② FASTENERS AS REQUIRED
- ③ WHITE 6800K LED'S
- ④ ALUMINUM LETTER, INTERIOR PAINTED WHITE
- ⑤ 1 1/2" FLAME POLISHED CLEAR ACRYLIC FACE WITH TWO LAYERS OF WHITE LIGHT DIFFUSER VINYL APPLIED SECOND SURFACE
- ⑥ FACE ATTACHED WITH COUNTERSUNK SET SCREWS PAINTED BLACK S.W. GF5-95794
- ⑦ ALUMINUM LETTER RETURNS PAINTED BLACK S.W. GF5-95794, SATIN FINISH
- ⑧ CLEAR ACCESS FOR ELECTRICAL WIRING MANDATORY

WHBM11 5.5RPT

**Ruggles SIGN**  
 101 Kuhlman Blvd.  
 PO Box 349  
 Versailles, KY 40383  
 850.879.1199

**WHITE | BLACK**  
 HOUSE | MARKET

Store 3650  
 Space 4

THE SHOPS ON FREMONT  
 901 WEST WEEED STREET  
 CHICAGO, IL 60642

**CUSTOMER APPROVAL**

Customer Signature: \_\_\_\_\_ Date: \_\_\_\_\_  
 Copy, Colors and Show

**REQUIRES SIGN COMPANY DOES NOT PROVIDE PRIMARY ELECTRICAL TO SIGN LOCATION RESPONSIBILITY OF OTHERS!**

This design is the exclusive property of Ruggles Sign Company and cannot be reproduced in whole or in part without their prior written approval.

Submital Date: 08/21/14  
 Plan Issue/Rev Date: 09/17/14  
 Acct Rep: Vickie Richardson  
 Designer: Jason Elmore

**REVISIONS**

r1	08/28/14	r5	09/14/14
r2	09/09/14	r6	
r3	09/15/14	r7	
r4	09/22/14	r8	

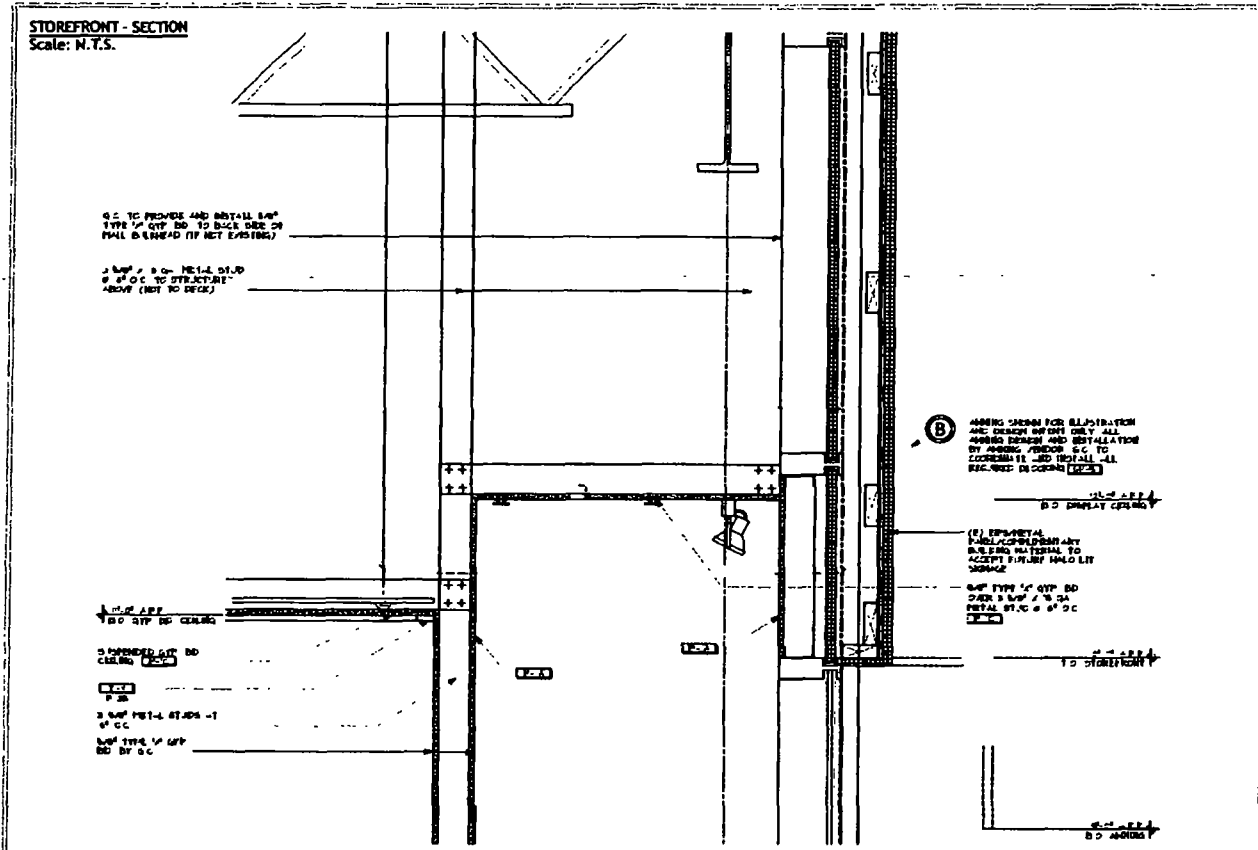



# Ruggles SIGN

101 Kuhlman Blvd.  
PO Box 349  
Versailles, KY 40383  
859.879.1199

---

**WHITE | BLACK**  
ROCK | MARKET

Store 3650  
Space 4

THE SHOPS ON FREMONT  
901 WEST WOOD STREET  
CHICAGO, IL 60642

---

**CUSTOMER APPROVAL**

Customer Signature \_\_\_\_\_ Date \_\_\_\_\_  
Copy, Colors and Size \_\_\_\_\_

**RUGGLES SIGN COMPANY DOES NOT PROVIDE  
PRIMARY ELECTRICAL TO SIGN LOCATION  
RESPONSIBILITY OF OTHERS!**

This drawing is the exclusive property of Ruggles Sign Company and cannot be reproduced in whole or in part without their prior written approval.

Submitted Date: 08/21/14  
Plan Issue/Rev Date: 09/17/14  
Acct Rep: Vicki Richardson  
Designer: Jason Elmore

---

**REVISIONS**

r1	08/28/14	r5	10/14/14
r2	09/10/14	r6	
r3	09/15/14	r7	
r4	09/22/14	r8	

- A
- WHBM11 5.SRPT  
Qty - 2
- B
- WHBM AWH S  
Qty - 6
- C
- WHBM RDP  
Qty - 1
- D
- WHBM V Doors  
Qty - 1
- E
- WHBM V com  
Qty - 4

**B STOREFRONT AWNING - END** \* See storefront elevations for V.I.F. awning sizes \* Additional site specific details by awning manufacturer  
 Scale: N.T.S.

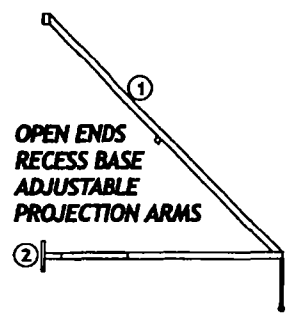
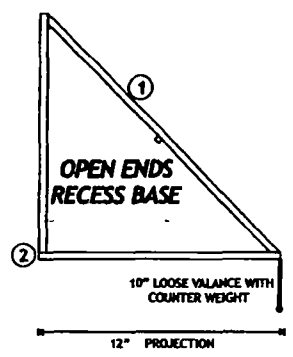
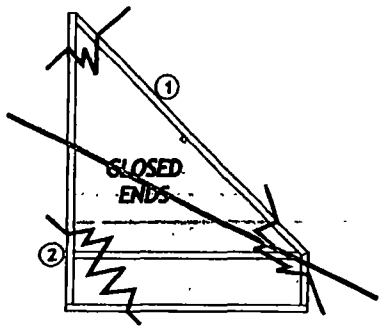

- STOREFRONT AWNING - DETAILS**
- 1 SUNBRELLA 4608 JET BLACK FABRIC ON VALANCE AND ENDS WITH WHITE INK STRIPES (B.J.L. OC65-Chemically Laced) ON DECK ONLY
  - 2 ALUM CONSTRUCTION AWNING FRAME WITH ALL CONNECTIONS WELDED. FRAME COLOR TO BE: POWDER COATED BLACK TO MATCH FABRIC
  - 3 ALL MOUNTING HARDWARE PAINTED BLACK TO MATCH FRAME. TEX SCREW/ANCHOR APPROPRIATE SIZE TO BE DETERMINED

**AWNING TYPICAL MOUNTING DETAILS**

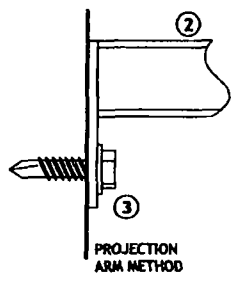
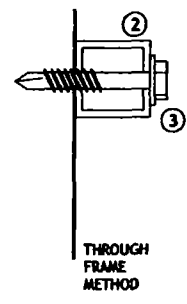
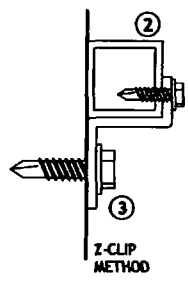

WHBM AWN S

**Ruggles SIGN**  
 101 Kuhlman Blvd.  
 PO Box 349  
 Versailles, KY 40383  
 859.879.1199

**WHITE | BLACK**  
 HOUSE | MARKET

Store 3650  
 Space 4

THE SHOPS ON FREMONT  
 901 WEST WEED STREET  
 CHICAGO, IL 60642

**CUSTOMER APPROVAL**

Customer Signature: \_\_\_\_\_ Date: \_\_\_\_\_  
 Copy, Color and Size: \_\_\_\_\_

RUGGLES SIGN COMPANY DOES NOT PROVIDE PRIMARY ELECTRICAL TO SIGN LOCATION. RESPONSIBILITY OF OTHERS!

This design is the exclusive property of Ruggles Sign Company and cannot be reproduced in whole or in part without their prior written approval.

Submittal Date: 08/21/14  
 Plan Issue/Rev Date: 09/17/14  
 Acct Rep: Nicole Richardson  
 Designer: Jason Elmore

**REVISIONS**

r1	08/28/14	r5	10/14/14
r2	09/01/14	r6	
r3	09/15/14	r7	
r4	09/22/14	r8	



**01/21/2015**

**Alderman Scott Waguespack**  
Ward # 32  
City of Chicago  
City Hall, Room 300  
121 North LaSalle Street  
Chicago, Illinois 60602

Re: An ordinance to use and maintain a portion of the public right-of-way for **six (6) awning(s)** for **WHITE HOUSE BLACK MARKET**, adjacent to the premises known as **901 W. Weed St.**.

Dear Alderman **Scott Waguespack**:

The applicant referenced above has requested the use of the public right-of-way for a **awning(s)**. An ordinance has been prepared by the Department of Business Affairs and Consumer Protection – Small Business Center - Public Way Use Unit for presentation to the City Council. Because this request was made for properties located in your ward, as approved by you as per the attached, I respectfully request that you introduce the attached ordinance at the next City Council meeting.

If you have any questions regarding this ordinance, please contact Anthony Bertuca at (312) 744-5506.

**Department of Business Affairs and Consumer Protection**