



City of Chicago



Or2016-395

Office of the City Clerk

Document Tracking Sheet

Meeting Date:	7/20/2016
Sponsor(s):	Foulkes (16)
Type:	Order
Title:	Issuance of permits for sign(s)/signboard(s) at 832 W 63rd St - south elevation
Committee(s) Assignment:	Committee on Zoning, Landmarks and Building Standards

COMMITTEE ON ZONING, LANDMARKS and BUILDING STANDARDS

(Signs)

ORDERED, That the Commissioner of Buildings is hereby directed to issue a sign permit to:

**Doyle Signs, Inc
232 W Interstate Road
Addison, IL 60101**

For the erection of a sign/signboard over 24 feet in height and/or 100 square feet (in area of one face) at:

**Whole Foods Market
832 W 63rd Street
Chicago, IL 60621**

Dimensions: Length: 17 feet - 0 inches Height: 12 feet - 5 inches

Height above grade/roof to top of sign: 26 feet - 5 inches

TOTAL SQUARE FOOT AREA: 211 square feet - South Elevation

Such sign(s) shall comply with all applicable provisions of TITLE 17 of the Chicago Zoning Ordinance and all other applicable provisions of the Municipal Code of the CITY OF CHICAGO governing the construction and maintenance of outdoor sign, signboards and structures.

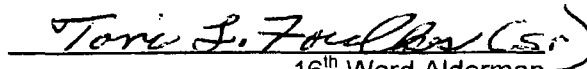
16th Ward Alderman
Toni Foulkes

7/15/16



CITY OF CHICAGO

DEPARTMENT OF BUILDINGS

Sign Permit Application

APPROVAL NUMBER	APPLICATION NUMBER 100659583	ANNUAL FEE	WORK CODE	DRAWINGS ATTACHED <input type="checkbox"/> YES <input checked="" type="checkbox"/> NO
-----------------	---------------------------------	------------	-----------	---

DATE OF APPLICATION 07/13/2016	
ADDRESS OF SIGN 832 W 63RD ST, 60621-	
BUILDING	ORIGINAL PERMIT NUMBER
TYPE OF PERMIT NEW CONSTRUCTION (SIGN)	
PAYER OF ANNUAL INSPECTION WHOLE FOODS MARKET, WHOLE FOODS MARKET 640 N LASALLE CHICAGO, IL 60654 (312)799-3600	
SIGN MANUFACTURER DOYLE SIGNS, INC	
ADDRESS WHERE SIGN CAN BE SEEN PRIOR TO ERECTION	
TICKET NUMBER 0	REINSPECTION CONTROL NUMBER UL # E31106
TYPE OF SUPPORT FOR SIGN BUILDING	
SIGN BOARD SUPPORT MEMBERS NONE	
ANNUAL FEE	
CONSTRUCTION FEE	700.00
1017 B FEE	
TOTAL FEE	700.00
AMOUNT PAID	200.00
BALANCE DUE	\$ 500.00

TYPE OF SIGN FLAT OR BOX					
LENGTH	FT 17	IN 0	HEIGHT	FT 12	IN 5
AREA	SO. FT 211	WEIGHT		LBS 300	
SIGN HEIGHT ABOVE GRADE/ROOF					FT 14
SHAPE OF SIGN REGULAR					
SIGN WILL READ WHOLE FOODS MARKET					
NO OF LAMPS 80			TOTAL WATTAGE 840		
TYPE OF LAMP OTHER					
NO OF BALLAST/TRANSFORMERS 2			INPUT OF TRANSFORMERS 120		
CONTRACTOR WILL INSTALL			<input checked="" type="checkbox"/> FEEDERS <input checked="" type="checkbox"/> CUSTOMER LEADS		
TYPE OF SWITCH SPECIAL					
LOCATION OF SWITCH OUTSIDE SIGN					
SIGN LOCATION INSTALLATION OF (1) SET OF INTERNALLY ILLUMINATED WALL MOUNTED CHANNEL LETTERS TO BE MOUNTED SOUTH BUILDING ELEVATION					

The undersigned certify that the statements in this application are true and correct; and that all work done under the proposed permit will conform to the requirements of the Chicago Municipal Code

REG. NO	E92684
ELECT CONTR DOYLE SIGNS INC	ELECTR
ADDRESS 232 INTERSTATE RD - P.O. BOX 1068 ADDISON, IL 60101-	
SUPERVISOR SIGNATURE	

BOND NO	10416 7166	REG. NO	E92684
SIGN ERECTOR DOYLE SIGNS INC	SIGNER		
ADDRESS 232 INTERSTATE RD - P.O. BOX 1068 ADDISON IL, 60101-			
SIGNATURE			

The permit issued on this application will authorize only signs here applied for. If other signs are to be erected they must be covered by additional permits

City of Chicago
Rahm Emanuel, Mayor



Department of Buildings
Judith Frydland, Commissioner

TYPE OF BUSINESS <u>COMMERCIAL</u> Other: _____ Name: <u>WHOLE FOODS MARKET</u> LIC #: _____ Renewal Date: _____	SIGN BOND REQUIRED? <input type="checkbox"/> YES COUNCIL ORDER REQUIRED <input checked="" type="checkbox"/> YES IS SPECIAL PERMISSION REQUIRED FROM CHIEF ELECTRICAL <input type="checkbox"/> YES IF YES, ATTACH LETTER OF REQUEST
Projects Over: <input checked="" type="checkbox"/> Private Property <input checked="" type="checkbox"/> Public Way Grant Permit #: _____ <input checked="" type="checkbox"/> Planned Development/Manufacturing PMD/PD# <u>1227</u> Zoning District: <u>OTHER</u> Other: <u>PD</u>	TIME STAMP
TYPE OF SIGN <input type="checkbox"/> ADVERTISING <input checked="" type="checkbox"/> ILLUMINATE <input type="checkbox"/> MOVEABLE <input checked="" type="checkbox"/> BUSINESS <input type="checkbox"/> FLASHING	
TOTAL STREET FRONTAGE OF LOT (IN FEET) _____ 500 TOTAL AREA OF NEW SIGN (SQ FT) _____ 211 TOTAL AREA OF ALL SIGNS ON LOT (SQ.FT) _____ 225 HEIGHT OF SIGN ABOVE GRADE (TO TOP) _____ 26ft 5in	
DISTANCE OF CURB LINE OUTER EDGE (ft) _____ 150 DISTANCE OF STRUCTURE INNER EDGE (ft) _____ 150	SIGN CLERK _____ APPROVED FOR PERMIT _____
DISTANCE FROM (ft): A. PUBLIC PARK (OVER 10 ACRES) _____ B. EXPRESSWAY (IF LESS THAN 1,000 FT) _____ C. RESIDENCE DISTRICT (ADVERTISING SIGNS ONLY) _____ IF REPLACEMENT SIGN OR CHANGE OF FACE, WHAT DOES THE EXISTING SIGN READ? Original Payee: _____ Landmark Hold: <input type="checkbox"/> Status: _____	REMARKS
ZONING (OFFICE USE ONLY)	

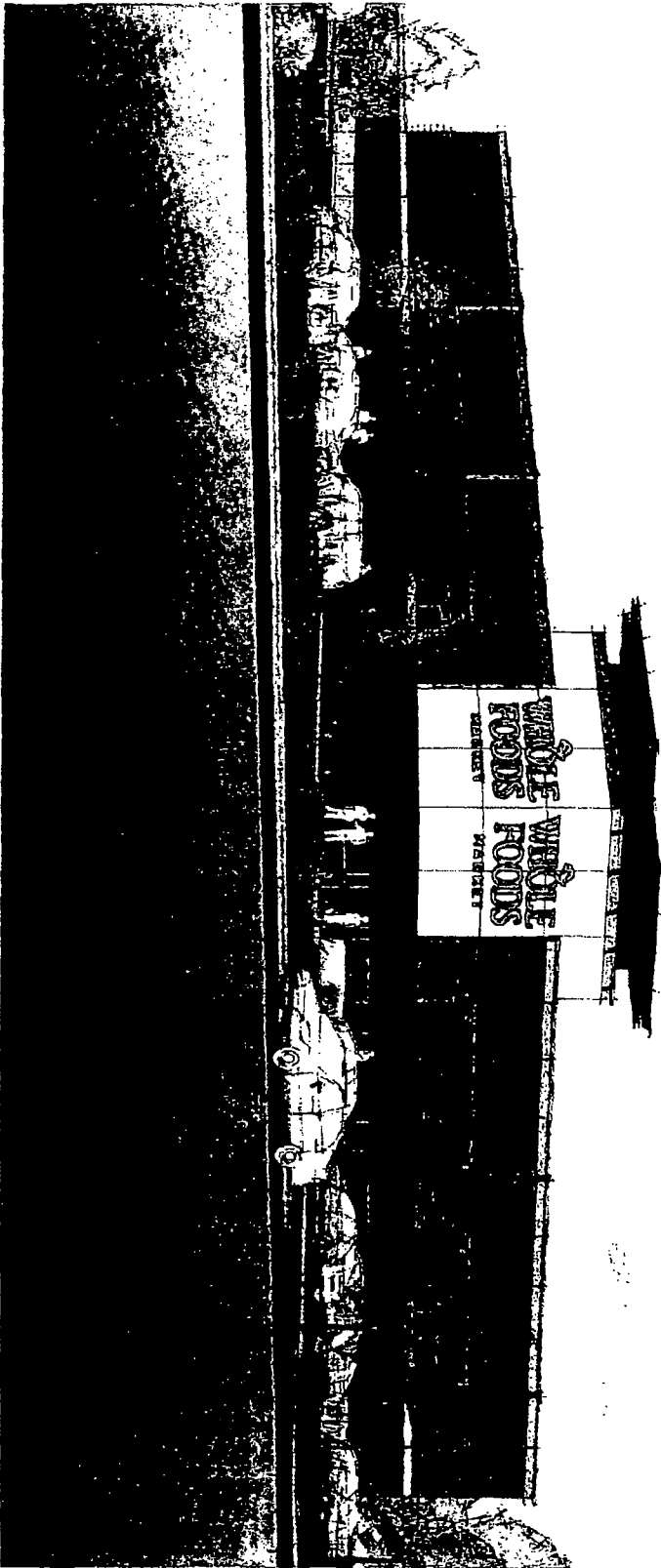

DOYLE
 GENERAL SIGN CONTRACTORS
 775 HARTWELL RD. #101 WEST LAKE
 JEFFERSON, MO 64151
 MISSOURI 64151

DATE: _____
REVISION: _____
 ALL RIGHTS RESERVED TO
 DOYLE SIGN CONTRACTORS
 775 HARTWELL RD. #101 WEST LAKE
 JEFFERSON, MO 64151

CUSTOMER APPROVAL: _____
 DATE: _____
 This design is the original and copyrighted work of
 DOYLE SIGN CONTRACTORS and may not be reproduced, copied,
 or otherwise used without the written consent of the Designer.
 The rights to this design may be purchased.

CLIENT: WHOLE FOODS - ENGLEWOOD SQUARE
ADDRESS: 832 W. 83RD ST.
CITY: CHICAGO
STATE: IL
DESIGNER: RHM
DATE: 02.08.2019
SALESPERSON: JD
PHONE, NO.: 708.457.15047
SCALE: 1/8"=1'-0"
SHEET NO.: 1
 2109P1919WHOLE FOODS/CHICAGO - ENGLEWOOD - 832 W 83RD ST/WHOLE FOODS - ENGLEWOOD.dwg

17'-0"

5'-9 1/2"

3'-6"

3'-6"

12'-4 1/4"

4'-3 1/4"

3'-6"

WHOLE FOODS

MARKET

A TWO(2) SETS OF RACEWAY MOUNTED FLEX-FACE CHANNEL LETTERS W/ L.E.D. ILLUMINATION
 SCALE: 3/8" = 1'

PMS 378 C GREEN

- LEGEND**
- 1" THIN CAP - PMS 378 C GREEN
 - 07320 WHITE - ACRYLIC FACE W/ FIRST SURFACE VINYL TO MATCH PMS 378 C
 - PAU / 083 ALUMINUM RETURN PAINTED TO MATCH PMS 378 C GREEN
 - TRANSFORMER, CLASS II 12V
 - SAFETY SWITCH
 - 050 ALUMINUM BACK
 - 120V PRIMARY NO. 12 THHN STRANDED WIRE
 - FLEXIBLE WEATHERPROOF CONDUIT PER LOCAL CODE
 - SILICONE SEAL ALL PENETRATIONS
 - UL APPROVED STANDARD BUSING
 - ALUM. FASD. RACEWAY W/ ACCESS LID
 - WHITE L.E.D. MODULE
 - 1/4" DRAIN HOLE
 - RACEWAY FINISH TO MATCH BUILDING COLOR

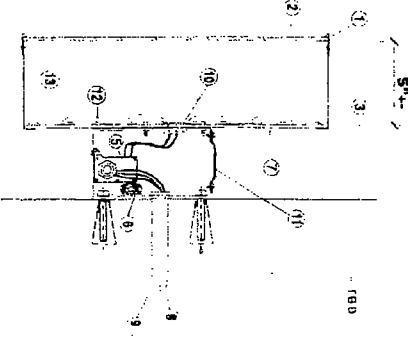

DATE _____ **REVISION** _____
 ALL CHANGES MUST BE APPROVED BY THE CLIENT AND THE DESIGNER.
 THIS DRAWING IS THE PROPERTY OF DOYLE GENERAL SIGN CONTRACTORS. IT IS TO BE USED ONLY FOR THE PROJECT AND AT THE LOCATION SPECIFIED HEREON. IT IS NOT TO BE REPRODUCED OR TRANSMITTED IN ANY FORM OR BY ANY MEANS, ELECTRONIC OR MECHANICAL, INCLUDING PHOTOCOPYING, RECORDING, OR BY ANY INFORMATION STORAGE AND RETRIEVAL SYSTEM, WITHOUT THE WRITTEN PERMISSION OF DOYLE GENERAL SIGN CONTRACTORS.

DATE _____

DISTRICT APPROVAL

This design is the original and confidential work of DOYLE GENERAL SIGN CONTRACTORS. It is the property of DOYLE GENERAL SIGN CONTRACTORS and is not to be reproduced, copied, or transmitted in any form or by any means, electronic or mechanical, including photocopying, recording, or by any information storage and retrieval system, without the written permission of DOYLE GENERAL SIGN CONTRACTORS.

CLIENT WHOLE FOODS - HANLEWOOD SQUARE
ADDRESS 632 W. 63RD ST.
CITY CHICAGO
STATE IL
DESIGNER JLN
DATE 02/08/2016
SCALE NOTED
NOTED _____
DRWG. NO. 1504
DATE 02/08/2016
DESIGNER JLN
SCALE NOTED
NOTED _____
 Z:\0416\WHOLE FOODS\CHICAGO - HANLEWOOD - 632 W 63RD ST\WHOLE FOODS - ENGLEWOOD.ctb
SHEET NO. 2

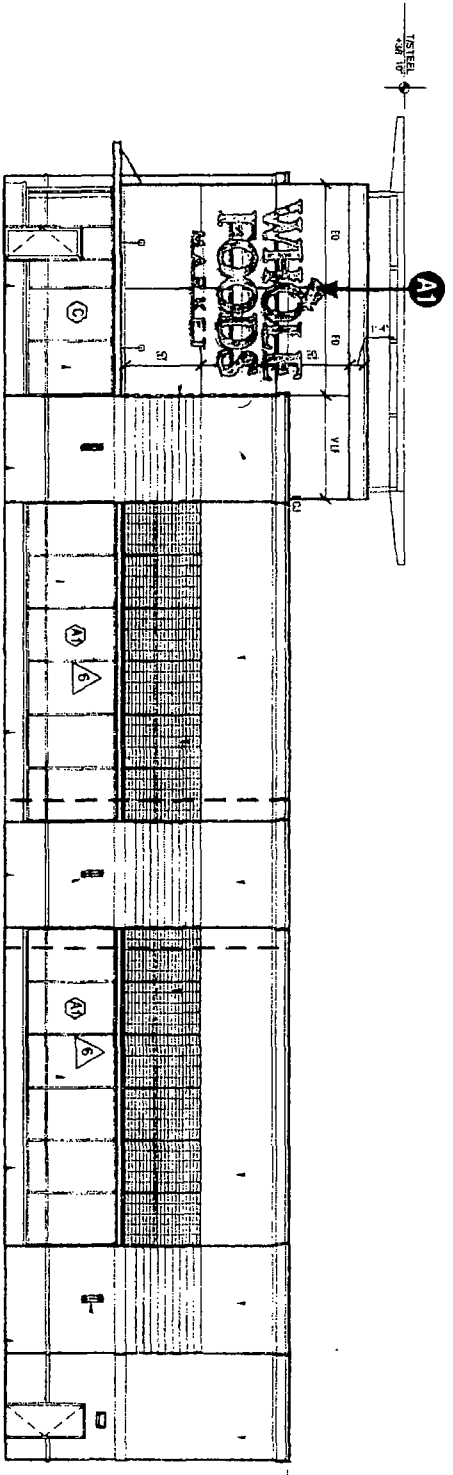

1 EAST ELEVATION
SCALE: 3/32" = 1'

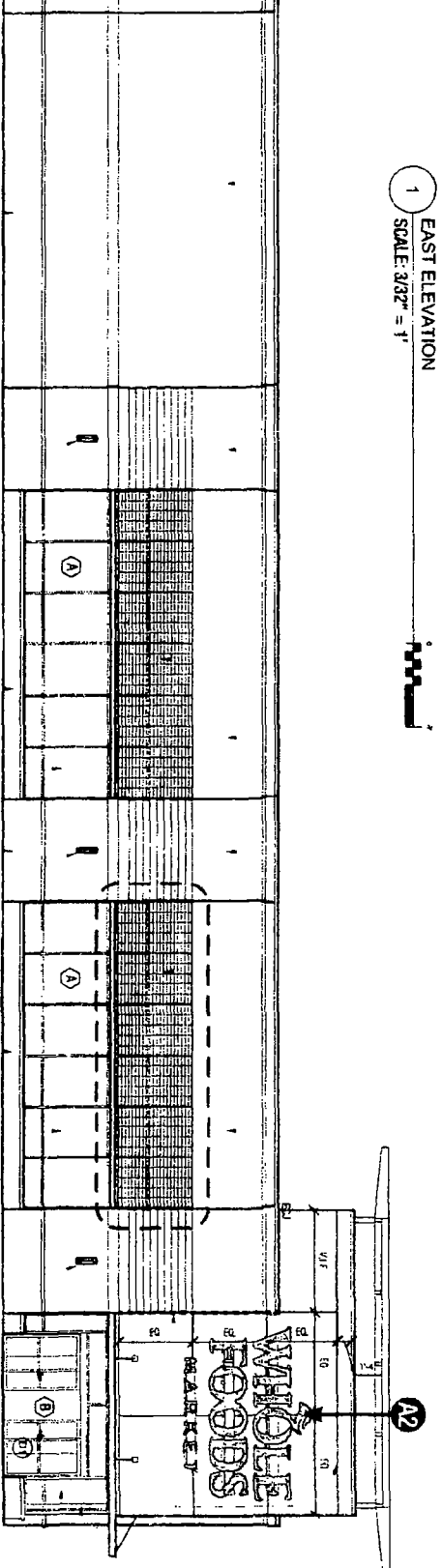

2 SOUTH ELEVATION
SCALE: 3/32" = 1'



DATE: REVISION
 1.0 11/15/16
 2.0 12/01/16
 3.0 01/11/17
 4.0 02/08/17
 5.0 03/08/17
 6.0 04/08/17
 7.0 05/08/17
 8.0 06/08/17
 9.0 07/08/17
 10.0 08/08/17
 11.0 09/08/17
 12.0 10/08/17
 13.0 11/08/17
 14.0 12/08/17
 15.0 01/09/18
 16.0 02/09/18
 17.0 03/09/18
 18.0 04/09/18
 19.0 05/09/18
 20.0 06/09/18
 21.0 07/09/18
 22.0 08/09/18
 23.0 09/09/18
 24.0 10/09/18
 25.0 11/09/18
 26.0 12/09/18
 27.0 01/10/19
 28.0 02/10/19
 29.0 03/10/19
 30.0 04/10/19
 31.0 05/10/19
 32.0 06/10/19
 33.0 07/10/19
 34.0 08/10/19
 35.0 09/10/19
 36.0 10/10/19
 37.0 11/10/19
 38.0 12/10/19
 39.0 01/11/20
 40.0 02/11/20
 41.0 03/11/20
 42.0 04/11/20
 43.0 05/11/20
 44.0 06/11/20
 45.0 07/11/20
 46.0 08/11/20
 47.0 09/11/20
 48.0 10/11/20
 49.0 11/11/20
 50.0 12/11/20
 51.0 01/12/21
 52.0 02/12/21
 53.0 03/12/21
 54.0 04/12/21
 55.0 05/12/21
 56.0 06/12/21
 57.0 07/12/21
 58.0 08/12/21
 59.0 09/12/21
 60.0 10/12/21
 61.0 11/12/21
 62.0 12/12/21
 63.0 01/13/22
 64.0 02/13/22
 65.0 03/13/22
 66.0 04/13/22
 67.0 05/13/22
 68.0 06/13/22
 69.0 07/13/22
 70.0 08/13/22
 71.0 09/13/22
 72.0 10/13/22
 73.0 11/13/22
 74.0 12/13/22
 75.0 01/14/23
 76.0 02/14/23
 77.0 03/14/23
 78.0 04/14/23
 79.0 05/14/23
 80.0 06/14/23
 81.0 07/14/23
 82.0 08/14/23
 83.0 09/14/23
 84.0 10/14/23
 85.0 11/14/23
 86.0 12/14/23
 87.0 01/15/24
 88.0 02/15/24
 89.0 03/15/24
 90.0 04/15/24
 91.0 05/15/24
 92.0 06/15/24
 93.0 07/15/24
 94.0 08/15/24
 95.0 09/15/24
 96.0 10/15/24
 97.0 11/15/24
 98.0 12/15/24
 99.0 01/16/25
 100.0 02/16/25
 101.0 03/16/25
 102.0 04/16/25
 103.0 05/16/25
 104.0 06/16/25
 105.0 07/16/25
 106.0 08/16/25
 107.0 09/16/25
 108.0 10/16/25
 109.0 11/16/25
 110.0 12/16/25
 111.0 01/17/26
 112.0 02/17/26
 113.0 03/17/26
 114.0 04/17/26
 115.0 05/17/26
 116.0 06/17/26
 117.0 07/17/26
 118.0 08/17/26
 119.0 09/17/26
 120.0 10/17/26
 121.0 11/17/26
 122.0 12/17/26
 123.0 01/18/27
 124.0 02/18/27
 125.0 03/18/27
 126.0 04/18/27
 127.0 05/18/27
 128.0 06/18/27
 129.0 07/18/27
 130.0 08/18/27
 131.0 09/18/27
 132.0 10/18/27
 133.0 11/18/27
 134.0 12/18/27
 135.0 01/19/28
 136.0 02/19/28
 137.0 03/19/28
 138.0 04/19/28
 139.0 05/19/28
 140.0 06/19/28
 141.0 07/19/28
 142.0 08/19/28
 143.0 09/19/28
 144.0 10/19/28
 145.0 11/19/28
 146.0 12/19/28
 147.0 01/20/29
 148.0 02/20/29
 149.0 03/20/29
 150.0 04/20/29
 151.0 05/20/29
 152.0 06/20/29
 153.0 07/20/29
 154.0 08/20/29
 155.0 09/20/29
 156.0 10/20/29
 157.0 11/20/29
 158.0 12/20/29
 159.0 01/21/30
 160.0 02/21/30
 161.0 03/21/30
 162.0 04/21/30
 163.0 05/21/30
 164.0 06/21/30
 165.0 07/21/30
 166.0 08/21/30
 167.0 09/21/30
 168.0 10/21/30
 169.0 11/21/30
 170.0 12/21/30
 171.0 01/22/31
 172.0 02/22/31
 173.0 03/22/31
 174.0 04/22/31
 175.0 05/22/31
 176.0 06/22/31
 177.0 07/22/31
 178.0 08/22/31
 179.0 09/22/31
 180.0 10/22/31
 181.0 11/22/31
 182.0 12/22/31
 183.0 01/23/32
 184.0 02/23/32
 185.0 03/23/32
 186.0 04/23/32
 187.0 05/23/32
 188.0 06/23/32
 189.0 07/23/32
 190.0 08/23/32
 191.0 09/23/32
 192.0 10/23/32
 193.0 11/23/32
 194.0 12/23/32
 195.0 01/24/33
 196.0 02/24/33
 197.0 03/24/33
 198.0 04/24/33
 199.0 05/24/33
 200.0 06/24/33
 201.0 07/24/33
 202.0 08/24/33
 203.0 09/24/33
 204.0 10/24/33
 205.0 11/24/33
 206.0 12/24/33
 207.0 01/25/34
 208.0 02/25/34
 209.0 03/25/34
 210.0 04/25/34
 211.0 05/25/34
 212.0 06/25/34
 213.0 07/25/34
 214.0 08/25/34
 215.0 09/25/34
 216.0 10/25/34
 217.0 11/25/34
 218.0 12/25/34
 219.0 01/26/35
 220.0 02/26/35
 221.0 03/26/35
 222.0 04/26/35
 223.0 05/26/35
 224.0 06/26/35
 225.0 07/26/35
 226.0 08/26/35
 227.0 09/26/35
 228.0 10/26/35
 229.0 11/26/35
 230.0 12/26/35
 231.0 01/27/36
 232.0 02/27/36
 233.0 03/27/36
 234.0 04/27/36
 235.0 05/27/36
 236.0 06/27/36
 237.0 07/27/36
 238.0 08/27/36
 239.0 09/27/36
 240.0 10/27/36
 241.0 11/27/36
 242.0 12/27/36
 243.0 01/28/37
 244.0 02/28/37
 245.0 03/28/37
 246.0 04/28/37
 247.0 05/28/37
 248.0 06/28/37
 249.0 07/28/37
 250.0 08/28/37
 251.0 09/28/37
 252.0 10/28/37
 253.0 11/28/37
 254.0 12/28/37
 255.0 01/29/38
 256.0 02/29/38
 257.0 03/29/38
 258.0 04/29/38
 259.0 05/29/38
 260.0 06/29/38
 261.0 07/29/38
 262.0 08/29/38
 263.0 09/29/38
 264.0 10/29/38
 265.0 11/29/38
 266.0 12/29/38
 267.0 01/30/39
 268.0 02/30/39
 269.0 03/30/39
 270.0 04/30/39
 271.0 05/30/39
 272.0 06/30/39
 273.0 07/30/39
 274.0 08/30/39
 275.0 09/30/39
 276.0 10/30/39
 277.0 11/30/39
 278.0 12/30/39
 279.0 01/31/40
 280.0 02/31/40
 281.0 03/31/40
 282.0 04/31/40
 283.0 05/31/40
 284.0 06/31/40
 285.0 07/31/40
 286.0 08/31/40
 287.0 09/31/40
 288.0 10/31/40
 289.0 11/31/40
 290.0 12/31/40
 291.0 01/32/41
 292.0 02/32/41
 293.0 03/32/41
 294.0 04/32/41
 295.0 05/32/41
 296.0 06/32/41
 297.0 07/32/41
 298.0 08/32/41
 299.0 09/32/41
 300.0 10/32/41
 301.0 11/32/41
 302.0 12/32/41
 303.0 01/33/42
 304.0 02/33/42
 305.0 03/33/42
 306.0 04/33/42
 307.0 05/33/42
 308.0 06/33/42
 309.0 07/33/42
 310.0 08/33/42
 311.0 09/33/42
 312.0 10/33/42
 313.0 11/33/42
 314.0 12/33/42
 315.0 01/34/43
 316.0 02/34/43
 317.0 03/34/43
 318.0 04/34/43
 319.0 05/34/43
 320.0 06/34/43
 321.0 07/34/43
 322.0 08/34/43
 323.0 09/34/43
 324.0 10/34/43
 325.0 11/34/43
 326.0 12/34/43
 327.0 01/35/44
 328.0 02/35/44
 329.0 03/35/44
 330.0 04/35/44
 331.0 05/35/44
 332.0 06/35/44
 333.0 07/35/44
 334.0 08/35/44
 335.0 09/35/44
 336.0 10/35/44
 337.0 11/35/44
 338.0 12/35/44
 339.0 01/36/45
 340.0 02/36/45
 341.0 03/36/45
 342.0 04/36/45
 343.0 05/36/45
 344.0 06/36/45
 345.0 07/36/45
 346.0 08/36/45
 347.0 09/36/45
 348.0 10/36/45
 349.0 11/36/45
 350.0 12/36/45
 351.0 01/37/46
 352.0 02/37/46
 353.0 03/37/46
 354.0 04/37/46
 355.0 05/37/46
 356.0 06/37/46
 357.0 07/37/46
 358.0 08/37/46
 359.0 09/37/46
 360.0 10/37/46
 361.0 11/37/46
 362.0 12/37/46
 363.0 01/38/47
 364.0 02/38/47
 365.0 03/38/47
 366.0 04/38/47
 367.0 05/38/47
 368.0 06/38/47
 369.0 07/38/47
 370.0 08/38/47
 371.0 09/38/47
 372.0 10/38/47
 373.0 11/38/47
 374.0 12/38/47
 375.0 01/39/48
 376.0 02/39/48
 377.0 03/39/48
 378.0 04/39/48
 379.0 05/39/48
 380.0 06/39/48
 381.0 07/39/48
 382.0 08/39/48
 383.0 09/39/48
 384.0 10/39/48
 385.0 11/39/48
 386.0 12/39/48
 387.0 01/40/49
 388.0 02/40/49
 389.0 03/40/49
 390.0 04/40/49
 391.0 05/40/49
 392.0 06/40/49
 393.0 07/40/49
 394.0 08/40/49
 395.0 09/40/49
 396.0 10/40/49
 397.0 11/40/49
 398.0 12/40/49
 399.0 01/41/50
 400.0 02/41/50
 401.0 03/41/50
 402.0 04/41/50
 403.0 05/41/50
 404.0 06/41/50
 405.0 07/41/50
 406.0 08/41/50
 407.0 09/41/50
 408.0 10/41/50
 409.0 11/41/50
 410.0 12/41/50
 411.0 01/42/51
 412.0 02/42/51
 413.0 03/42/51
 414.0 04/42/51
 415.0 05/42/51
 416.0 06/42/51
 417.0 07/42/51
 418.0 08/42/51
 419.0 09/42/51
 420.0 10/42/51
 421.0 11/42/51
 422.0 12/42/51
 423.0 01/43/52
 424.0 02/43/52
 425.0 03/43/52
 426.0 04/43/52
 427.0 05/43/52
 428.0 06/43/52
 429.0 07/43/52
 430.0 08/43/52
 431.0 09/43/52
 432.0 10/43/52
 433.0 11/43/52
 434.0 12/43/52
 435.0 01/44/53
 436.0 02/44/53
 437.0 03/44/53
 438.0 04/44/53
 439.0 05/44/53
 440.0 06/44/53
 441.0 07/44/53
 442.0 08/44/53
 443.0 09/44/53
 444.0 10/44/53
 445.0 11/44/53
 446.0 12/44/53
 447.0 01/45/54
 448.0 02/45/54
 449.0 03/45/54
 450.0 04/45/54
 451.0 05/45/54
 452.0 06/45/54
 453.0 07/45/54
 454.0 08/45/54
 455.0 09/45/54
 456.0 10/45/54
 457.0 11/45/54
 458.0 12/45/54
 459.0 01/46/55
 460.0 02/46/55
 461.0 03/46/55
 462.0 04/46/55
 463.0 05/46/55
 464.0 06/46/55
 465.0 07/46/55
 466.0 08/46/55
 467.0 09/46/55
 468.0 10/46/55
 469.0 11/46/55
 470.0 12/46/55
 471.0 01/47/56
 472.0 02/47/56
 473.0 03/47/56
 474.0 04/47/56
 475.0 05/47/56
 476.0 06/47/56
 477.0 07/47/56
 478.0 08/47/56
 479.0 09/47/56
 480.0 10/47/56
 481.0 11/47/56
 482.0 12/47/56
 483.0 01/48/57
 484.0 02/48/57
 485.0 03/48/57
 486.0 04/48/57
 487.0 05/48/57
 488.0 06/48/57
 489.0 07/48/57
 490.0 08/48/57
 491.0 09/48/57
 492.0 10/48/57
 493.0 11/48/57
 494.0 12/48/57
 495.0 01/49/58
 496.0 02/49/58
 497.0 03/49/58
 498.0 04/49/58
 499.0 05/49/58
 500.0 06/49/58
 501.0 07/49/58
 502.0 08/49/58
 503.0 09/49/58
 504.0 10/49/58
 505.0 11/49/58
 506.0 12/49/58
 507.0 01/50/59
 508.0 02/50/59
 509.0 03/50/59
 510.0 04/50/59
 511.0 05/50/59
 512.0 06/50/59
 513.0 07/50/59
 514.0 08/50/59
 515.0 09/50/59
 516.0 10/50/59
 517.0 11/50/59
 518.0 12/50/59
 519.0 01/51/60
 520.0 02/51/60
 521.0 03/51/60
 522.0 04/51/60
 523.0 05/51/60
 524.0 06/51/60
 525.0 07/51/60
 526.0 08/51/60
 527.0 09/51/60
 528.0 10/51/60
 529.0 11/51/60
 530.0 12/51/60
 531.0 01/52/61
 532.0 02/52/61
 533.0 03/52/61
 534.0 04/52/61
 535.0 05/52/61
 536.0 06/52/61
 537.0 07/52/61
 538.0 08/52/61
 539.0 09/52/61
 540.0 10/52/61
 541.0 11/52/61
 542.0 12/52/61
 543.0 01/53/62
 544.0 02/53/62
 545.0 03/53/62
 546.0 04/53/62
 547.0 05/53/62
 548.0 06/53/62
 549.0 07/53/62
 550.0 08/53/62
 551.0 09/53/62
 552.0 10/53/62
 553.0 11/53/62
 554.0 12/53/62
 555.0 01/54/63
 556.0 02/54/63
 557.0 03/54/63
 558.0 04/54/63
 559.0 05/54/63
 560.0 06/54/63
 561.0 07/54/63
 562.0 08/54/63
 563.0 09/54/63
 564.0 10/54/63
 565.0 11/54/63
 566.0 12/54/63
 567.0 01/55/64
 568.0 02/55/64
 569.0 03/55/64
 570.0 04/55/64
 571.0 05/55/64
 572.0 06/55/64
 573.0 07/55/64
 574.0 08/55/64
 575.0 09/55/64
 576.0 10/55/64
 577.0 11/55/64
 578.0 12/55/64
 579.0 01/56/65
 580.0 02/56/65
 581.0 03/56/65
 582.0 04/56/65
 583.0 05/56/65
 584.0 06/56/65
 585.0 07/56/65
 586.0 08/56/65
 587.0 09/56/65
 588.0 10/56/65
 589.0 11/56/65
 590.0 12/56/65
 591.0 01/57/66
 592.0 02/57/66
 593.0 03/57/66
 594.0 04/57/66
 595.0 05/57/66
 596.0 06/57/66
 597.0 07/57/66
 598.0 08/57/66
 599.0 09/57/66
 600.0 10/57/66
 601.0 11/57/66
 602.0 12/57/66
 603.0 01/58/67
 604.0 02/58/67
 605.0 03/58/67
 606.0 04/58/67
 607.0 05/58/67
 608.0 06/58/67
 609.0 07/58/67
 610.0 08/58/67
 611.0 09/58/67
 612.0 10/58/67
 613.0 11/58/67
 614.0 12/58/67
 615.0 01/59/68
 616.0 02/59/68
 617.0 03/59/68
 618.0 04/59/68
 619.0 05/59/68
 620.0 06/59/68
 621.0 07/59/68
 622.0 08/59/68
 623.0 09/59/68
 624.0 10/59/68
 625.0 11/59/68
 626.0 12/59/68
 627.0 01/60/69
 628.0 02/60/69
 629.0 03/60/69
 630.0 04/60/69
 631.0 05/60/69
 632.0 06/60/69
 633.0 07/60/



DATE: 07/11/18
REVISION: REVISED SIGN DIMENSIONS TO MATCH SIGN & A DELIVERED TO THE CLIENT

CUSTOMER APPROVAL:
The client is the owner and has authorized the use of this design. The client has agreed to the terms and conditions of the contract. The client has agreed to the terms and conditions of the contract. The client has agreed to the terms and conditions of the contract.

CLIENT: WHOLE FOODS - ENGLEWOOD SQUARE
ADDRESS: 832 W 83RD ST
CITY: CHICAGO
STATE: IL
DESIGNER: KM
SCALE: NOTED
DATE: 07/09/2018
SHEET: 4
DATE: 07/09/2018
DESIGNER: KM
SCALE: NOTED
DATE: 07/09/2018
SHEET: 4

