



City of Chicago



Or2016-471

Office of the City Clerk

Document Tracking Sheet

Meeting Date:	9/14/2016
Sponsor(s):	Moreno (1)
Type:	Order
Title:	Issuance of permits for sign(s)/signboard(s) at 2251 N Milwaukee Ave
Committee(s) Assignment:	Committee on Zoning, Landmarks and Building Standards

Committee on Buildings

(signs)

ORDERED, That the Commissioner of Buildings is hereby directed to issue a sign permit
to:

Integrity Signs
18621 S 81st Ave.
Tinley Park, IL 60487

for the erection of a sign/signboard over 100' total square feet for

Orange Theory Fitness
2251 N Milwaukee Ave
Chicago, IL 60647

(1) channel letter sign

Dimensions: Length 23' 1" Height 6' 5"
Height above grade/roof to bottom of sign 14'-0"
TOTAL SQUARE FOOT AREA 148

Such sign shall comply with all applicable provisions of Chapter 194A of the Chicago Zoning Ordinance and all other applicable provisions of the Municipal Code of the City of Chicago governing the construction and maintenance of outdoor signs, signboards and structures.

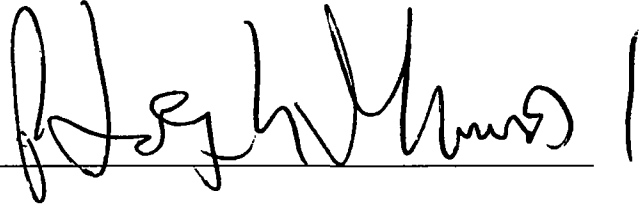

Alderman

Ward



CITY OF CHICAGO

DEPARTMENT OF BUILDINGS

Sign Permit Application

APPROVAL NUMBER	APPLICATION NUMBER 100647506	ANNUAL FEE	WORK CODE	DRAWINGS ATTACHED <input type="checkbox"/> YES <input type="checkbox"/> NO
-----------------	---------------------------------	------------	-----------	--

DATE OF APPLICATION 04/29/2016	
ADDRESS OF SIGN 2251 N MILWAUKEE AVE. 60647-	
BUILDING	ORIGINAL PERMIT NUMBER
TYPE OF PERMIT NEW CONSTRUCTION (SIGN)	
PAYER OF ANNUAL INSPECTION LANZ, DAVID 2251 N MILWAUKEE AVE CHICAGO, IL 60647 (847)274-6450	
SIGN MANUFACTURER INTEGRITY SIGN COMPANY	
ADDRESS WHERE SIGN CAN BE SEEN PRIOR TO ERECTION	
TICKET NUMBER 0	REINSPECTION CONTROL NUMBER
TYPE OF SUPPORT FOR SIGN BUILDING	
SIGN BOARD SUPPORT MEMBERS STEEL	
ANNUAL FEE	_____
CONSTRUCTION FEE	400.00
1017 B FEE	_____
TOTAL FEE	400.00
AMOUNT PAID	200.00
BALANCE DUE	\$ 200.00

TYPE OF SIGN FLAT OR BOX					
LENGTH	FT 23	IN 2	HEIGHT	FT 6	IN 5
AREA	SQ FT 149	WEIGHT		LBS 500	
SIGN HEIGHT ABOVE GRADE ROOF					FT 14
SHAPE OF SIGN IRREGULAR					
SIGN WILL READ PHYSICS THEORY FITNESS					
NO. OF LAMPS 500			TOTAL WATTAGE 500		
TYPE OF LAMP OTHER					
NO. OF BALLAST/TRANSFORMERS 4			INPUT OF TRANSFORMERS 120		
CONTRACTOR WILL INSTALL			<input checked="" type="checkbox"/> FEEDERS <input checked="" type="checkbox"/> CUSTOMER LEADS		
TYPE OF SWITCH KNIFE					
LOCATION OF SWITCH OUTSIDE SIGN					
SIGN LOCATION INSTALL (1) SET INTERNALLY ILLUMINATED CHANNEL LETTERS ABOVE STOREFRONT ON SW ELEVATION AND CONNECT TO SUPPLIED LEADS.					

The undersigned certify that the statements in this application are true and correct and that all work done under the proposed permit will conform to the requirements of the Chicago Municipal Code.

REG. NO	E93455
ELECTR CONTR 3 S SUPPLY COMPANY	ELECTR
ADDRESS 14650 TEAL DRIVE HOMER GLEN, IL 60491	
SUPERVISOR SIGNATURE 	

BOND NO	REG NO	N93888
SIGN ERECTOR INTEGRITY SIGN CO	SIGNER	
ADDRESS 18621 S 81ST AVE TINLEY PARK IL, 60487-		
SIGNATURE 		

The permit issued on this application will authorize only signs here applied for. If other signs are to be erected they must be covered by additional permits.

City of Chicago
Rahm Emanuel, Mayor



Department of Buildings
Judith Frydland, Commissioner

Council order

TYPE OF BUSINESS <u>COMMERCIAL</u> Other: <u>FITNESS</u> Name: <u>ORANGE THEORY</u> LIC #: <u>2432115</u> <u>MAK 13 2016</u> Renewal Date: <u>[Signature]</u>	SIGN BOND REQUIRED? <input type="checkbox"/> YES COUNCIL ORDER REQUIRED <input checked="" type="checkbox"/> YES IS SPECIAL PERMISSION REQUIRED FROM CHIEF ELECTRICAL <input type="checkbox"/> YES IF YES, ATTACH LETTER OF REQUEST TIME STAMP
Projects Over: <input checked="" type="checkbox"/> Private Property <input checked="" type="checkbox"/> Public Way Grant Permit #: _____ <input type="checkbox"/> Planned Development/Manufacturing PMD/PD#: _____ Zoning District: <u>CI</u> Other: _____	TYPE OF SIGN: <input type="checkbox"/> ADVERTISING <input checked="" type="checkbox"/> ILLUMINATE <input type="checkbox"/> MOVEABLE <input checked="" type="checkbox"/> BUSINESS <input type="checkbox"/> FLASHING
TOTAL STREET FRONTAGE OF LOT (IN FEET) _____ 116 TOTAL AREA OF NEW SIGN (SQ.FT) _____ 149 TOTAL AREA OF ALL SIGNS ON LOT (SQ.FT.) _____ 224 HEIGHT OF SIGN ABOVE GRADE (TO TOP) _____ 20ft 5in	SIGN CLERK _____ APPROVED FOR PERMIT _____
DISTANCE OF CURB LINE OUTER EDGE (ft) _____ 100 DISTANCE OF STRUCTURE INNER EDGE (ft) _____ 101 DISTANCE FROM (ft): A. PUBLIC PARK (OVER 10 ACRES) _____ 1,200 B. EXPRESSWAY (IF LESS THAN 1,000 FT) _____ C. RESIDENCE DISTRICT (ADVERTISING SIGNS ONLY) _____ 300	REMARKS <div style="text-align: center; border: 2px solid black; padding: 10px; transform: rotate(-15deg); width: fit-content; margin: 20px auto;"> APPROVED MAY 12 2016 PUBLICWAY USE </div>
IF REPLACEMENT SIGN OR CHANGE OF FACE, WHAT DOES THE EXISTING SIGN READ? Original Payee: _____ Landmark Hold: <input type="checkbox"/> Status: _____	ZONING (OFFICE USE ONLY) <div style="text-align: center;"> <p>CONFORMS</p> <p><small>TO ZONING ORDINANCES</small></p> <p><small>This Approval of Application for signs shall not be held to permit of or approval of any violation of the provisions.</small></p> <p>JUN 1 2016</p> <p><small>of the Chicago Zoning Ordinance, or any other requirements of the Municipal Code of the City of Chicago</small></p> <p>ZONING ADMINISTRATOR</p> </div> <div style="text-align: right; margin-top: 20px;"> </div>

SUPPLEMENTAL APPLICANT

This Supplemental Application must be completed and submitted along with the Sign Permit Application. All fields must be completed. If a field is not applicable you must answer "n/a" in the field.



CITY OF CHICAGO
SIGN PERMIT APPLICATION
(THIS IS NOT A PERMIT)

Application Number: 100647506 Date of Application: 4-29-16

Address of property where sign will be erected: 2251 N MILWAUKEE AVE

Does property have multiple addresses? Yes No

If yes, please list all addresses: _____

Is this building vacant? Yes No

If yes, is it registered under the Vacant Building Ordinance? Registration # _____

Section 1 - Applicant

Applicant is the Owner (of the real property) Lessee (of the real property)

Name of Owner of Real Property: NEXT REALTY

Address: 400 SKOKIE BLVD #800, NORTHBROOK, IL 60077

Phone #: 847-274-6450 Mobile #: _____ Email: davidlanz70@gmail.com

Name of Lessee of Real Property: CHICAGOLAND FITNESS V (dba ORANGE THEORY FITNESS)

Name: DAVID LANZ Address: 1111 ASHLAND AVE, WILMETTE IL 60062

Phone #: 847-274-6450 Mobile #: _____ Email: davidlanz70@gmail.com

Section 2 - Contractors

Payer Company of Annual Inspection Fee:

Name of Contact of Payer Company: DAVID LANZ

Name of Payer Company: ORANGE THEORY FITNESS Address: 1111 ASHLAND AVE, WILMETTE, IL 60091

Phone #: 847-274-6450 Mobile #: _____ Email: davidlanz70@gmail.com

Electrical Contractor: 3 S SUPPLY COMPANY

Address: 14650 TEAL DR, HOMER GLEN, IL License #: E93455

Phone #: _____ Mobile #: _____ Email: _____

Website: _____

Sign Erector: Integrity Sign Company

Bond #: 14-809098 Registration #: N93888

Address: 18621 S. 81st Ave., Tinley Park, IL 60487

Phone #: 708-532-5038 Mobile #: 708-417-4981 Email: leny.isc@gmail.com

Website: _____

Picture or rendering must be attached depicting sign placement with before and after view. Section 2 continues on next page

CITY OF CHICAGO SIGN PERMIT APPLICATION CONTINUED

Expediter: N/A

Address: _____ License #: _____

Phone #: _____ Mobile #: _____ Email: _____

Website: _____

Section 3 - Sign and Structure Details

(Please check all that apply)

Sign Category:

On-Premise (Business ID): Dynamic Static

Business License # of Tenant Business: _____

Off-Premise (Advertising): Dynamic Static

Temporary: Special Event:

Sign will read (Please provide a description, picture and shop drawing): ORANGE THEORY FITNESS

Type of sign (Mark all that apply):

Awning Canopy Freestanding Marquee Projecting Dynamic Image Display

Wall Painted Cabinet/Frame Vinyl Projected image Flashing

High Rise Building Hotel/Hospitals Other buildings: _____

What is the dimension of the wall on which the sign will be installed? 15'H X 30'W

Where is sign or sign structure mounted? Inside the building Outside the building

Is the sign or sign structure attached to a building or wall? Yes No If yes, which wall of building? N E S W

Is this a freestanding sign? Yes No Location of sign on lot: N E S W

In which direction does sign copy face? N E S W

Does any portion of the sign, sign structure or attachments cover, obscure or obstruct an existing window in a residential unit whether occupied or not? Yes No

Does any portion of the sign, sign structure, or attachments extend on or over the public way? Yes No

If yes, what is the public way use permit number? _____

Sign Panels: Back to back within 30 degrees of parallel Yes No

Number of Faces: 1

Sign Support Structure: Pole Roof Ground Building Windows Other: _____

Does any portion of the sign or sign structure extend 24 inches above the roof line as defined in 17-17-02149 of the Municipal Code of Chicago? Yes No

Picture or rendering must be attached depicting sign placement with before and after view.

Section 3 continues on next page

CITY OF CHICAGO SIGN PERMIT APPLICATION CONTINUED

Section 3 continued

Dimensions of Sign Structure (i.e. cabinet, frame, awning, canopy)

Length: 23 Feet 2 Inches Height: 6 Feet 5 Inches Depth: 1 Feet _____ Inches

Area: 148 Sq Ft. Weight: 500 lbs.

Shape of Sign: irregular

Sign Height above Grade:

From Grade to Bottom of sign or sign structure, whichever is lowest: 14' Ft.

From Grade to Top of sign or sign structure, whichever is highest: 20'5" Ft.

Is City Council Order required? Yes No

*All signs in excess of 100 Square Feet in area OR in excess of 24 feet above grade require a City Council Order pursuant to Section 13-20-680 of the Municipal Code of Chicago

Dimension of Sign Elements pursuant to Section 17-12-0601 of the Chicago Zoning Ordinance:

Length: _____ Feet _____ Inches Height: _____ Feet _____ inches Area: _____ Sq Ft.

Electrical Contractor will install: Feeders: Yes No Customer Leads Yes No

Number of Lamps: 500 Total Wattage: 500 Type of Lamp: LED

Number of Ballast/Transformers: 4 Input of Transformers: 120

Type of Switch: KNIFE Location of Switch: OUTSIDE

Automatic: Yes No

Illuminated: Yes No

If yes - External _____ Internal

Dynamic Image Display: Yes No

An affidavit of compliance is required for all dynamic image display signs pursuant to Section 13-20-675(d)(2) of the Municipal Code of Chicago.)

Max Nits _____ Max Foot Candles _____ Message Time (Screen Hold): _____ seconds

Self Dimming Capability: Yes No

What is the total of the sign face area devoted to dynamic image display? _____ Sq Ft.

Section 4 - Zoning Information

Zoning District or Planned Development #: C1-1

Sign located in a special sign district? Yes No

If yes: Michigan Avenue Corridor Oak Street Corridor State Street/Wabash Avenue Corridor

Total Street frontage of Zoning Lot: 116 (Ft.)

Total Area of new sign: 148 (Sq Ft.) Gross Area of all proposed signs: 224 (Sq Ft.)

Total Area of all existing signs on Zoning Lot: 0 (Sq Ft.)

Picture or rendering must be attached depicting sign placement with before and after view.

Section 4 continues on next page

CITY OF CHICAGO SIGN PERMIT APPLICATION CONTINUED

Section 4 continued

Distance from outer edge of sign or structure to curb line: 100 (Ft.)

Distance from inner edge of sign or sign structure to curb line: 101 (Ft.)

Distance from:

Public Park 10 acres or more: 2500 (Ft.)

Public Park 2 acres or more: 1200 (Ft.)

Expressway or Toll Road: 4000 (Ft.)

Lake Shore Drive: 15000 (Ft.)

Michigan Avenue (Oak St. to Roosevelt Rd.): 10000 (Ft.)

Residential District: 300 (Ft.)

Residential building in a D district: 12500 (Ft.)

Existing off-premise/advertising signs on same side of street? Yes No

In a B or C District: _____ (Ft.)

In a D or M District: _____ (Ft.)

Waterways: 5000 (Ft.)

Section 5 - Sign Permit History

Does the proposed sign, change, alter or replace an existing sign? Yes No

If yes, were permits issued for the sign being replaced, changed or altered? Yes No

If yes, please list each permit number and date each permit was issued:

Permit Number: _____ Date issued: _____

Permit Number: _____ Date issued: _____

Permit Number: _____ Date issued: _____

Permit Number: _____ Date issued: _____

Does the proposed sign change a static sign to a dynamic image display sign? Yes No

Does the proposed sign change or alter the square footage or the height of the sign or sign structure? Yes No

Does the proposed sign change an on-premise sign to an off-premise/advertising sign? Yes No

Section 6 - Attestation and Signatures

We, the undersigned, under penalty of perjury, do hereby affirm and attest that the above information is true, complete, and correct and acknowledge that incorrect information is grounds to revoke or rescind a permit.

Owner of Real Property: Richard Beage Date 1/4/16

Lessee of Real Property: [Signature] Date 1/4/2016

Expediter: _____ Date _____

Supervising Electrician: [Signature] Date 5-2-16

Sign Erector: [Signature] Date 5/2/16

Picture or rendering must be attached depicting sign placement with before and after view.

For Office Use

ZONING	PUBLIC WAY

Sign Review Fee:

Zoning Review Fee: \$ _____ Total Fee: \$ _____

Amount Paid: \$ _____ Balance Due: \$ _____

PERMIT IS VALID FOR A PERIOD OF FIVE YEARS AFTER ISSUANCE. IT IS SOLELY THE RESPONSIBILITY OF THE OWNER OR LESSEE TO FILE FOR RENEWAL

* Once zoning fee is paid, this application is valid for a period of up to six months from payment date.

Applies to sign permits applied for on or after April 2, 2014.

City of Chicago
Mayor Rahm Emanuel



Department of Buildings
Felicia Davis, Commissioner

RACEWAY MOUNTED CHANNEL LETTERS

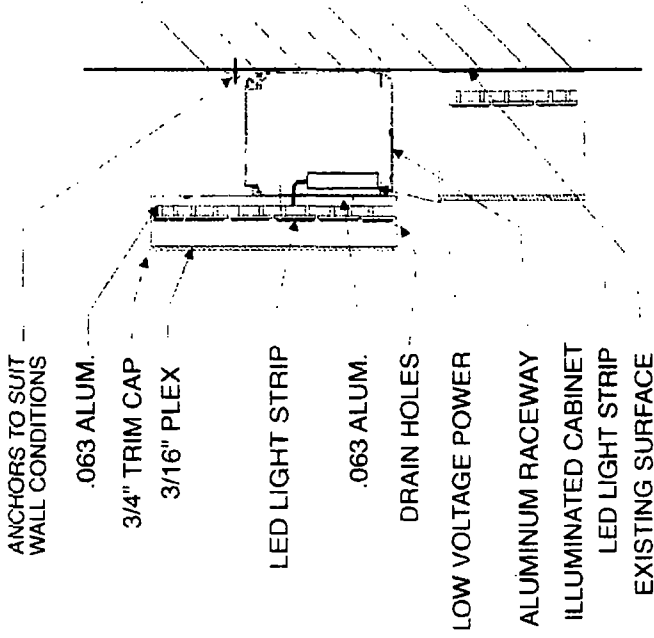
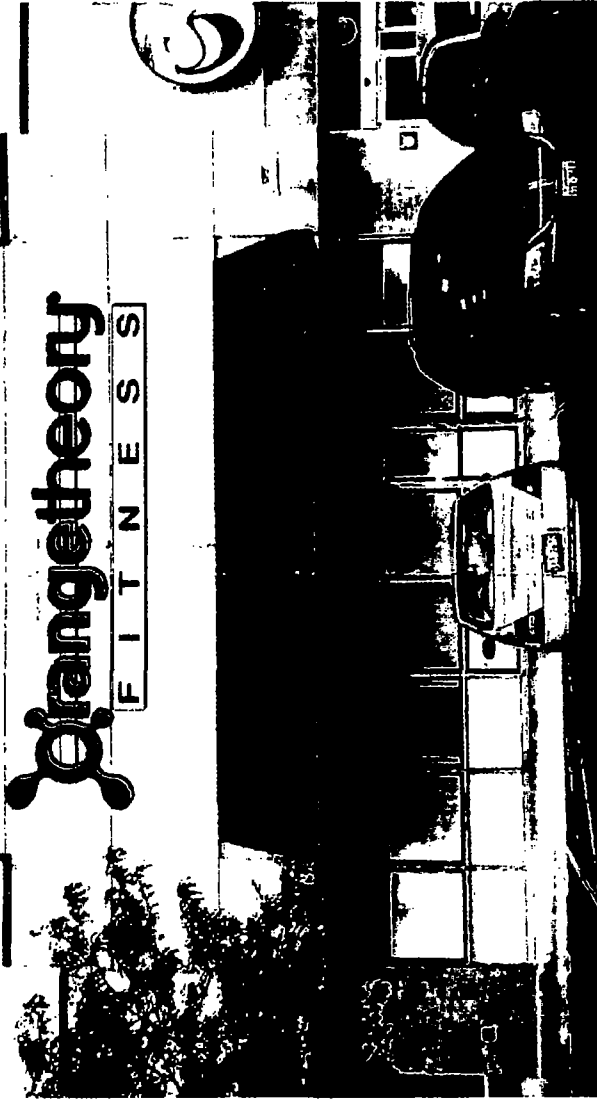

- 3M 3630-084 TANGERINE
- ORACAL 8500-031 RED
- ORACAL 8500-074 MIDDLE GREY
- BLACK TRIM AND RETURN

Orangetheory[®]

F I T N E S S

77 in
89.4 in

22.5 in
30.8 in

17.2 in

277.6 in.

These drawings are the exclusive property of Integrity Sign Company. Any use, other than that intended is not allowed without the express written authorization of Integrity Sign Company. Ideas contained herein are considered intellectual property and are protected under law. © Integrity Sign Company. The prices, specifications and conditions as described are satisfactory and hereby accepted. Integrity Sign Company is authorized to do the work as specified.

Directory Name: \\Rippend\ORANGE THEORY

Customer: Address:

Current Date: 11/3/2015

File Name: Orange Theory - Logan Square.fs

Drawn By: JS

Salesperson

Approved By:

Date:



18621 S. 81st Ave.
Tinley Park, IL 60487
708-532-5038
708-532-5058

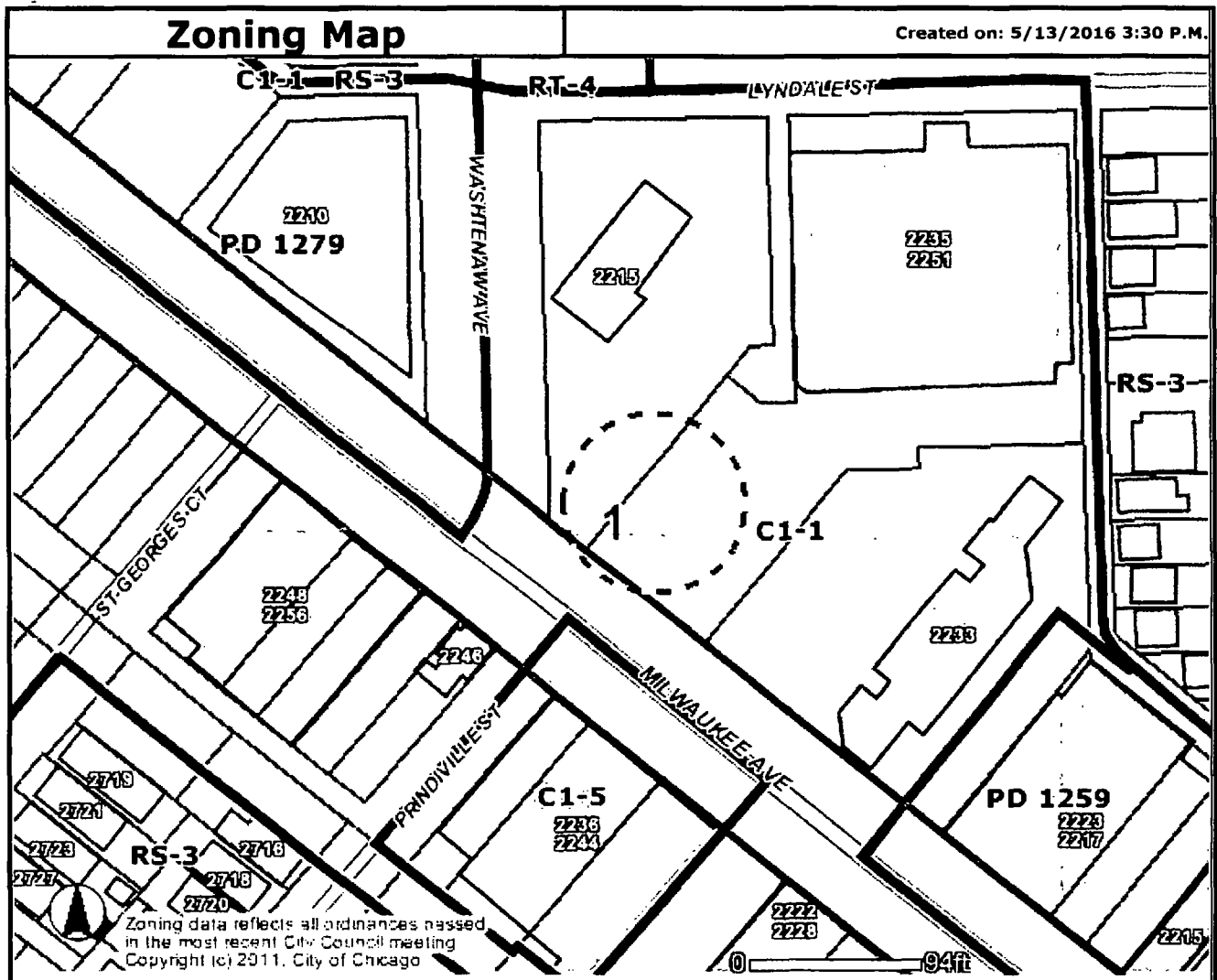

Address

2251 N MILWAUKEE AVE

- | | | |
|---|--|--|
| Zoning | Historic Preservation | Lakefront |
| <input type="checkbox"/> Business | CHICAGO LANDMARKS | <input type="checkbox"/> Pedestrian Streets |
| <input type="checkbox"/> Commercial | <input checked="" type="checkbox"/> Chicago Landmarks | <input type="checkbox"/> Special Districts |
| <input type="checkbox"/> Manufacturing | <input checked="" type="checkbox"/> Landmark Districts | <input type="checkbox"/> Central Business Dist |
| <input type="checkbox"/> Residential | Chicago Historic Resources Survey - Buildings subject to Demolition-Delay Ordinance | <input type="checkbox"/> Buildings |
| <input type="checkbox"/> Planned Development | <input type="checkbox"/> Red | <input type="checkbox"/> Parcels |
| <input type="checkbox"/> Planned Manufacturing | <input type="checkbox"/> Orange | <input type="checkbox"/> Streets |
| <input type="checkbox"/> Downtown Core | <input type="checkbox"/> Wards | <input type="checkbox"/> Water |
| <input type="checkbox"/> Downtown Service | Curbs | <input type="checkbox"/> Cemetery |
| <input type="checkbox"/> Downtown Mixed | <input type="checkbox"/> Forest Preserve | <input type="checkbox"/> Municipalities |
| <input type="checkbox"/> Downtown Residential | <input type="checkbox"/> City Boundary | |
| <input checked="" type="checkbox"/> Transportation | | |
| <input type="checkbox"/> Parks & Open Space | | |
| <input checked="" type="checkbox"/> Zoning Boundaries | | |

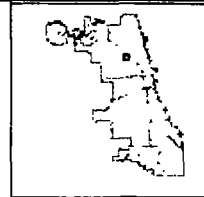

Information provided on the City of Chicago web site should not be used as a substitute for legal, accounting, real estate, business, tax, or other professional advice. The City of Chicago assumes no liability for any damages or loss of any kind that might arise from the use of, misuse of, or the inability to use the City web site and/or the materials contained on the web site. The City of Chicago also assumes no liability for improper or incorrect use of materials or information contained on its web site. All materials that appear on the City of Chicago web site are distributed and transmitted as is, without warranties of any kind, either express or implied, and subject to the terms and conditions stated in this disclaimer.