



City of Chicago



O2015-4478

Office of the City Clerk

Document Tracking Sheet

Meeting Date:	5/20/2015
Sponsor(s):	Reilly (42)
Type:	Ordinance
Title:	Grant(s) of privilege in public way for Macy's - light fixtures
Committee(s) Assignment:	Committee on Transportation and Public Way

ORDINANCE
MACY'S
Acct. No. 32101 - 1
Permit No. 1118894

Be It Ordained by the City Council of the City of Chicago:

SECTION 1. Permission and authority are hereby given and granted to MACY'S, upon the terms and subject to the conditions of this ordinance to maintain and use, as now constructed, seventy-six (76) Light Fixture(s) projecting over the public right-of-way adjacent to its premises known as 111 N. State St..

Said Light Fixture(s) at N. State measure(s):

Twenty-eight (28) at one (1) foot in length, one (1) foot in width and twenty-two point five (22.5) feet above grade level.

Twenty-eight (28) at one point zero eight (1.08) foot in length, one point zero eight (1.08) foot in width and twenty-two point five (22.5) feet above grade level.

Twenty (20) at four point six (4.6) feet in length, two point eight three (2.83) feet in width and twenty-two point five (22.5) feet above grade level.

The location of said privilege shall be as shown on prints kept on file with the Department of Business Affairs and Consumer Protection and the Office of the City Clerk.

Said privilege shall be constructed in accordance with plans and specifications approved by the Department of Transportation (Division of Project Development).

This grant of privilege in the public way shall be subject to the provisions of Section 10-28-015 and all other required provisions of the Municipal Code of Chicago.

The grantee shall pay to the City of Chicago as compensation for the privilege #1118894 herein granted the sum of one hundred seventy-five (\$175.00) per annum in advance.

A 25% penalty will be added for payments received after due date.

The permit holder agrees to hold the City of Chicago harmless for any damage, relocation or replacement costs associated with damage, relocation or removal of private property caused by the City performing work in the public way.

Authority herein given and granted for a period of five (5) years from and after 11/18/2014.

Alderman _____

Brendan Reilly 42nd Ward

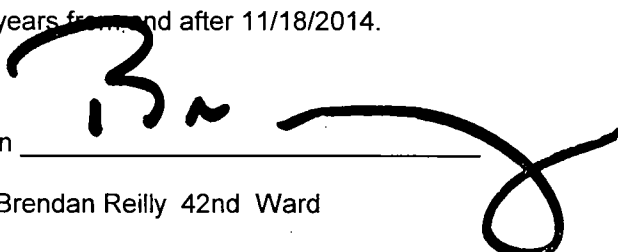
A large, stylized handwritten signature in black ink, appearing to read 'B. Reilly', is written over a horizontal line. The signature is fluid and cursive, with a large loop at the end.

Handwritten scribbles or marks, possibly including the number '5'.

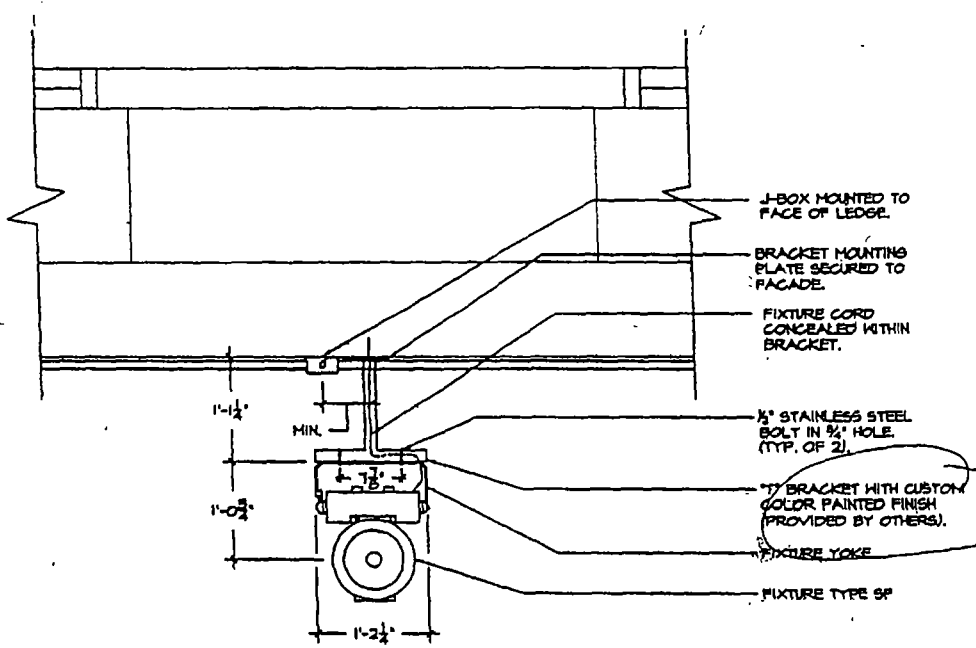

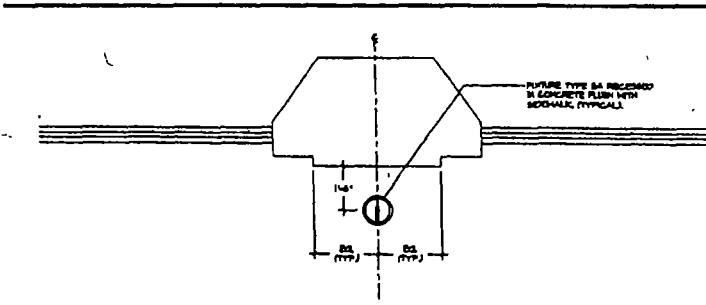

FUTURE TYPE SA REQUIRED
IN CONCRETE FLOOR WITH
SCHEDULE, TYPICAL.

MARK	DATE	DESCRIPTION
3	05.02.03	REVIEW AND
2	04.22.03	IN PROGRES
1	03.17.03	PRICING RE

PROJECT NO: _____
 DRAWN BY: _____
 CHECKED BY: _____
 SCALE: _____
 DATE: _____

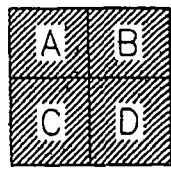

SHEET TITLE

LIGHTING DE

1 1ST FLOOR - TYPE SA PLAN-TYPICAL PILASTER
 SCALE: 3/8" = 1'-0"

LD6