



Office of the City Clerk



O2012-6831

Office of the City Clerk

City Council Document Tracking Sheet

Meeting Date:	10/3/2012
Sponsor(s):	Burnett, Walter (27)
Type:	Ordinance
Title:	Grant(s) of privilege in public way for GEB
Committee(s) Assignment:	Committee on Transportation and Public Way

ORDINANCE
GEB
Acct. No. 370467 - 1
Permit No. 1100876

Be It Ordained by the City Council of the City of Chicago:

SECTION 1. Permission and authority are hereby given and granted to GEB, upon the terms and subject to the conditions of this ordinance to maintain and use two (2) sign(s) projecting over the public right-of-way attached to its premises known as 841 W. Randolph St..

Said sign structure(s) measures as follows; along W. Randolph Street:

One (1) at seventeen (17) feet in length, seven (7) feet in height and twelve (12) feet above grade level.

One (1) at four point three three (4.33) feet in length, three point eight three (3.83) feet in height and ten (10) feet above grade level.

The location of said privilege shall be as shown on prints kept on file with the Department of Business Affairs and Consumer Protection and the Office of the City Clerk.

Said privilege shall be constructed in accordance with plans and specifications approved by the Department of Transportation (Division of Project Development) and Zoning Department - Signs.

This grant of privilege in the public way shall be subject to the provisions of Section 10-28-015 and all other required provisions of the Municipal Code of Chicago.

The grantee shall pay to the City of Chicago as compensation for the privilege #1100876 herein granted the sum of four hundred (\$400.00) per annum in advance.

A 25% penalty will be added for payments received after due date.

The permit holder agrees to hold the City of Chicago harmless for any damage, relocation or replacement costs associated with damage, relocation or removal of private property caused by the City performing work in the public way.

Authority herein given and granted for a period of five (5) years from and after Date of Passage.

Alderman



Walter Burnett Jr. 27th Ward

GEB
 841 W. RANDOLPH ST
 CHICAGO IL. 60607

SIDE VIEW OF SIGN

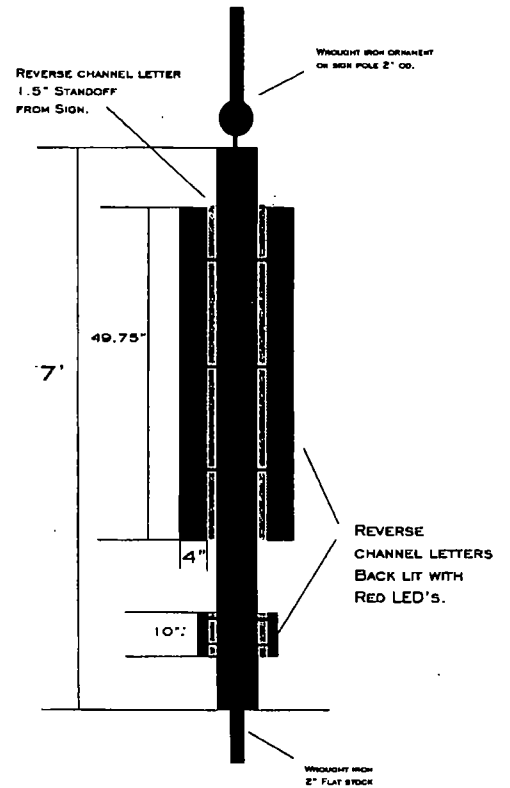

SIDE STREET VIEW

HANGING SIGN ON WROUGHT IRON ARCHITECTURAL POLE.
 REVERSE CHANNEL LETTERS / LOGO ON SIGN FACES.
 1.5" STAND OFF FROM SIGN WITH BACK LIT LEDS FOR HALO EFFECT.

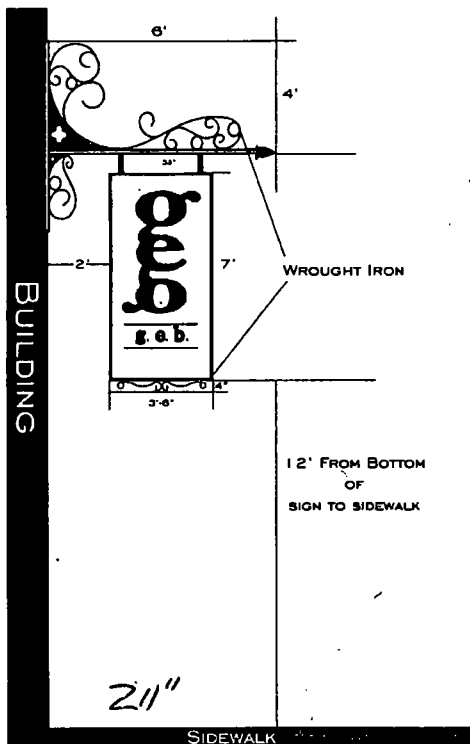

TOP VIEW

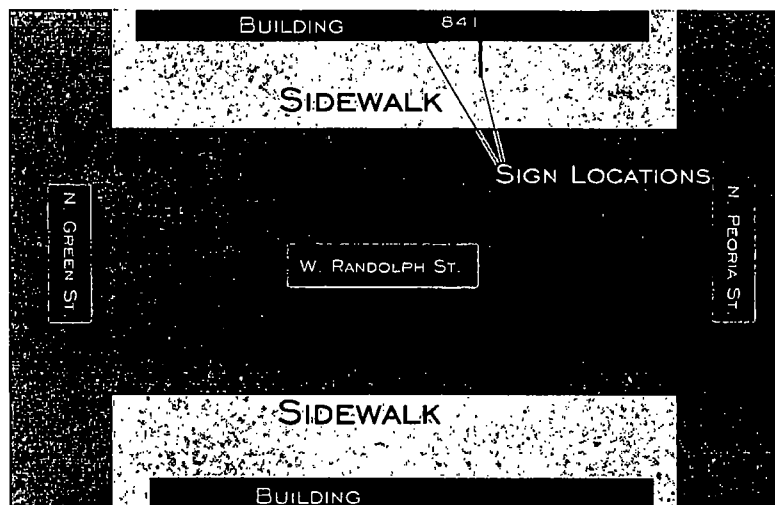

 **PYRAMID**
 DESIGN INC.
 2215 S. ST LOUIS AVE.
 CHICAGO IL. 60623
 (312) 532-7120