



City of Chicago



O2019-8656

Office of the City Clerk

Document Tracking Sheet

Meeting Date:	11/13/2019
Sponsor(s):	La Spata (1)
Type:	Ordinance
Title:	Awning(s) for Boil Cajun Seafood, The
Committee(s) Assignment:	Committee on Transportation and Public Way

ORDINANCE
THE BOIL CAJUN SEAFOOD
Acct. No. 460093 - 1
Permit No. 1141497

Be It Ordained by the City Council of the City of Chicago:

SECTION 1. Permission and authority are hereby given and granted to THE BOIL CAJUN SEAFOOD, upon the terms and subject to the conditions of this ordinance to construct, install, maintain and use one (1) Awning(s) projecting over the public right-of-way adjacent to its premises known as 1805 W. Division St..

Said Awning(s) at W. DIVISION STREET measure(s):

One (1) at twenty-two (22) feet in length, and two (2) feet in width for a total of forty-four (44) square feet.

The location of said privilege shall be as shown on prints kept on file with the Department of Business Affairs and Consumer Protection and the Office of the City Clerk.

Said privilege shall be constructed in accordance with plans and specifications approved by the Zoning Department - Signs.

This grant of privilege in the public way shall be subject to the provisions of Section 10-28-015 and all other required provisions of the Municipal Code of Chicago.

The grantee shall pay to the City of Chicago as compensation for the privilege #1141497 herein granted the sum of fifty (\$50.00) per annum in advance.

A 25% penalty will be added for payments received after due date.

The permit holder agrees to hold the City of Chicago harmless for any damage, relocation or replacement costs associated with damage, relocation or removal of private property caused by the City performing work in the public way.

Authority herein given and granted for a period of five (5) years from and after Date of Passage.

Alderman



Daniel LaSpata 1st Ward

SIGN 2: AWNING

22 FEET

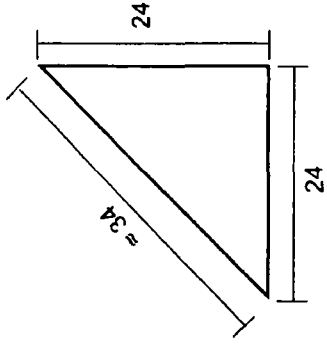

SPECIFICATIONS	
Area	2 H x 22 W
Total Sq.Ft.	44 sq. ft.
Projection	2
TO BE CONFIRM	

SPECIFICATIONS

- 1 AWNING FABRIC MATERIAL
- 2 1 X 1 SQUARE TUBE FRAME
- 3 3/16 GALVANIZED STEEL Z CLIP ATTACHMENT
- 4 APPROPRIATE NON CORROSIVE WALL FASTENER
3/8 IN ZINC PLATED HEX LAG SCREW
SPACING EACH 4 FT
SEE MOUNTING OPTION DETAILS
- 5 #12 TEK SCREW

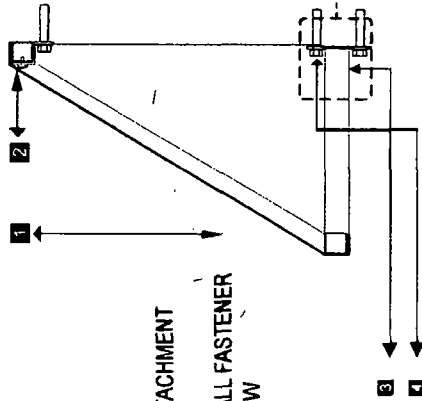

AWNING



GRAPHIC



COLOR SCHEDULE

MOUNTING DETAIL

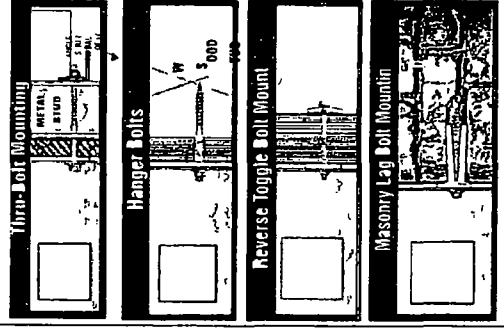

NOTE Elevation drawings are for customer approval only, drawings are not to be used as any installation guide, all dimensions must be verified before installation



Client Name
The Boil Cajun Seafood

Location
1805 W Division St
Chicago IL 60622

Start Date 05/29/19

Last Revision

Job#

Drawing#

Page 5/6

- Client Approval
- Landlord Approval

Sales Rep
kw

Designer
Simon L





Department of Business Affairs and Consumer Protection
Small Business Center - Public Way Use Unit
City Hall - 121 N. LaSalle Street, Room 800 • Chicago, IL 60602
312-74-GOBIZ / 312-744-6249 • (312) 744-1944 (TTY)
<http://www.cityofchicago.org/bacp>

11/13/2019

Alderman Daniel LaSpata
Ward # 01
City of Chicago
City Hall, Room 300
121 North LaSalle Street
Chicago, Illinois 60602

Re: An ordinance to use and maintain a portion of the public right-of-way for **one (1) awning(s)** for **THE BOIL CAJUN SEAFOOD**, adjacent to the premises known as **1805 W. Division St.**.

Dear Alderman **Daniel LaSpata**:

The applicant referenced above has requested the use of the public right-of-way for a **awning(s)**. An ordinance has been prepared by the Department of Business Affairs and Consumer Protection – Small Business Center - Public Way Use Unit for presentation to the City Council. Because this request was made for properties located in your ward, as approved by you as per the attached, I respectfully request that you introduce the attached ordinance at the next City Council meeting.

If you have any questions regarding this ordinance, please contact Anthony Bertuca at (312) 744-5506.

Department of Business Affairs and Consumer Protection