



Office of the City Clerk



O2012-5208

Office of the City Clerk

City Council Document Tracking Sheet

Meeting Date:	7/25/2012
Sponsor(s):	Reilly, Brendan (42)
Type:	Ordinance
Title:	Awning(s) for Gibsons LLC
Committee(s) Assignment:	Committee on Transportation and Public Way

ORDINANCE
GIBSONS L.L.C.
Acct. No. 64192 - 4
Permit No. 1102045

Be It Ordained by the City Council of the City of Chicago:

SECTION 1. Permission and authority are hereby given and granted to GIBSONS L.L.C., upon the terms and subject to the conditions of this ordinance to maintain and use, as now constructed, one (1) Awning(s) projecting over the public right-of-way adjacent to its premises known as 1028 N. Rush St..

Said Awning(s) at Rush St. measure(s):

One (1) at thirteen point three (13.3) feet in length, and ten point six (10.6) feet in width for a total of one hundred forty point nine eight (140.98) square feet.

The location of said privilege shall be as shown on prints kept on file with the Department of Business Affairs and Consumer Protection and the Office of the City Clerk.

Said privilege shall be constructed in accordance with plans and specifications approved by the Zoning Department - Signs.

This grant of privilege in the public way shall be subject to the provisions of Section 10-28-015 and all other required provisions of the Municipal Code of Chicago.

The grantee shall pay to the City of Chicago as compensation for the privilege #1102045 herein granted the sum of fifty (\$50.00) per annum in advance.

A 25% penalty will be added for payments received after due date.

The permit holder agrees to hold the City of Chicago harmless for any damage, relocation or replacement costs associated with damage, relocation or removal of private property caused by the City performing work in the public way.

Authority herein given and granted for a period of five (5) years from and after 06/09/2012.

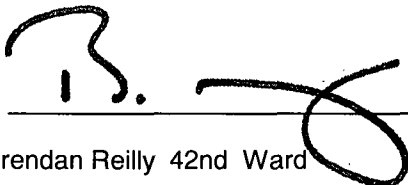
Alderman 
Brendan Reilly 42nd Ward

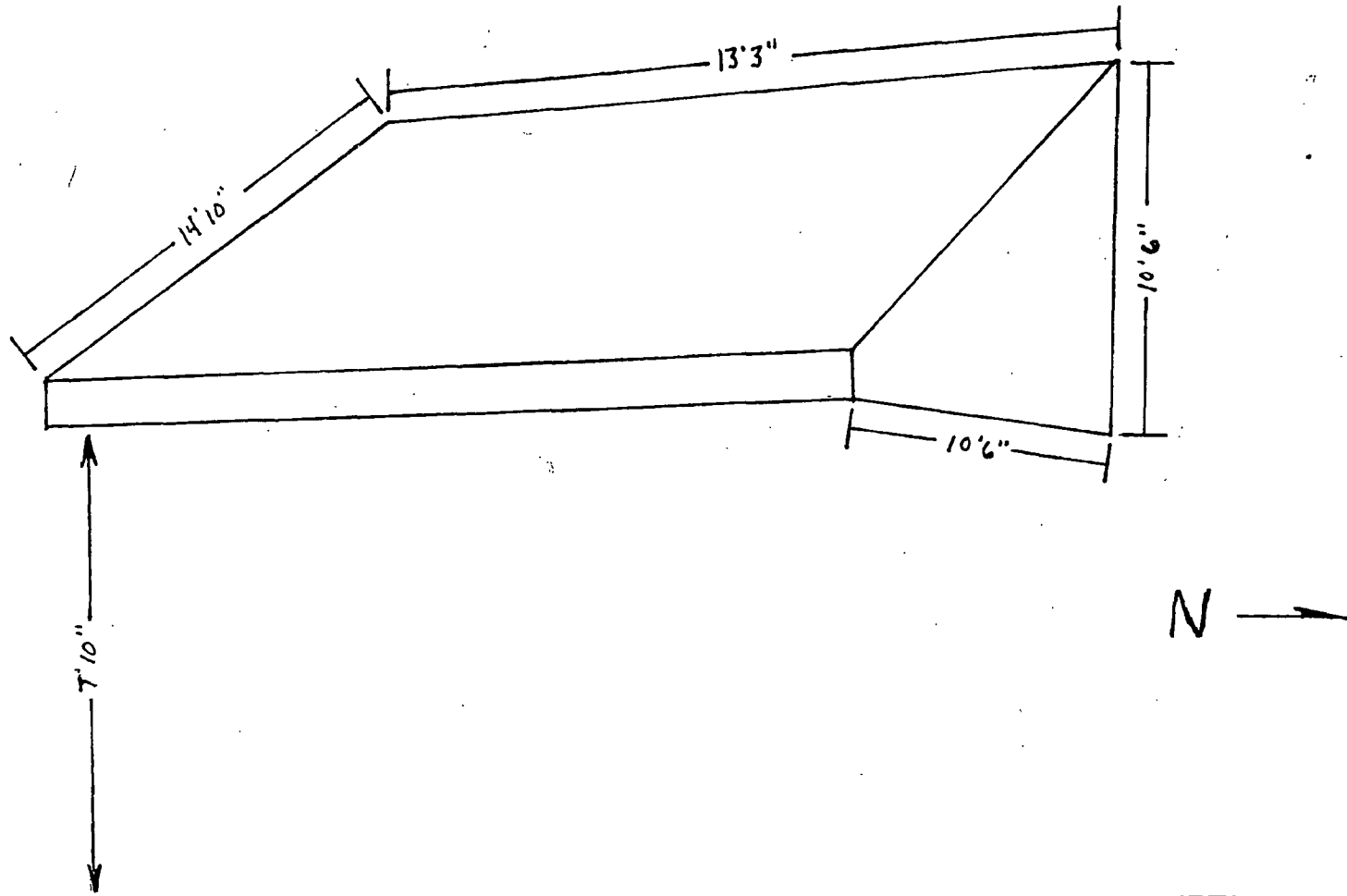

GIBSONS BAR & STEAKHOUSE
1028 N. RUSH ST.