



# City of Chicago



O2014-2882

Office of the City Clerk

## Document Tracking Sheet

<b>Meeting Date:</b>	4/2/2014
<b>Sponsor(s):</b>	Tunney (44)
<b>Type:</b>	Ordinance
<b>Title:</b>	Grant(s) of privilege in public way for Lakeview Chamber of Commerce
<b>Committee(s) Assignment:</b>	Committee on Transportation and Public Way

ORDINANCE

Lakeview Chamber of Commerce, Inc.
Acct. No. 270704 - 49
Permit No. 1110388

City of Chicago
Permit No. 1110388

Be It Ordained by the City Council of the City of Chicago:

SECTION 1. Permission and authority are hereby given and granted to Lakeview Chamber of Commerce, upon the terms and subject to the conditions of this ordinance to construct, install, maintain and use two (2) Bicycle Rack(s) on the public right-of-way adjacent to its premises known as 3235-3243 N. Ashland Ave.

Said Bicycle Rack(s) at Ashland measure(s): Two (2) at five (5) feet in length, and: point one seven (.17) feet in width for a total of one point seven (1.7) square feet.

The location of said privilege shall be as shown on prints kept on file with the Department of Business Affairs and Consumer Protection and the Office of the City Clerk.

Said privilege shall be constructed in accordance with plans and specifications approved by the Department of Planning and Development and Department of Transportation (Division of Project Development).

This grant of privilege in the public way shall be subject to the provisions of Section 10-28-015 and all other required provisions of the Municipal Code of Chicago.

The grantee shall pay to the City of Chicago as compensation for the privilege #1110388 herein granted the sum of zero (\$0.00) per annum in advance.

A 25% penalty will be added for payments received after due date.

The permit holder agrees to hold the City of Chicago harmless for any damage, relocation or replacement costs associated with damage, relocation or removal of private property caused by the City performing work in the public way.

Authority herein given and granted for a period of five (5) years from and after Date of Passage.

Alderman Thomas Tunney
Thomas Tunney 44th Ward

# BROADWAY RACK

## Specifications and Space Use

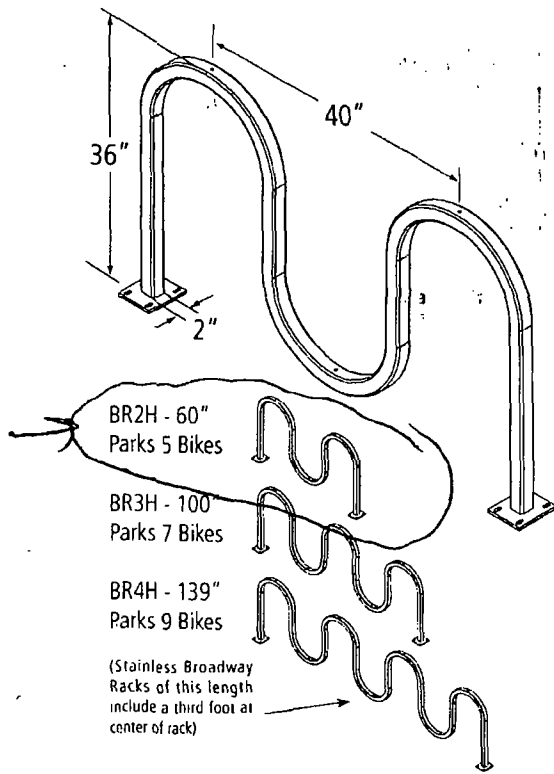

### Product

Dero Broadway Rack  
As manufactured by Dero Bike Racks

BR2H: 5 Bikes  
BR3H: 7 Bikes  
BR4H: 9 Bikes

### Materials

2" x 2" x 3/16" square tube - mild steel  
2" x 2" x 11g square tube - stainless steel

### Finishes

An after fabrication hot dipped galvanized finish is our standard option. 250 TGIC powder coat colors, thermoplastic coating, and stainless steel finishes are also available as alternate options.

Our powder coat finish assures a high level of adhesion and durability by following these steps:

1. Sandblast
2. Epoxy primer electrostatically applied
3. Final thick TGIC polyester powder coat

Stainless Steel: 304 grade stainless steel material finished in either a high polished shine or a satin finish.

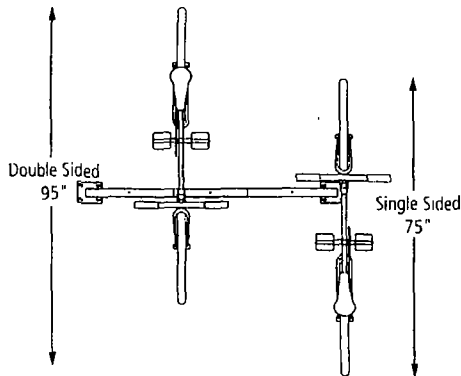

### Installation Methods

**In ground mount** is embedded into concrete base. Specify in ground mount for this option.

**Surface mount** has two 5.25" x 5.5" foot plates with 4 anchors per foot. Specify foot mount for this option. A **rail mounted** (freestanding) option is also available.

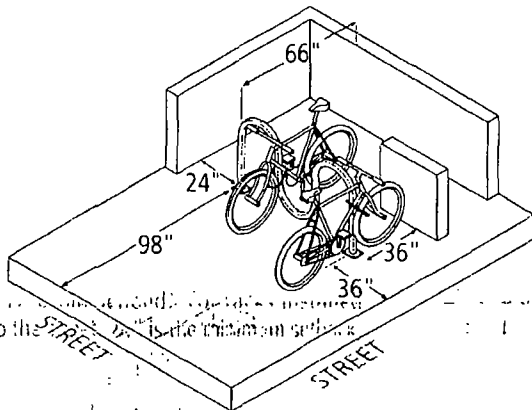
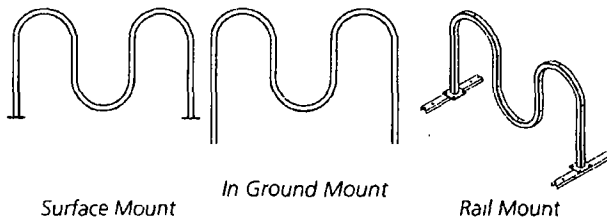

### Space Use and Setbacks

**Wall Setback:** A minimum of 27" should be left between the wall and the long side of the rack. 36" is the recommended setback.

**Street Setback:** For racks set parallel to the street, a 98" setback is recommended. For racks installed perpendicular to the street, 24" is the minimum setback. 36" is recommended.

**Between Racks:** For racks set next to each other, 24" is the minimum setback. 36" is recommended.

