



City of Chicago



O2019-3674

Office of the City Clerk

Document Tracking Sheet

Meeting Date:	5/16/2019
Sponsor(s):	Burnett (27)
Type:	Ordinance
Title:	Grant(s) of privilege in public way for Alhambra Palace Restaurant - sign
Committee(s) Assignment:	Committee on Transportation and Public Way

Direct
27

ORDINANCE
ALHAMBRA PALACE RESTAURANT
Acct. No. 289871 - 1
Permit No. 1138641

Be It Ordained by the City Council of the City of Chicago:

SECTION 1. Permission and authority are hereby given and granted to ALHAMBRA PALACE RESTAURANT, upon the terms and subject to the conditions of this ordinance to maintain and use two (2) sign(s) projecting over the public right-of-way attached to its premises known as 1240 W. Randolph St..

Said sign structure(s) measures as follows; along W. Randolph Street:

One (1) at six (6) feet in length, ten (10) feet in height and fourteen (14) feet above grade level.

One (1) at fifteen (15) feet in length, six (6) feet in height and seventeen (17) feet above grade level.

The location of said privilege shall be as shown on prints kept on file with the Department of Business Affairs and Consumer Protection and the Office of the City Clerk.

Said privilege shall be constructed in accordance with plans and specifications approved by the Department of Transportation (Division of Project Development) and Zoning Department - Signs.

This grant of privilege in the public way shall be subject to the provisions of Section 10-28-015 and all other required provisions of the Municipal Code of Chicago.

The grantee shall pay to the City of Chicago as compensation for the privilege #1138641 herein granted the sum of six hundred (\$600.00) per annum in advance.

A 25% penalty will be added for payments received after due date.

The permit holder agrees to hold the City of Chicago harmless for any damage, relocation or replacement costs associated with damage, relocation or removal of private property caused by the City performing work in the public way.

Authority herein given and granted for a period of five (5) years from and after Date of Passage.

Alderman _____

Walter Burnett Jr. 27th Ward

Front-Lit Channel Letters w/LED Illumination • Individually Mounted • Alhambra Palace • Chicago • IL



Front View

A Front-Lit, Plex-Face Channel Letters w/ LED, Individually Mounted • Front View

SCALE 0/0" = 1' 0" For Production / For Presentation

QUANTITY	ONE (1)
Overall Height	6
Overall Length	15
Total Sq Ft	90 ft ²
Returns	040 x 5 3 Aluminum Coil Painted Black
Backs	063 Aluminum
Trimcap	Black
Face	#2447
First surface translucent vinyl	FDC UC 900-434-T Vivid Red

WHITE interiors for increased illumination

CHANNEL LETTER - TYPICAL SECTION - FRONT-LIT PLASTIC FACE

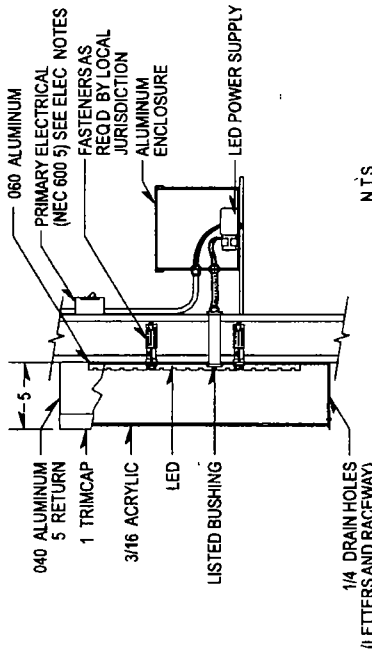

ELECTRICAL NOTES

- Sign Company DOES NOT provide primary electrical to sign.
- Power to the sign must be done by a licensed electrical contractor or licensed electrician.
- Each sign must have:
 1. A minimum of one dedicated 120V 20A circuit
 2. Junction box installed within 6 feet of sign
 3. Three wires: Line, Ground, Neutral

PLEASE REVIEW DRAWINGS FOR ACCURACY IN COLOR LAYOUT SPELLING APPROVAL STATES ALL CONTENT REPRESENTED IN THIS PROOF IS CORRECT



5500 N Kedzie Ave Chicago IL 60625
773 267 6007 | sales@tfasigns.com

Client Name
Alhambra Palace

Location
1240 W Randolph St
Chicago IL 60607

Start Date 01/25/2019
Last Revision 02/11/2019
Job# 00000
Drawing# 00000a v1 s1 / e1
Page 2 of 3

- Client Approval
- Landlord Approval

Sales Rep
Seung Park

Designer
Dante Bridges





04/10/2019

Alderman Walter Burnett Jr.
Ward # 27
City of Chicago
City Hall, Room 300
121 North LaSalle Street
Chicago, Illinois 60602

Re: An ordinance to use and maintain a portion of the public right-of-way for **two (2) sign(s)** for **ALHAMBRA PALACE RESTAURANT**, adjacent to the premises known as **1240 W. Randolph St.**

Dear Alderman **Walter Burnett Jr.**:

The applicant referenced above has requested the use of the public right-of-way for a **sign(s)**. An ordinance has been prepared by the Department of Business Affairs and Consumer Protection – Small Business Center - Public Way Use Unit for presentation to the City Council. Because this request was made for properties located in your ward, as approved by you as per the attached, I respectfully request that you introduce the attached ordinance at the next City Council meeting.

If you have any questions regarding this ordinance, please contact Anthony Bertuca at (312) 744-5506.

Department of Business Affairs and Consumer Protection