



City of Chicago



O2014-7800

Office of the City Clerk

Document Tracking Sheet

Meeting Date:	9/10/2014
Sponsor(s):	Tunney (44)
Type:	Ordinance
Title:	Grant(s) of privilege in public way for Lakeview Chamber of Commerce - 3300 N Southport Ave
Committee(s) Assignment:	Committee on Transportation and Public Way

ORDINANCE
LAKEVIEW CHAMBER OF COMMERCE
Acct. No. 270704 - 54
Permit No. 1114660

Be It Ordained by the City Council of the City of Chicago:

SECTION 1. Permission and authority are hereby given and granted to LAKEVIEW CHAMBER OF COMMERCE, upon the terms and subject to the conditions of this ordinance to construct, install, maintain and use one (1) Bicycle Rack(s) on the public right-of-way adjacent to its premises known as 3300 N. Southport Ave..

Said Bicycle Rack(s) at N. Southport Avenue measure(s):

One (1) at two point nine two (2.92) feet in length, and point one seven (.17) feet in width for a total of point five (.5) square feet.

The location of said privilege shall be as shown on prints kept on file with the Department of Business Affairs and Consumer Protection and the Office of the City Clerk.

Said privilege shall be constructed in accordance with plans and specifications approved by the Department of Planning and Development and Department of Transportation (Division of Project Development).

This grant of privilege in the public way shall be subject to the provisions of Section 10-28-015 and all other required provisions of the Municipal Code of Chicago.

The grantee shall pay to the City of Chicago as compensation for the privilege #1114660 herein granted the sum of zero (\$0.00) per annum in advance.

A 25% penalty will be added for payments received after due date.

The permit holder agrees to hold the City of Chicago harmless for any damage, relocation or replacement costs associated with damage, relocation or removal of private property caused by the City performing work in the public way.

Authority herein given and granted for a period of five (5) years from and after Date of Passage.

Alderman

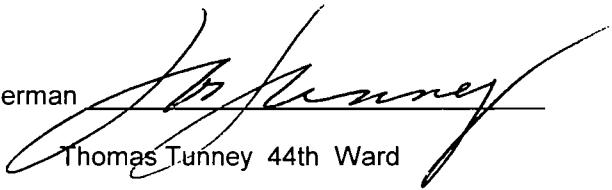

Thomas Tunney 44th Ward

DOWNTOWN RACK

Specifications and Space Use

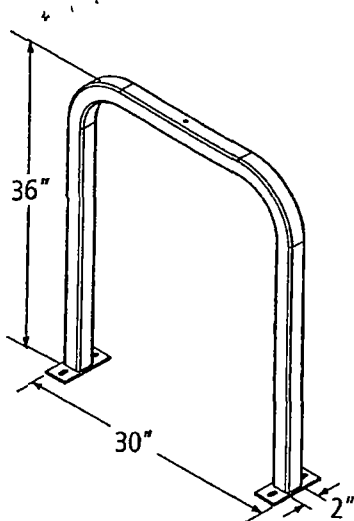

Product Dero Downtown Rack
As manufactured by Dero Bike Racks

Capacity 2 Bikes

Materials 2" x 2" x 3/16" square tube - mild steel
2" x 2" x 11g square tube - stainless steel

Finishes An after fabrication hot dipped galvanized finish is our standard option. 250 TGIC powder coat colors, thermoplastic coating, PVC dip, and stainless steel finishes are also available as alternate options.

Our powder coat finish assures a high level of adhesion and durability by following these steps:

1. Sandblast
2. Epoxy primer electrostatically applied
3. Final thick TGIC polyester powder coat

Stainless Steel: 304 grade stainless steel material finished in either a high polished shine or a satin finish.

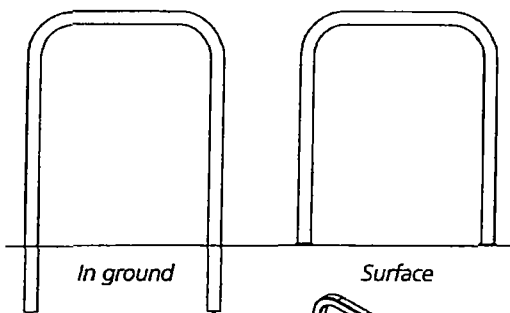

Installation Methods **In ground mount** is embedded into concrete base. Specify in ground mount for this option.

Foot Mount has two 2.5" x 6" x 25" feet with two anchors per foot. Specify foot mount for this option.

Rail Mounted Downtown Racks are bolted to two parallel rails which can be left freestanding or anchored to the ground. Rails are heavy duty 3" x 1.4" x 3/16" thick galvanized mounting rails. Specify rail mount for this option.

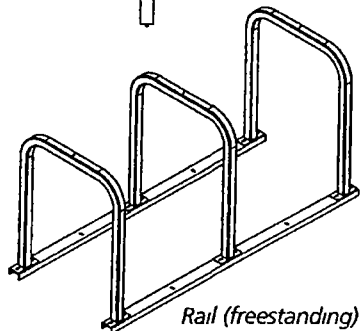

Space Use and Setbacks **Wall Setbacks:** For racks set parallel to a wall.

Minimum: 24"
Recommended: 36"

For racks set perpendicular to a wall:

Minimum: 28"
Recommended: 42"

Distance Between Racks:

Minimum: 24"
Recommended: 36"

Street Setbacks:

Minimum: 24"
Recommended: 36"

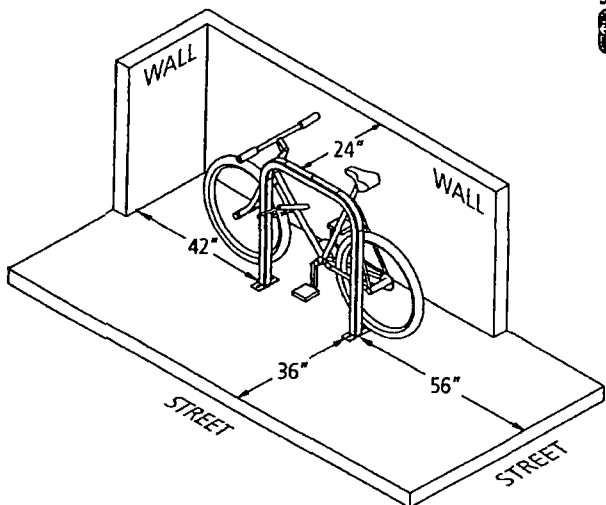



Department of Business Affairs and Consumer Protection
Small Business Center - Public Way Use Unit
City Hall - 121 N. LaSalle Street, Room 800 • Chicago, IL 60602
(312)-74-GOBIZ (312-744-6249) • (312) 744-1944 (TTY)
<http://www.cityofchicago.org/bacp>

09/10/2014

Alderman **Thomas Tunney**
Ward # 44
City of Chicago
City Hall, Room 203
121 North LaSalle Street
Chicago, Illinois 60602

Re: An ordinance to use and maintain a portion of the public right-of-way for **one (1) bicycle rack(s)** for **LAKEVIEW CHAMBER OF COMMERCE**, adjacent to the premises known as **3300 N. Southport Ave.**.

Dear Alderman **Thomas Tunney**:

The applicant referenced above has requested the use of the public right-of-way for a **bicycle rack(s)**. An ordinance has been prepared by the Department of Business Affairs and Consumer Protection – Small Business Center - Public Way Use Unit for presentation to the City Council. Because this request was made for properties located in your ward, as approved by you as per the attached, I respectfully request that you introduce the attached ordinance at the next City Council meeting.

If you have any questions regarding this ordinance, please contact Anthony Bertuca at (312) 744-5506.

Department of Business Affairs and Consumer Protection