



City of Chicago



O2018-3377

Office of the City Clerk

Document Tracking Sheet

Meeting Date:	4/18/2018
Sponsor(s):	Reilly (42)
Type:	Ordinance
Title:	Canopy(s) for Hilton Garden Inn Chicago Downtown/Manificent Mile
Committee(s) Assignment:	Committee on Transportation and Public Way

ORDINANCE
HILTON GARDEN INN CHICAGO DOWNTOWN/MAGNIFICENT MILE
Acct No. 373699 - 1
Permit No. 1127923

Be It Ordained by the City Council of the City of Chicago:

SECTION 1. Permission and authority are hereby given and granted to HILTON GARDEN INN CHICAGO DOWNTOWN/MAGNIFICENT MILE, upon the terms and subject to the conditions of this ordinance to maintain and use, as now constructed, two (2) Canopy(s) projecting over the public right-of-way adjacent to its premises known as 10 E. Grand Ave..

Said Canopy(s) at E. Grand Avenue measure(s):

Two (2) at twenty-three point five (23.5) feet in length, and seven point two five (7.25) feet in width for a total of three hundred forty point seven five (340.75) square feet.

The location of said privilege shall be as shown on prints kept on file with the Department of Business Affairs and Consumer Protection and the Office of the City Clerk.

Said privilege shall be constructed in accordance with plans and specifications approved by the Zoning Department - Signs.

This grant of privilege in the public way shall be subject to the provisions of Section 10-28-015 and all other required provisions of the Municipal Code of Chicago.

The grantee shall pay to the City of Chicago as compensation for the privilege #1127923 herein granted the sum of one hundred (\$100.00) per annum in advance.

A 25% penalty will be added for payments received after due date.

The permit holder agrees to hold the City of Chicago harmless for any damage, relocation or replacement costs associated with damage, relocation or removal of private property caused by the City performing work in the public way.

Authority herein given and granted for a period of five (5) years from and after Date of Passage.

Alderman _____

Brendan Reilly 42nd Ward

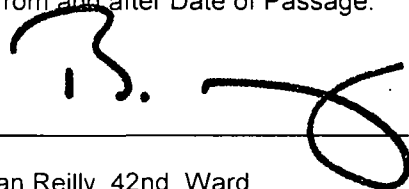

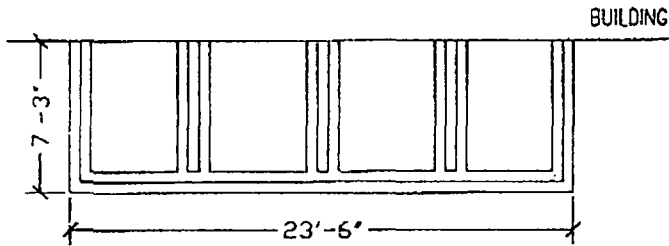

GRAND CANOPY PLAN

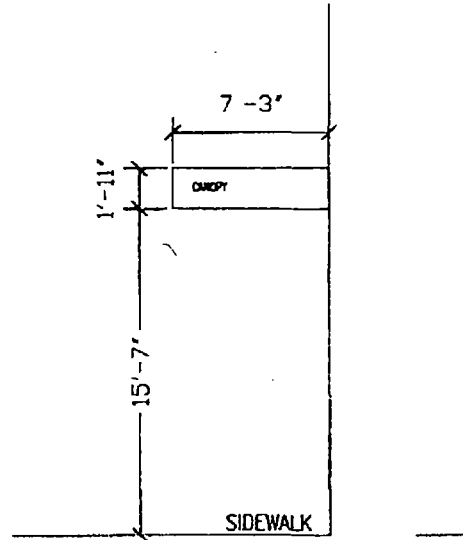

GRAND CANOPY ELEVATION

1 GRAND AVENUE CANOPY 1 PLAN
 A150 1/8" = 1'-0"

2 GRAND AVENUE CANOPY 1 ELEV
 A150 1/8" = 1'-0"

COPYRIGHT 2016 ALEXANDER & ASSOCIATES, LTD

 ALEXANDER & ASSOCIATES, LTD ARCHITECTS 11 E GRAND STREET, 11TH FLOOR CHICAGO, IL 60611 TEL: 312.842.1000	JUNSTONE EAST GRAND LESSEE INT	DATE	SHEET #
	10 EAST GRAND	MARCH 15 2016	A150
	CHICAGO IL 60611		SCALE
			NT
			A&A 1601