



Office of the Chicago City
Clerk



Or2011-680

Office of the City Clerk

City Council Document Tracking Sheet

Meeting Date:	7/6/2011
Sponsor(s):	Zaiewski, Michael R. (23)
Type:	Order
Title:	Issuance of Sign(s)/Signboard(s) at 6190 S Archer Ave
Committee(s) Assignment:	Committee on Zoning, Landmarks and Building Standards

Committee on Buildings

(signs)

**ORDERED, That the Commissioner of Buildings is hereby directed
to issue a sign permit to:**

**Chi-Town Signs
1231 Channahon Rd.
Rockdale, IL. 60436**

**for the erection of a sign/signboard over 24 feet and / or over 100
square feet (in area of one face) at:**

**Family Dollar
6190 S. Archer Ave.
Chicago, Illinois 60638**

Dimensions: length 29ft. 6 in. height 4ft. 0in.

Height above grade / roof to top of sign 16 ft. 0 in.

TOTAL SQUARE FOOT AREA 278 sq. ft.

**Such sign(s) shall comply with all applicable provisions of
TITLE 17 of the Chicago Zoning Ordinance and all other
Applicable provisions of the Municipal Code of the City of Chicago
Governing the construction and maintenance of outdoor signs,
signboards and structures.**

**City Council Meeting
July 8, 2011**



**Michael R. Zaiewski
23rd Ward, Alderman**



CITY OF CHICAGO

DEPARTMENT OF BUILDINGS

Sign Permit Application

APPROVAL NUMBER	APPLICATION NUMBER 100378278	ANNUAL FEE	WORK CODE	DRAWINGS ATTACHED <input type="checkbox"/> YES <input type="checkbox"/> NO
DATE OF APPLICATION 01/10/2011	ADDRESS OF SIGN 6190 S ARCHER AVE, 60638-		TYPE OF SIGN ROOF	
BUILDING	ORIGINAL PERMIT NUMBER	LENGTH 29	FEET 6	DEPTH 4
TYPE OF PERMIT NEW CONSTRUCTION (SIGN)		AREA 118	WIDTH	IN 0
PAYOR OF ANNUAL INSPECTION CARDENAS, CESAR 1231 CHANNAHON ROCKDALE, IL 60436 (815)730-9555		HEIGHT 150		PL. IN 12
SIGN MANUFACTURER ALLEN INDUSTRIES		SHAPE OF SIGN REGULAR		
ADDRESS WHERE SIGN CAN BE SEEN FROM TO INSPECTION		SIGN WILL READ FAMILY DOLLAR		
TICKET NUMBER 0	REINSPECTION CONTROL NUMBER	NO. OF LAMPS 17	TOTAL WATTAGE 60	
TYPE OF SUPPORT FOR SIGN ROOF STRUCTURE		TYPE OF LAMP FLUORCSCENT		
SKIN/BOARD SUPPORT MEMBERS STEEL		NO. OF DAL LAST/TRANSFORMERS		
ANNUAL FEE		INPUT OF TRANSFORMERS		
CONSTRUCTION FEE	200.00	CONTRACTOR WILL INSTALL <input checked="" type="checkbox"/> YES <input type="checkbox"/> NO		
1017 B FEE		FEEBOOKS <input type="checkbox"/> CUSTOMER LEADS <input type="checkbox"/>		
TOTAL FEE	200.00	TYPE OF SWITCH KNIFE		
AMOUNT PAID	200.00	LOCATION OF SWITCH OUTSIDE SIGN		
BALANCE DUE		SIGN LOCATION INSTALL FAMILY DOLLAR PACKAGE		
<p>The undersigned certifies that the statements in this application are true and correct and that all work done under this proposed permit will conform to the requirements of the Chicago Municipal Code.</p>				

ISS. NO. E92792	ISS. NO. N93998
ELECT. CONTR. PALOMINO CONSTRUCTION, INC. ELECTR	SIGNER FOR CHI-TOWN SIGNS SIGNER
ADDRESS 5546 W. WINDSOR ST. CHICAGO, IL 60630-	ADDRESS 1231 CHANNAHON RD ROCKDALE IL, 60436
SUBMITTER SIGNATURE	SIGNATURE

The permit issued on this application will authorize only signs here applied for. If other signs are to be erected they must be covered by additional permits.

City of Chicago
Richard M. Daley, Mayor



Department of Buildings
Richard Monocchio, Commissioner

TYPE OF BUSINESS
COMMERCIAL Other: _____
 Name _____
 L.I.F. #: _____
 Renewal Date: _____

SIGN BOND REQUIRED? YES
 COUNCIL ORDER REQUIRED YES

Project Over:
 Private Property
 Public Way Grant Permit #: _____
 Planned Development/Manufacturing PMD/PD#: _____
 Zoning District: **B3** Other: **B3-1**

IS SPECIAL PERMISSION REQUIRED FROM CHIEF ELECTRICAL
 YES
 IF YES, ATTACH LETTER OF REQUEST

TYPE OF SIGN:
 ADVERTISING ILLUMINATED MOVEABLE
 BUSINESS FLASHING

TIME STAMP

TOTAL STREET FRONTAGE OF LOT (IN FEET) _____ 77
 TOTAL AREA OF NEW SIGN (SQ.FT.) _____ 118
 TOTAL AREA OF ALL SIGNS ON LOT (SQ.FT.) _____ 278
 HEIGHT OF SIGN ABOVE GRADE (TO TOP) _____ 1611 0in
 DISTANCE OF CURB LINE OFFER EDGE (ft) _____ 5
 DISTANCE OF STRUCTURE INNER EDGE (ft) _____ 5

SIGN CLERK _____ APPROVED FOR PERMIT _____

DISTANCE FROM (ft):
 A. PUBLIC PARK (OVER 10 ACRES) _____
 B. EXPRESSWAY (IF LESS THAN 1,000 FT.) _____
 C. RESIDENCE DISTRICT (ADVERTISING SIGNS ONLY) _____
 IF REPLACEMENT SIGN OR CHANGE OF FACE, WHAT DOES THE EXISTING SIGN READ?
 Original Payee: _____

REMARKS

Landmark Hold: Status: _____

ZONING (OFFICE USE ONLY)

CONFORMS
 TO ZONING ORDINANCE
 This Approval of Application for signs
 shall not be held to permit or be an
 approval of any violation of the provisions.
FEB 24 2011
 of the Chicago Zoning Ordinance, or any other
 requirements of the Municipal Code of the
 City of Chicago
 ZONING ADMINISTRATOR

December 17, 2010
Re: Family Dollar proposed signage
6190 S. Archer Ave.
Chicago, IL 60638

Dear Sir:

Family Dollar has notified Allen Industries that a new store is planned for the above referenced location. Allen has had the opportunity to survey the space, check local sign codes, and recommend a standard sign package to Family Dollar. Drawings for the proposed sign package are attached.

We understand that often properties have their own specific sign criteria, and would like to inquire if the signage proposed for this store may be affected by any such Master Signage Criteria. We would appreciate your acknowledgement of receipt of this letter and signage renderings by signing below.

Thank you for your consideration and cooperation.

Approval:	
Date:	December 9, 2010

Landlord/Landlord Representative's Signature

Name: Thomas Cronin
 Company: Ess Store, Inc.
 Address: 6190 S. Archer Ave.
Chicago, IL 60638
 Phone: 680.279.5550

Notes:

Please sign and return to Allen Industries, Inc. via facsimile (330) 606-2010.

Christa Wozniak
 Allen Industries, Inc.
 6434 Burnt Poplar Road
 Greensboro, NC 27409
 (800) 967-2553 ext. 3024
 (336) 668-2791 ext. 3024
 (336) 605-2010 Fax
Christa.Wozniak@allcnindustries.com

704-814-4295

ZONE Classification		Ordinance Number			Ordinance Date						
B3-1											
Building Id	From Add	To Add	Dir	Street	Type	Stories	Units	Built	Sq.Ft.	Condition	Vacancy
486663	6177	6177	S	ARCHER AVE		1		1962	2200	SOUND	
Map Index				Page Number							
12-M				1388							
PIN					From Address	To Address	Dir Street Type Suffix				
Cook County Assessor Cook County Recorder of Deeds CNT 19083320090000					6177	6177	S ARCHER AVE				
Ward	Alderman		Phone			Address					
23	MICHAEL R. ZALEWSKI		773-582-4444			6247 S ARCHER AVE					

Close Window

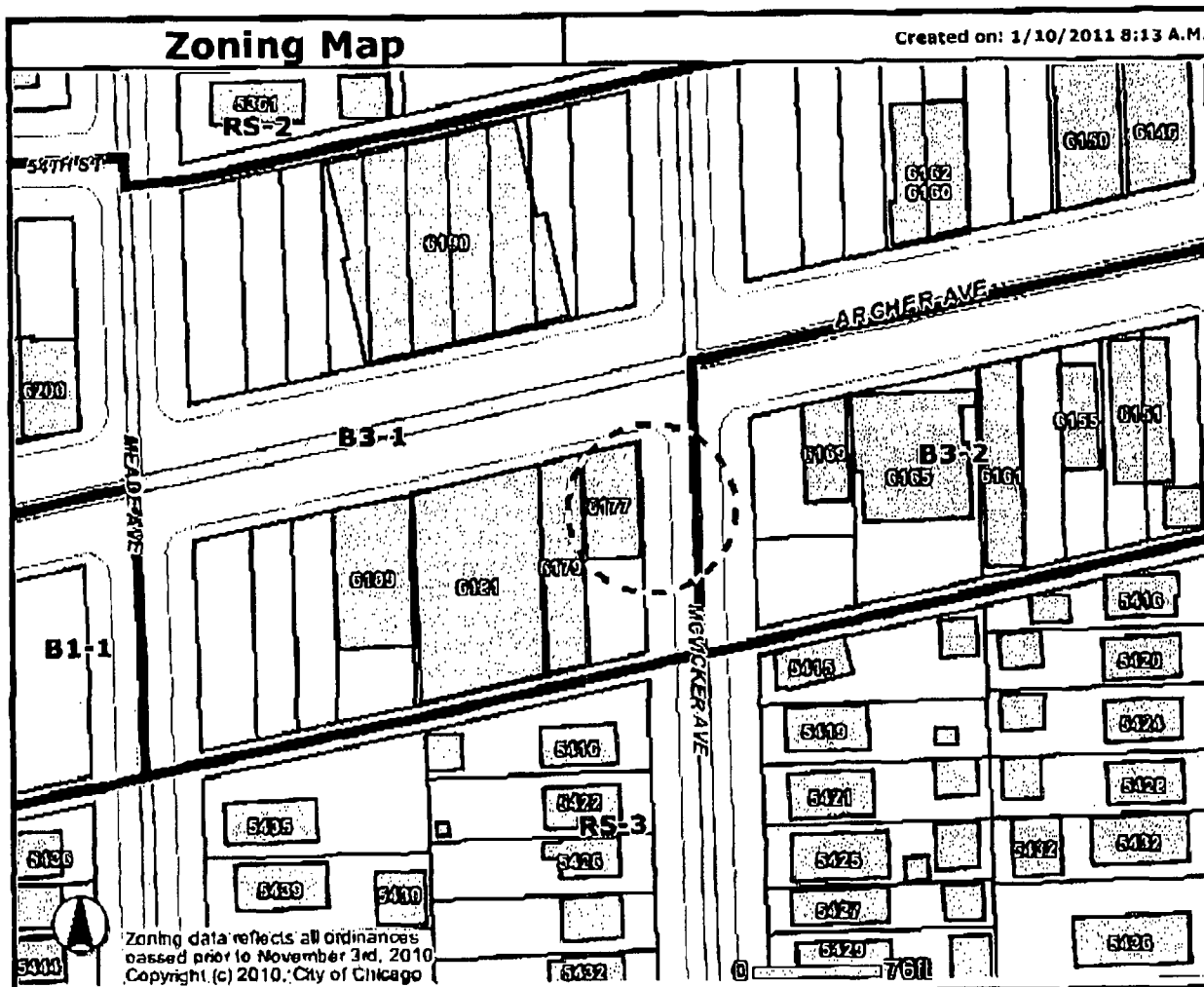

Address

6177 S ARCHER AVE

Zoning

- Business
- Commercial
- Manufacturing
- Residential
- Planned Development
- Planned Manufacturing
- Downtown Core
- Downtown Service
- Downtown Mixed
- Downtown Residential
- Transportation
- Parks & Open Space
- Zoning Boundaries

Historic Preservation

- CHICAGO LANDMARKS**
- Chicago Landmarks
- Landmark Districts
- Chicago Historic Resources Survey - Buildings subject to Demolition-Defer Ordinance**
- Red
- Orange
- Forest Preserve
- Text Street Names
- Municipalities

- Lakefront
- Pedestrian Streets
- Buildings
- Parcels
- Streets
- Curbs
- Water
- Cemetery
- City Boundary

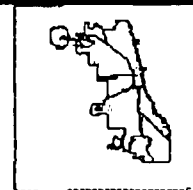

Information provided on the City of Chicago web site should not be used as a substitute for legal, accounting, real estate, business, tax, or other professional advice. The City of Chicago assumes no liability for any damages or loss of any kind that might arise from the use of, misuse of, or the inability to use the City web site and/or the materials contained on the web site. The City of Chicago also assumes no liability for improper or incorrect use of materials or information contained on its web site. All materials that appear on the City of Chicago web site are distributed and transmitted as is, without warranties of any kind, either express or implied, and subject to the terms and conditions stated in this disclaimer.

17735823332

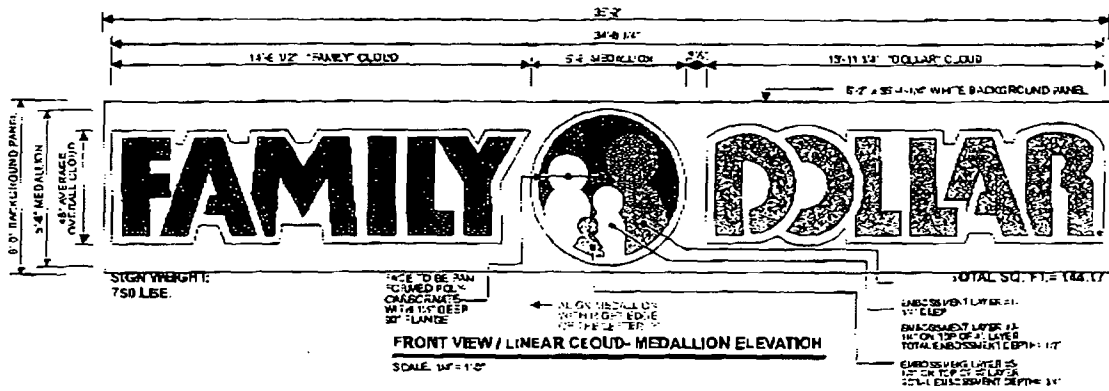

GENERAL SPECIFICATIONS:

CLOUD FORMAT LOGO MEDALLION AND WORD FORMS AS PER FIXED APPROVED DRAWINGS BASED ON THE 48" CLOUDS ILLUSTRATED. CLOUD FORMAT SHALL ENCOMPASS THE LOGO MEDALLION AND THE FAMILY DOLLAR STANDARD LOGO FORMS ALLOWING THE USE OF T-12 NO. 0 FLUORESCENT LAMPING SYSTEM W/ UUPS, SOCKETS, WIRE TRAYS AND ELECTRONIC BALLASTS U.L. APPROVED. CLOUD SIGNS SHALL BE ASSEMBLED FROM .220" THICK ABS BACKS AND RETURNS. FACE SHALL BE FORMED .177" THICK CLEAR GRADE POLYCARBONATE WITH ALL COLORS APPLIED SECOND SURFACE. FACE IS HELD IN WITH FASTENERS THROUGH THE INTERIOR VOUNDED UP.

MOUNTING PROVIDED VIA TYP. (2) SETS OF CONTINUOUS 2 PART 12 GA. 576L x 2" BAR MOUNTING BRACKET ATTACHED WITH 1/2" DIA. S.S. THRU BOLTS.

LOGO MEDALLION: #457 UNIBE RED (ACRYL), #165 ORANGE (PVS), AND WHITE TRANSLUCENT
 FAMILY: #437 UNIBE RED (ACRYL)
 DOLLAR: #165 ORANGE (PVS)
 BACKROUND BORDER & FLANGE - WHITE TRANSLUCENT
 S: #165 ORANGE (PVS)
 TLT: #165 ORANGE (PVS)
 RETURNS & BACKS - WHITE
 ALL CLOUD FACE MTC. SCREW HEADS TO BE WHITE



FACE MATERIAL BURN RATE:
UL 9A FLAM CLASS RATING- S4V-2

SCALE BASED ON TABLOID SIZE PAPER

HEXHEAD STAINLESS 316L FASTENERS PAINTED WHITE SATIN FINISH

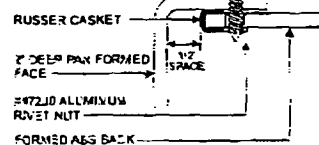

FACE MTC. DETAIL
SCALE: ELEVATION - SCALE N.T.S.

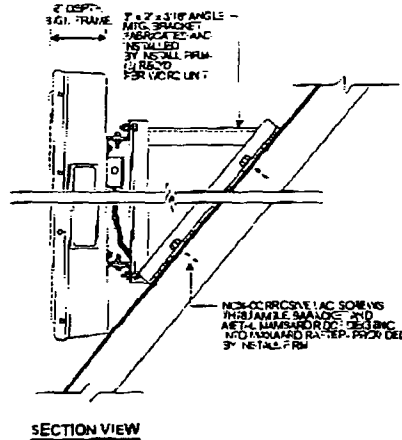

Project Information

Client: Family Dollar

Location: 5190 S. Archer Ave. Chicago, IL

900-3118, Chicago, IL (LIN Cloud) around N.E. Corner

Task: Design Project Manager: MP

Date / Description

10/07/10 Issue Date

Client Review Status

Approved Approved in Part Not Approved Rejected Revised Resubmitted

Date: Date: Date:

Notes

IF A BURN RATE IS NOT PROVIDED FOR THE FACE MATERIAL IT SHALL BE CONSIDERED TO BE A BURN RATE OF 0.0012 BTU/HR/INCH². ALL MATERIALS SHALL BE TESTED TO MEET OR EXCEED THE REQUIREMENTS OF THE UL 9A STANDARD. ALL MATERIALS SHALL BE TESTED TO MEET OR EXCEED THE REQUIREMENTS OF THE UL 9A STANDARD. ALL MATERIALS SHALL BE TESTED TO MEET OR EXCEED THE REQUIREMENTS OF THE UL 9A STANDARD.



Corporate Headquarters
5134 Burr Road, Chicago, IL 60630
Phone: 603-967-2553 Fax: 312-655-7875

Because Image Is Everything



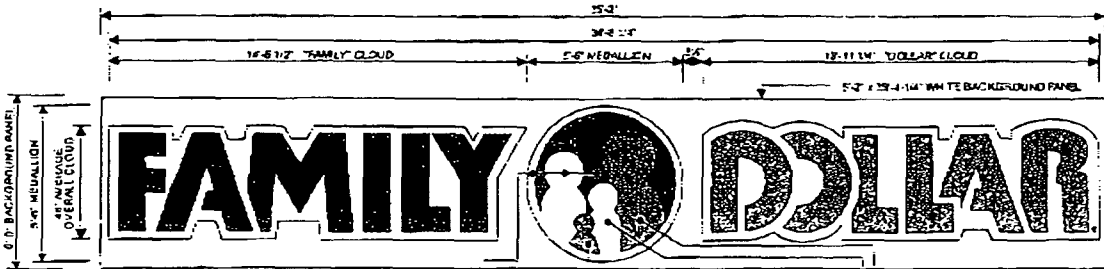

FRONT VIEW / LINEAR CLOUD-MEDALLION ELEVATION

NOTE: ALL WIRE PEGS IN WORD UNITS TO CENTERPE IN CABINETS HORIZONTALLY AND VERTICALLY

SCALE: 1/4\"/>

TOTAL SQ FT = 146.17

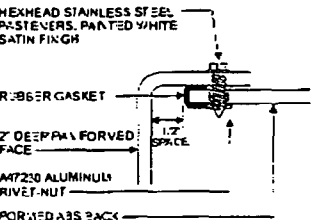

FACE MTG. DETAIL
SIDE ELEVATION - SCALE: 3/4\"/>

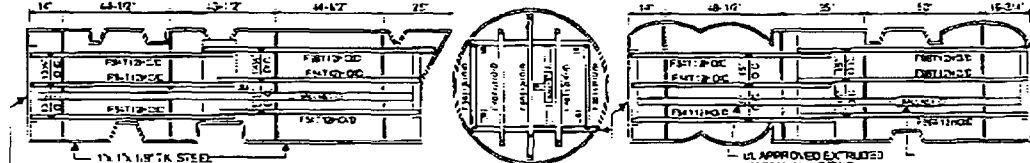

FRONT VIEW / INTERIOR DETAIL

SCALE: 3/4\"/>

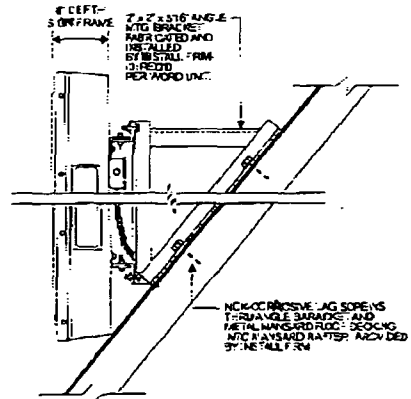

SECTION VIEW

GENERAL SPECIFICATIONS:
CLOUD FORMAT LOGO-MEDALLION AND WORD FORMS AS PER FINALIZED APPROVED DRAWINGS BASED ON THE 48\"/>

LOGO-MEDALLION: #157 UNIQUE RED (LAC/FL), #155 ORANGE (FAB) AND WHITE TRANSLUCENT FAMILY: #137 UNIQUE RED (LACRYL) COLOR: #155 ORANGE (FVS) SACKGROUND BORDER & PANEL: WHITE TRANSLUCENT #156 ORANGE (FMS) CNT: #165 ORANGE (FUS) RETURNS & BACKS: WHITE ALL CLOUD FORM VTG. SCRIP/H HEADS TO BE WHITE

FACE MATERIAL BURN RATE: UL 94 FLAM CLASS RATWO-BMV-2

SCALE BASED ON TABLOID SIZE PAPER

3.3 AMPS TOTAL UNDERWATER LABORATORIES ELECTRIC SIGN



Project Information

Client: Family Dollar
Location: 6190 S. Archer Ave., Chicago, IL

Project: F2023118 Chicago, IL, GUM Cloud Medallion Mtg

Date	By	Approved
10/07/10	Issue Date	MP

Date / Description

Client Review Status

Not Submitted Not Approved Approved (Pending) Approved (Final) Approved (Final) Approved (Final) Approved (Final) Approved (Final)

Notes

This is a copy of a prepared drawing created by Allen Industries, Inc. It is intended for use in the construction of the project and is not to be used for any other purpose. All rights reserved. All in part of this drawing is the property of Allen Industries, Inc.

Allen Industries
Corporate Identity Programs

Corporate Headquarters
5454 Burnt Paper Road, Greensboro, NC 27409
Phone 800-957-2563 Fax 336-668-7875

Because Image Is Everything

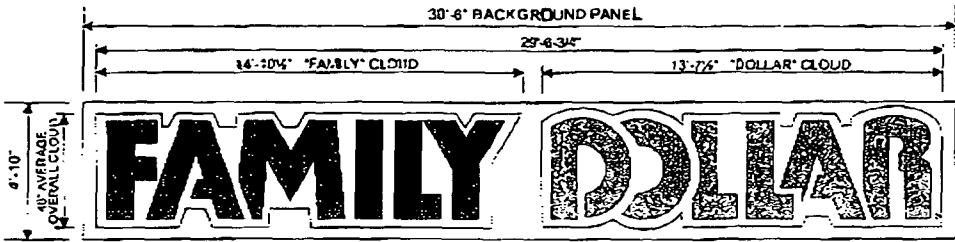

OVERALL SQ. FT. = 117.00

GENERAL SPECIFICATIONS:

CLOUD FORMAT LOGO LETTERING AND MCHD FORMS AS PER FINALIZED APPROVED DRAWINGS BASED ON THE 48" CLOUDS
 ILLUSTRATED. CLOUD FORMAT SHALL ENCOMPASS THE FAMILY DOLLAR STANDARD LOGO FORMS ALLOWING THE USE OF T-
 12 HOUR FLUORESCENT LAMPING SYSTEM (NO LAMP SOCKETS, WIRE TRAYS AND ELECTROMIC BALLASTS U.L. APPROVED.
 CLOUD SIGNS SHALL BE ASSEMBLED WITH 22G THICK ABS BACKS AND RETURNS FACE SHALL BE FORMED 177 THICK SOLAR
 GRADE POLYCARBONATE, WITH ALL COLORS APPLIED SECOND SURFACE. FACE IS HELD WITH FASTENERS THROUGH THE
 INTEGRAL MOLDED LIP.
 CLOUD SIGN UNITS ATTACHED TO ALUMINUM BACKGROUND PANEL WITH 1/2" DIA. S.S. THRU BOLTS.

COLORS:

LOCO MECH ON - #157 LAMBE RED (LACRYL)
 FAMILY - #131 UNIDIE RED (LACRYL)
 DOLLAR - #155 ORANGE (PU)
 BACKGROUND BORDER & FLANGE - WHITE TRANSLUCENT
 T-12 DRAAGE (PU)
 RETURNS A BACKS - WHITE
 ALL CLOUD FACE MFG. SCREW HEADS TO BE WHITE

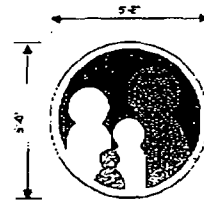

TOTAL SQ. FT. = 17.27

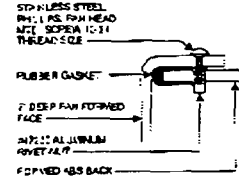

FACE MOUNTING DETAIL

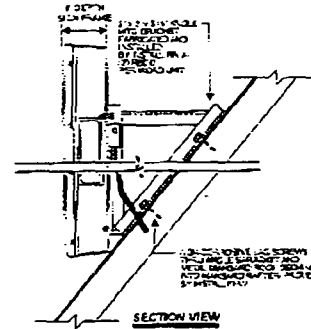

Project Information

Client
 Family Dollar
Location
 2190 S. Archer Ave.
 Chicago, IL
Project Name
 Family Dollar - Chicago IL - Sign Clouds - Sign Board L.R. Side

Discipline	Design	Project Manager
House	SC	MP

Date / Description

Date	Issue Description
10/28/10	Issue Date

Client Review Status

For Review, To Proceed with "Approved" Check the box to show that the client has reviewed and approved the design.
 Approved Approved as Modified Review & Resubmit
 Other _____

Notes

If you are not a sign company, please contact your local sign dealer for more information. This document is for your review only. It is not to be used for production. The sign dealer is responsible for the final production of the sign. For more information, contact your local sign dealer.



BUILDING ELEVATION
 SCALE: NTS

FACE MATERIAL BURN RATE:
 UL 94 FLAM CLASS RATING-8MV-2

SCALE BASED ON TABLOID SIZE PAPER

2.2 AMPS TOTAL

 UL FIREWEIGHTED
 LABORATORIES
 E-223
 ELECTRICAL SIGN





D/F SIGN ELEVATION
SCALE = 3/8" = 1'-0"

OVERALL SQ. FT. = 29.94
FACE MATERIAL BURN RATE:
UL S4 FLAM CLASS RATING: 94V-2

GENERAL SPECIFICATIONS:

- Sign Cabinet: 4'-1" x 7'-4" (12" deep) double face aluminum sign cabinet manufactured from 12" deep aluminum cabinet extrusion & 2" aluminum retainer extrusion, standard Allen Ind. extrusions
- Illumination: (6) F48T12-010 Fluorescent lamps powered by electronic ballast as required. Disconnect switch will be located at lower end side of cabinet
- Sign Face: (2) each formed 2" deep, 177" thick polycarbonate faces with 3/8" embossed "FAMILY DOLLAR" copy and 1/4" embossed copy letter. Registered mark to be flat (1) one side of face and fixed with 2" retainer system and Ninged for sanding
- Sign Colors: Cabinet & Retainer = #02#8 UNIQUE RED (CRIP-GUARD)
Face Colors: #437 UMQUE RED (LACRYL), #166 CRANKE (PMS), WHITE
- Installation: Sign to be installed on existing steel tube support

NOTE All components are U.L. listed with U.L. Label.

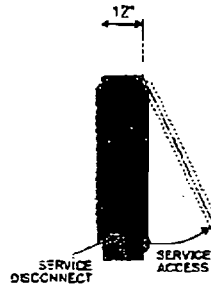

END VIEW
SCALE = 3/8" = 1'-0"

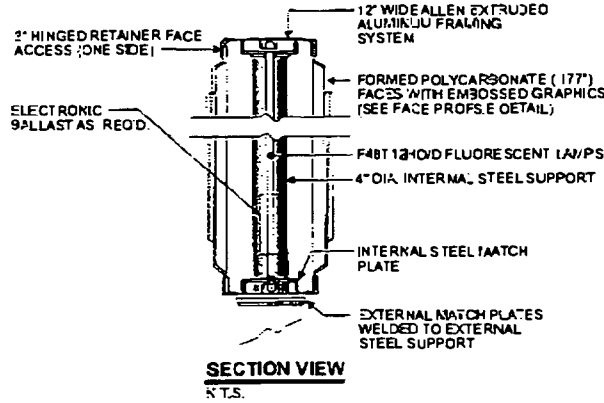

SECTION VIEW
N.T.S.

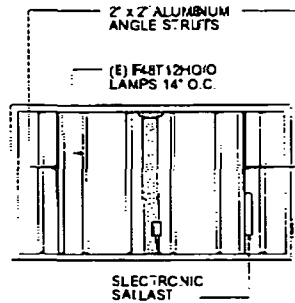

LAMPING DETAIL VIEW
SCALE: N.T.S.

NOTE: RAINT POLE & READER/CARD CABINET WHITE

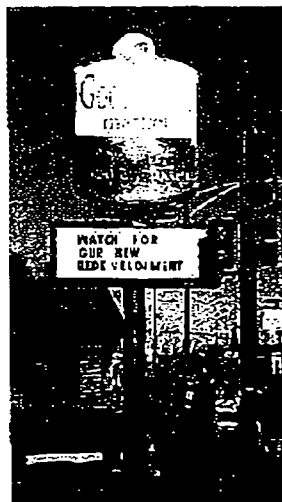

SCALE BASED ON TABLOID SIZE PAPER



Project Information

Client: Family Dollar
Location: 6196 S Archer Ave. Chicago, IL
File: D-3518 Chicago E. 4-1x7-4 Cabinet
Date: House SC Project Name: MLP

Date / Description

10/06/10 Issue Date

Client Review Status

Client Review Status: Approved Pending Rejected
 Approved Approved as Noted Revised & Resubmit

Notes

This sign is the property of Allen Industries, Inc. and is not to be used in any other location without the written consent of Allen Industries, Inc. All rights reserved. No part of this document may be reproduced or transmitted in any form or by any means, electronic or mechanical, including photocopying, recording, or by any information storage and retrieval system, without the prior written permission of Allen Industries, Inc.



Corporate Headquarters
3434 Burnt Pine Rd., Oceanside, NC 27513
Phone: 800-387-2553 Fax: 336-686-7875

Because Image Is Everything™