



City of Chicago



Or2020-317

Office of the City Clerk

Document Tracking Sheet

Meeting Date:	11/16/2020
Sponsor(s):	Napolitano (41)
Type:	Order
Title:	Issuance of permits for sign(s)/signboard(s) at 8725-8745 W Higgins Rd - 204 sq. ft.
Committee(s) Assignment:	Committee on Zoning, Landmarks and Building Standards

CITY COUNCIL
COMMITTEE ON ZONING, LANDMARKS AND BUILDING STANDARDS

COUNCIL ORDER

RE: Approval of sign over 100 square feet in area or over 24 feet above grade

ORDERED, that the City Council hereby approves the following sign application submitted by:

Applicant: Jones Lang LaSalle

(* The Applicant is the owner of the real property or the business tenant of the real property. Do not list the sign contractor, sign erector, sign company or advertising entity in the above space.)

This Order approves the following sign in accordance with Municipal Code of Chicago Section 13-20-680:

Address of Sign: 8725-45 W Higgins Rd Chicago, IL 60631

Zoning District: PD 340

DOB Sign Permit Application #: _____

Sign Details:

1. On-premise OR Off-premise _____

2. Static sign OR Dynamic-image display sign _____

3. Number of sign faces 1

4. Projecting over the public way No (Yes or No) If yes, Public Way Use #: _____

5. Dimensions: Length 39 feet 0 inches Height 5 feet 3 inches

Total square feet in area: 204 feet _____ inches

6. Height above grade: 8 feet 0 inches

7. Elevation (side of building or lot where the sign will be erected): North

8. Name of Sign Contractor/Erector: Parvin-Clauss Sign Co

To be legal, such sign shall comply with all provisions of Title 17 of the Chicago Municipal Code ("Zoning Ordinance") and all other provisions of the Municipal Code governing the permitting, construction and maintenance and removal of signs and sign structures. Failure of the applicant and the applicant's successors to comply shall be grounds for invalidation or revocation of the sign permit.

Alderman

41
Ward

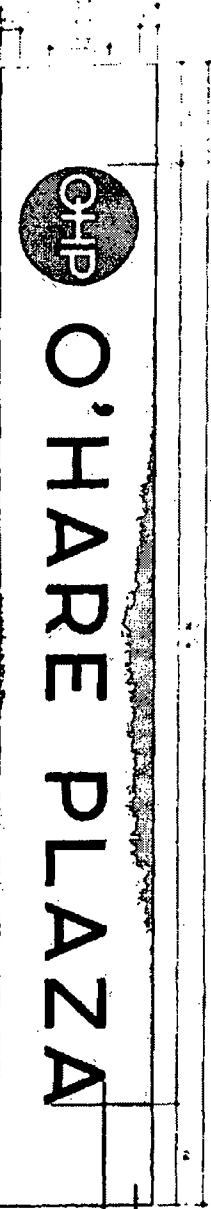

SIGN FACE ELEVATION
Scale: 1/4" = 1'-0"

SPECIFICATIONS

- 1 Sign Cabinet:
Fabricated aluminum frame construction w/ 1/8" slat -
mounted face internally aluminum
Panel #1 - all surfaces.
- 2 Sign Graphics:
Logo: 3/4" tall white acrylic paint-thru graphic w/ Avery 800-427 (PMS 200)
Fabrication: Vinyl w/ Rembrandt Dye White Copy
Shape: Precision White LED Modules - fixed / Halo Dimension
Logo/Type: 3/4" tall white acrylic paint-thru w/ 3M 3635-222 Dual Color Bond Vinyl
Attention: Stormlight 8000 LEDs
- 3 Remnant Material:
Fabricated aluminum mounted to Structural Angle Mount w/
counter-sinks / fasteners in metal
Panel #2
- 4 LED Strip Lights:
Astron LED Flex Mounted into metal
bracketed into front by / Mount Rail

SIGN SIDE ELEVATION
Scale: 1/4" = 1'-0"

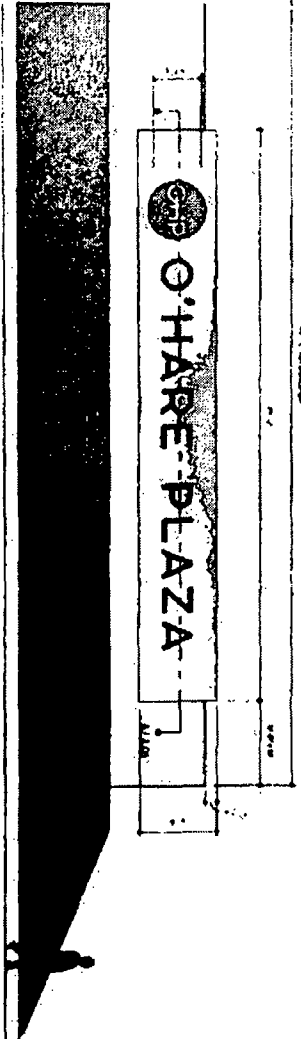
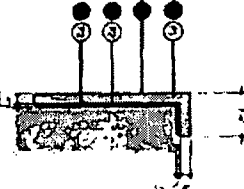

ELEVATION - WALL SIGN
Scale: 1/8" = 1'-0"

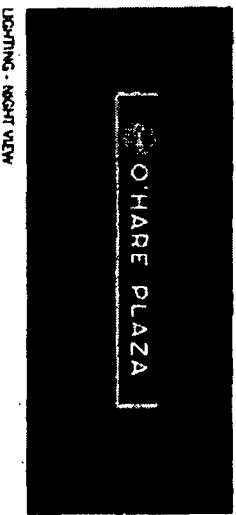

LIGHTING - NIGHT VIEW

This drawing is intended to be used for information only. It is not intended to be used for construction. The contractor is responsible for obtaining all necessary permits and for ensuring that the sign meets all applicable codes and regulations. The sign is the property of Parvin-Clauss Sign Company. All rights reserved. © Parvin-Clauss Sign Company, 2019.

© Copyright 2019 by Parvin-Clauss Sign Co.

Parvin-Clauss
SIGN COMPANY

PROJECT:
O'HARE PLAZA
6725-45th Higgins Road
Chicago, IL

CUSTOMER APPROVAL:
DATE:

AUTHORIZED SIGNATURE:

ORGANIZATION:
L&S SIGNAGE / ILS
DRAWN BY: SA Markov
DATE: 9-24-19
SCALE: 1/4" = 1'

SHEET NO.: 5 of 11
WORK ORDER / B/L / JOB: 82957 / 5628
FILE NUMBER: QLD82957

REVISIONS:

1	10-23-19	AKA
2	11-04-19	per client review
3	9-10-20	new colors & logo
4	9-11-20	details
5	10-01-20	logo color

This sign is intended to be installed in accordance with the requirements of the National Electrical Code and other applicable local codes. The client's project number and building of the sign.

39'-0" SIGN

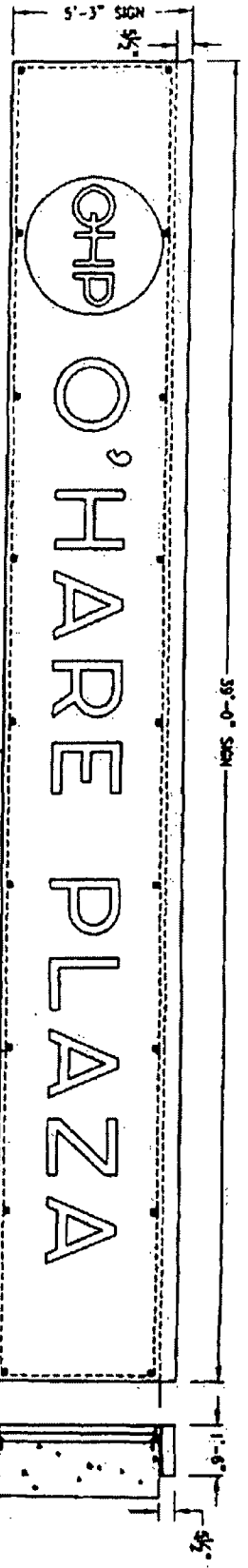

ELEVATION VIEW

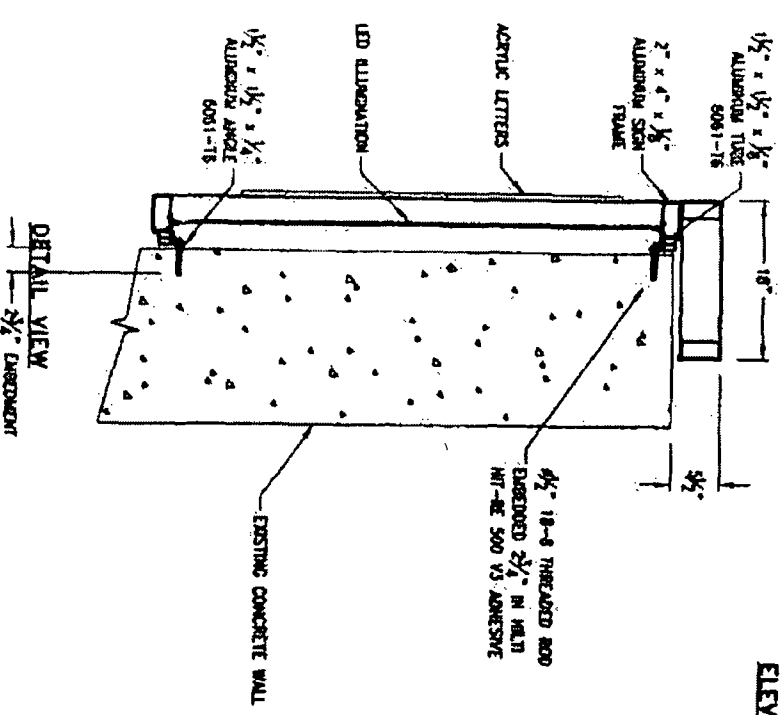

DETAIL VIEW

DESIGN WIND LOAD: 30.0 PSF
Based on the Chicago Building Code 16 (15-52-310) (i) 1a
for wind signs.

DESIGN SNOW LOAD: 25.0 PSF
Based on the Chicago Building Code 16 (15-52-280) (a)
for flat roofs.

NOTE:
All checked to be in accordance
with UL, the NEC and local code.

Parvin-Claus
SIGN COMPANY

1840 S. MICHIGAN AVE. CHICAGO, IL 60605
TEL: 312.467.1111 FAX: 312.467.1112
WWW.PARVINCLAUS.COM

PROJECT:

OHARE PLAZA
8725-45 W Higgins Road
Chicago, IL

CUSTOMER APPROVAL:

DATE: _____
AUTHORIZED SIGNATURE: _____

REPRESENTATIVE:

NAME: Lisa Staszak / LLS
DATE: 9/24/19

SCALE:

SCALE: NTS
SHEET NO.: 7 of 11

WORK ORDER / ELECTION:

WORK ORDER / ELECTION: B20571/5626
JOB NUMBER: OXD2857

REVISIONS:

1	10/30/19 - New Signage
2	11/04/19 - per client review
3	11/12/19 - Add engineering
4	9/10/20 - new colors & logo
5	
6	
7	

This sign is intended to be installed in accordance with the requirements of the National Fire Protection Association (NFPA) 701, Chapter 10, Section 10.10.1. The sign shall be installed in accordance with the requirements of the National Fire Protection Association (NFPA) 701, Chapter 10, Section 10.10.1. The sign shall be installed in accordance with the requirements of the National Fire Protection Association (NFPA) 701, Chapter 10, Section 10.10.1.