



# City of Chicago



Or2020-76

Office of the City Clerk

## Document Tracking Sheet

**Meeting Date:** 2/19/2020

**Sponsor(s):** Thompson (11)

**Type:** Order

**Title:** Issuance of permits for sign(s)/signboard(s) at 2201 S  
Halsted St - Permit No. 100860237

**Committee(s) Assignment:** Committee on Zoning, Landmarks and Building Standards

CITY COUNCIL  
COMMITTEE ON ZONING, LANDMARKS AND BUILDING STANDARDS

COUNCIL ORDER

RE: Approval of sign over 100 square feet in area or over 24 feet above grade

ORDERED, that the City Council hereby approves the following sign application submitted by:

Applicant\*: THE CANNERY ON HALSTED

(\* The Applicant is the owner of the real property or the business tenant of the real property. Do not list the sign contractor, sign erector, sign company or advertising entity in the above space.)

This Order approves the following sign in accordance with Municipal Code of Chicago Section 13-20-680:

Address of Sign: 2201 S. HALSTED STREET Chicago, IL 60608

Zoning District: PMD-11

DOB Sign Permit Application #: 100860237

Sign Details:

1. On-premise  OR Off-premise
2. Static sign  OR Dynamic-image display sign
3. Number of sign faces 1
4. Projecting over the public way YES (Yes or No) If yes, Public Way Use #: 1143863
5. Dimensions: Length 44 feet 0 inches Height 10 feet 0 inches  
Total square feet in area: 440 feet 0 inches
6. Height above grade: 59 feet 0 inches
7. Elevation (side of building or lot where the sign will be erected): NORTH
8. Name of Sign Contractor/Erector: LEGACY SIGN GROUP, LLC

To be legal, such sign shall comply with all provisions of Title 17 of the Chicago Municipal Code ("Zoning Ordinance") and all other provisions of the Municipal Code governing the permitting, construction and maintenance and removal of signs and sign structures. Failure of the applicant and the applicant's successors to comply shall be grounds for invalidation or revocation of the sign permit.

  
Alderman

11  
Ward

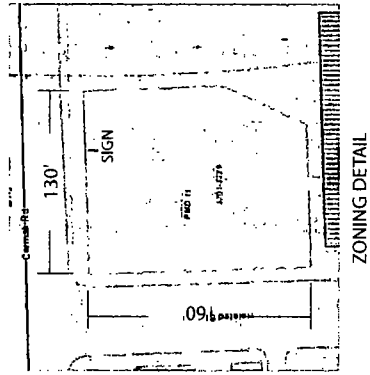
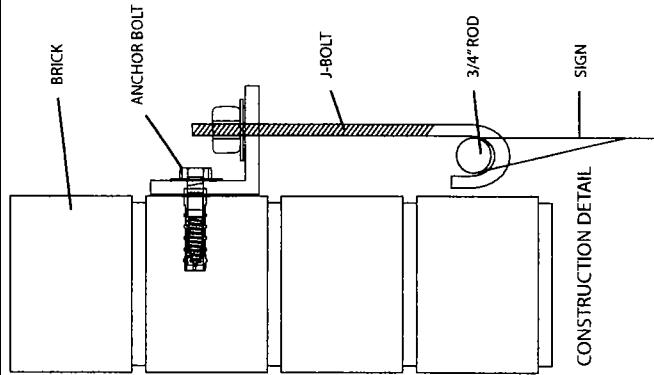

SIGN SPECS	
Sign Type:	NON-ILLUMINATED SIGN
Overall Size:	10'X44'
Square Footage:	440 sq ft.
Approximate weight:	120 lbs
Volt / Ampere Load:	N/A
Branch Circuits Required:	N/A
Lamp Type (Qty):	N/A
Power Supplies:	N/A

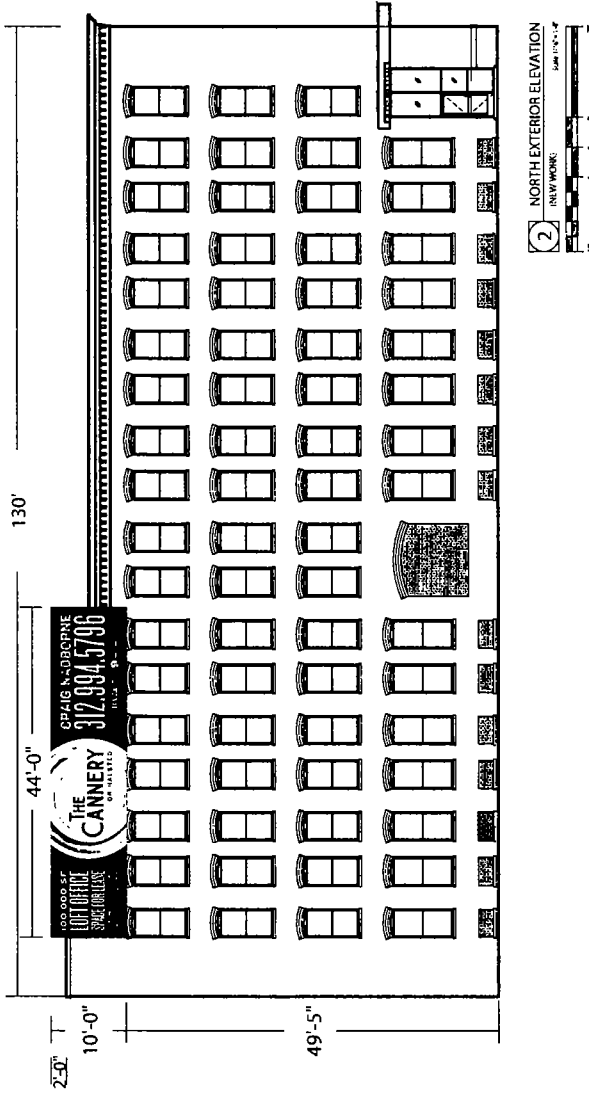

**LEGACY SIGN GROUP**  
 316 N 325 East, Valparaiso, IN 46388

PROJECT: The Cannery  
 2201 S. Halsted  
 Chicago, IL  
 REP: Shaun O'Brien 219-406-0218

DATE: 12-19-2019  
 DRAWING #: SO-0079-1  
 DESIGNER: Shaun O'Brien

REVISIONS:  
 1. REV 1-6-20  
 2. REV 1-28-20

CLIENT APPROVAL:  
 By signing this permit, I understand that I am accepting all aspects of this drawing. This includes artwork, specifications, dimensions, spelling, and all other representations herein. I also understand that color representations on this permit are approximate, and may not match actual colors produced.