



City of Chicago



O2016-5511

Office of the City Clerk

Document Tracking Sheet

Meeting Date:	7/14/2016
Sponsor(s):	Waguespack (32)
Type:	Ordinance
Title:	Grant(s) of privilege in public way for Mattress Firm - sign
Committee(s) Assignment:	Committee on Transportation and Public Way

ORDINANCE
MATTRESS FIRM
Acct. No. 393595 - 48
Permit No. 1123504

Be It Ordained by the City Council of the City of Chicago:

SECTION 1. Permission and authority are hereby given and granted to MATTRESS FIRM, upon the terms and subject to the conditions of this ordinance to maintain and use three (3) sign(s) projecting over the public right-of-way attached to its premises known as 3169 N. Lincoln Ave..

Said sign structure(s) measures as follows; along N. Lincoln:
Three (3) at eighteen point eight three (18.83) feet in length, one point eight three (1.83) feet in height and ten (10) feet above grade level.

The location of said privilege shall be as shown on prints kept on file with the Department of Business Affairs and Consumer Protection and the Office of the City Clerk.

Said privilege shall be constructed in accordance with plans and specifications approved by the Department of Transportation (Division of Project Development) and Zoning Department - Signs.

This grant of privilege in the public way shall be subject to the provisions of Section 10-28-015 and all other required provisions of the Municipal Code of Chicago.

The grantee shall pay to the City of Chicago as compensation for the privilege #1123504 herein granted the sum of nine hundred (\$900.00) per annum in advance.

A 25% penalty will be added for payments received after due date.

The permit holder agrees to hold the City of Chicago harmless for any damage, relocation or replacement costs associated with damage, relocation or removal of private property caused by the City performing work in the public way.

Authority herein given and granted for a period of five (5) years from and after Date of Passage.

Alderman _____

Scott Waguespack 32nd Ward

SIGN C 22 Mattress Firm Linear
Sign Type: Channel Letters on a Raceway w/ a Backer Panel
Illumination: Internally Illuminated LED
Square Footage: 34.53
To Grade: Top of Sign To Grade = 12.2
 Bottom of Sign To Grade = 10.4

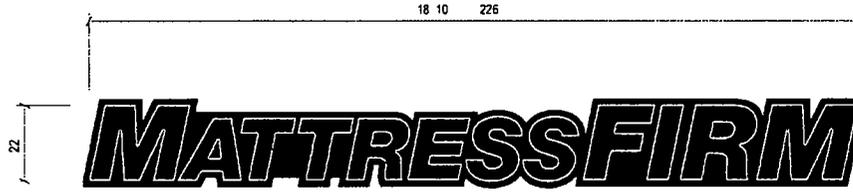

Sign Layout Detail
 Scale 3/8" = 1'-0"

Electrical Detail:
 P LED White LEDs
 (2) 50w Transformers @ 1.2 amps each
 Total Amps 2.40
 (1) 20 amp 120V Circuit Req



General Notes:
 This sign is to be installed in accordance with the requirements of Article 600 of the National Electrical Code
 1) Grounded and bonded per NEC 600.7/NEC 250
 2) Existing branch circuit in compliance with NEC 600.5 not to exceed 20 amps
 3) Sign is to be UL listed per NEC 600.3
 4) UL disconnect switch per NEC 600.6 required per sign component before leaving manufacturer
 For multiple signs a disconnect is permitted but not required for each section

Specifications: Channel Letters/ Backer Panel / Raceway
 1 Existing Facade Brick
 2 0.040 Aluminum letter returns painted to match black
 3 Jewelrite trimcap (black) bonded to face and #8 pan head screws to returns
 4 3mm Signabond Lite composite backs fastened to returns w/ 1/2" 18 gauge staples Seal w/ VOC compliant 360 white latex caulk to prevent moisture penetration (interior of sign can painted white for maximum illumination)
 5 White LEDs
 6 3/16 Acrylic faces
 7 R&H #2793 Red Acrylic for letters
 8 Disconnect switch UL Outdoor rated toggle type w/ neoprene boot per NEC 600-6
 9 Primary electrical feed in UL conduit / customer supplied UL junction box
 10 Transformers
 11 0.080 Aluminum raceway painted to match the facade
 12 15 x 2 x 0.1875 Aluminum mounting tabs welded to raceway
 Maximum 6" from each end and every 48" o.c.
 13 #12 x 1" TEC screws with 1 1/4" fender washers
 14 Mounting hardware 3/8" sleeve anchors
 15 0.080 Backer panel painted to match black

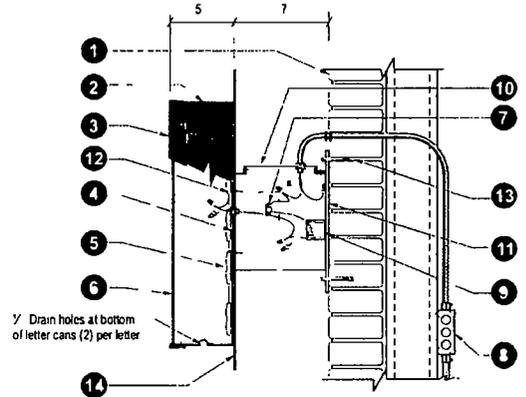

Section @ LED Channel Ltr/ Backer Raceway (Center)
 Scale N.T.S.



Client: Mattress Firm
 Site #: MF 119217
 Address: 3169 North Lincoln Ave
 Chicago IL 60657
 Lakeview West

REVISION	DATE	DESCRIPTION	BY
02/18/2016	Original Rendering	JH	
02/29/2016	Removing Awning	JL	
05/18/2016	Added Awning	JEH	

In rendering the property of Anchor Sign Inc. is the exclusive property of Anchor Sign Inc. and it is hereby stated that the design of this sign is the intellectual property of Anchor Sign Inc. and it is hereby stated that the design of this sign is the intellectual property of Anchor Sign Inc. and it is hereby stated that the design of this sign is the intellectual property of Anchor Sign Inc.

