



# City of Chicago



Or2016-85

Office of the City Clerk

## Document Tracking Sheet

<b>Meeting Date:</b>	2/10/2016
<b>Sponsor(s):</b>	Thompson (11)
<b>Type:</b>	Order
<b>Title:</b>	Issuance of permits for sign(s)/signboard(s) at 2601 S LaSalle St
<b>Committee(s) Assignment:</b>	Committee on Zoning, Landmarks and Building Standards

CITY COUNCIL MEETING

INTRODUCED FEBRUARY 10, 2016

**Ordered,** That the commissioner of buildings is hereby authorized and directed to issue

A sign permit to :                   **Landmark Sign Group**  
  **7424 Industrial Ave.**  
  **Chesterton, IN 46304**

For the erection of a sign/signboard over 24 feet in height and over 100 square feet .

(in area of one face) at:       **U-Haul Moving & Storage**  
  **2601 S. LaSalle St.**  
  **Chicago, IL 60616**

Dimensions: Length **34'1"**   Height **11'0"**

Height above grade/roof to top of sign **49'-0"**

Total Square Foot Area **375'0"**

Elevation   Southeast

To be legal, such sign(s) must comply with all applicable provisions of TITLE 17 to the Chicago Zoning Ordinance and all other applicable provisions of the Municipal Code of the City of Chicago governing the construction and maintenance of outdoor signs, signboards, and Structures.



Patrick D. Thompson  
Alderman, 11<sup>th</sup> Ward

**Permit # 100626829**





REV. 1 DIMENSIONS DATE APPROVED

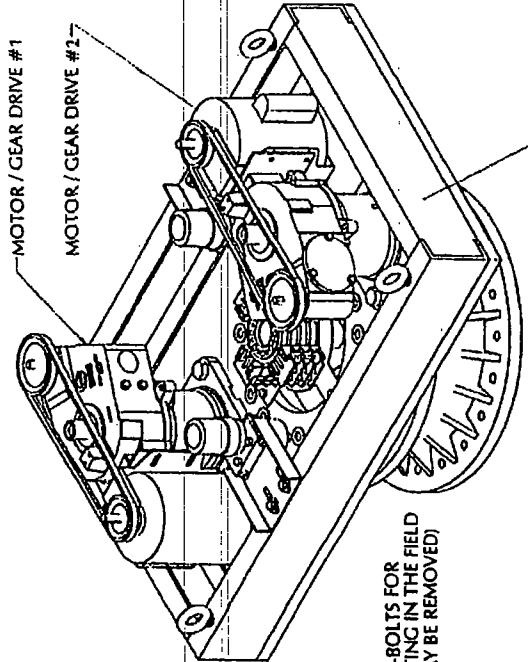
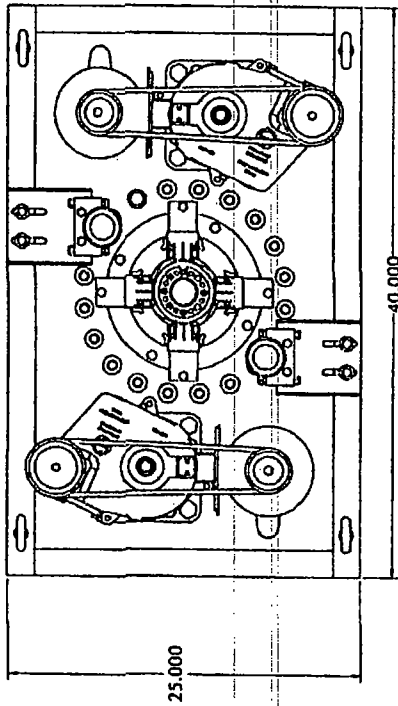

STRUCTURAL "C" CHANNEL: 5" X 9 LB/FT FOR CONNECTION TO SIGN STRUCTURE

EYE-BOLTS FOR LIFTING IN THE FIELD (MAY BE REMOVED)

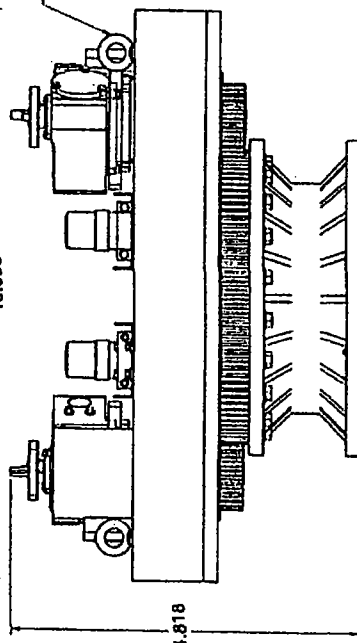

Ø 18.875 BOLT CIRCLE

DRIVE GEAR #2

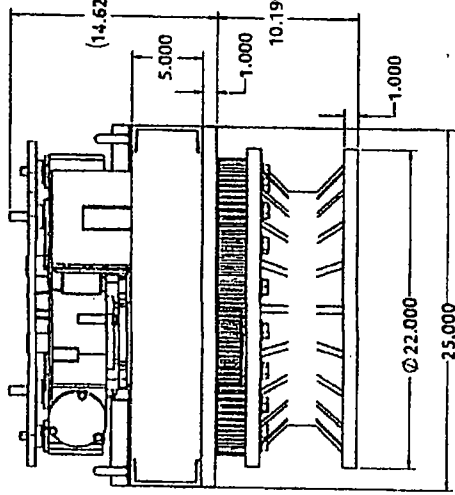
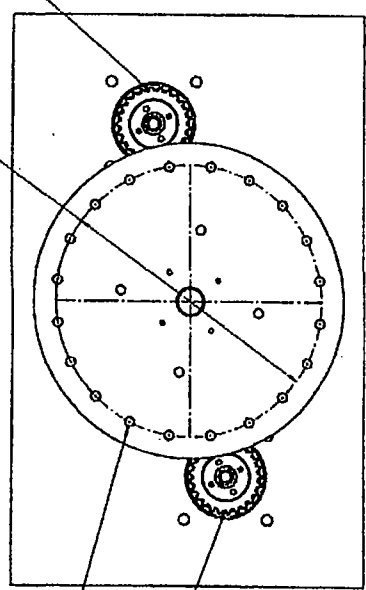

**DYNAPAC MODEL M-550G**  
HEAVY DUTY ROTATOR UNIT

- COMPRESSIVE WEIGHT CAPACITY = 50,000 LBS
- MAX. BENDING CAPACITY = 70,000 FT-LBS
- MAX. TORQUE OUTPUT = 2400 FT-LBS
- MAX. SHEAR CAPACITY = 30,000 LBF

M-550G  
DYNAPAC ROTATING CO.  
SALT LAKE CITY, UTAH

REV. 10/82  
D 146024 623

LICENSED STRUCTURAL ENGINEER  
GERALD R. CARSTENS  
81-3858  
STATE OF ILLINOIS