



City of Chicago



O2016-6272

Office of the City Clerk

Document Tracking Sheet

Meeting Date:	9/8/2016
Sponsor(s):	Smith (43)
Type:	Ordinance
Title:	Grant(s) of privilege in public way for Monica + Andy
Committee(s) Assignment:	Committee on Transportation and Public Way

Direct Introduction
43

ORDINANCE
MONICA + ANDY
Acct. No. 403707 - 1
Permit No. 1123323

Be It Ordained by the City Council of the City of Chicago:

SECTION 1. Permission and authority are hereby given and granted to MONICA + ANDY, upon the terms and subject to the conditions of this ordinance to maintain and use one (1) sign(s) projecting over the public right-of-way attached to its premises known as 2038 N. Halsted St..

Said sign structure(s) measures as follows; along N. Halsted Avenue:

One (1) at two point five (2.5) feet in length, two point five (2.5) feet in height and nine point two five (9.25) feet above grade level.

The location of said privilege shall be as shown on prints kept on file with the Department of Business Affairs and Consumer Protection and the Office of the City Clerk.

Said privilege shall be constructed in accordance with plans and specifications approved by the Department of Transportation (Division of Project Development) and Zoning Department - Signs.

This grant of privilege in the public way shall be subject to the provisions of Section 10-28-015 and all other required provisions of the Municipal Code of Chicago.

The grantee shall pay to the City of Chicago as compensation for the privilege #1123323 herein granted the sum of one hundred (\$100.00) per annum in advance.

A 25% penalty will be added for payments received after due date.

The permit holder agrees to hold the City of Chicago harmless for any damage, relocation or replacement costs associated with damage, relocation or removal of private property caused by the City performing work in the public way.

Authority herein given and granted for a period of five (5) years from and after Date of Passage.

Alderman _____

Michele Smith 43rd Ward



2333 N Seeley Ave
Chicago IL 60647

Phone 773 930 4361
sam@rightwaysigns.com

PRINTED ON RECYCLED PAPER
SM 001

ALEX PERRY

REPRESENTATIVE

1/1/2016

DATE

MICHELE SMITH

CLIENT NAME

MONICA + ANDY

CLIENT NAME

2038 N HALSTED ST,
CHICAGO, IL 60614

JOB LOCATION

SAM MCMORRIS

DRAWN BY

NOTES

NO COPYING PERMITTED
OR
REPRODUCTION IN ANY MANNER
WITHOUT THE WRITTEN PERMISSION
OF
RIGHT WAY SIGNS
ALL RIGHTS RESERVED
© 2016

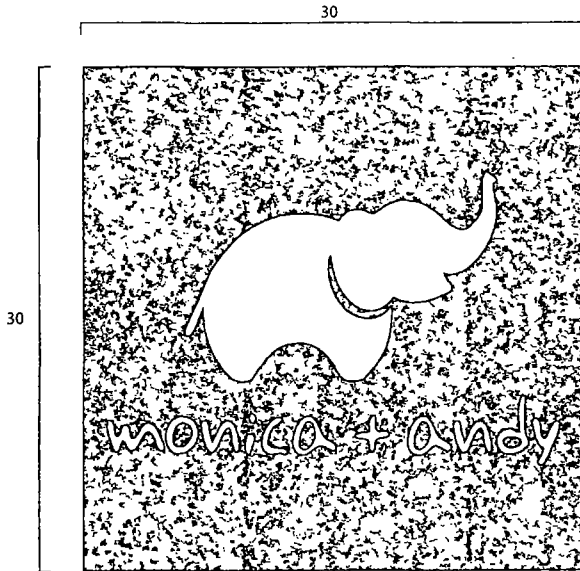

QTY (1) Double sided blade sign
Logo 1/2" thick white acrylic
Back 1/2" thick Aluminum painted PMS 429c
Sign weight 15 lbs

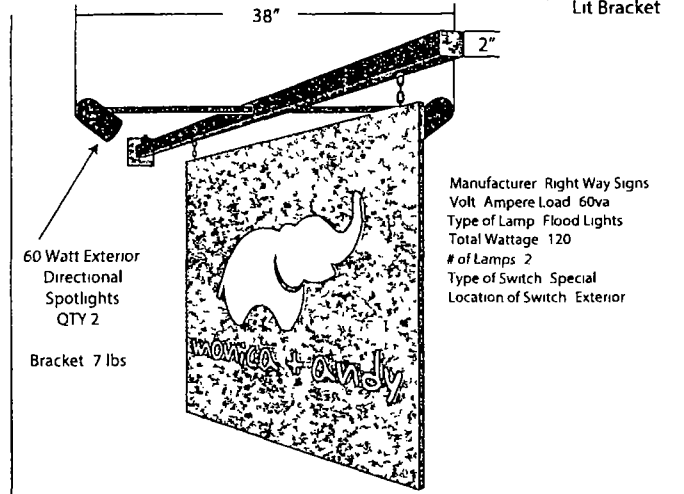

Manufacturer Right Way Signs
Volt Ampere Load 60va
Type of Lamp Flood Lights
Total Wattage 120
of Lamps 2
Type of Switch Special
Location of Switch Exterior

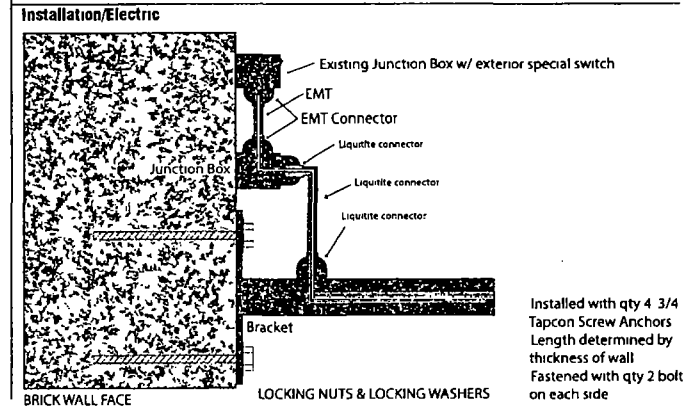

Installed with qty 4 3/4
Tapcon Screw Anchors
Length determined by
thickness of wall
Fastened with qty 2 bolts
on each side

By signing the Customer Acceptance on this print, I understand that I am accepting all aspects of this drawing. This includes artwork, specifications, dimensions, spelling, and all other representations herein. I also understand that color reproductions on this print are approximations and may not match manufacturer's samples exactly.

Customer Acceptance SIGNATURE _____ DATE _____ # REQUIRED Landlord Acceptance SIGNATURE _____ DATE _____ RWS INITIALS _____ DATE _____



07/20/2016

Alderman **Michele Smith**
Ward # 43
City of Chicago
City Hall, Room 300
121 North LaSalle Street
Chicago, Illinois 60602

Re: An ordinance to use and maintain a portion of the public right-of-way for **one (1) sign(s)** for **MONICA + ANDY**, adjacent to the premises known as **2038 N. Halsted St.**

Dear Alderman **Michele Smith**:

The applicant referenced above has requested the use of the public right-of-way for a **sign(s)**. An ordinance has been prepared by the Department of Business Affairs and Consumer Protection – Small Business Center - Public Way Use Unit for presentation to the City Council. Because this request was made for properties located in your ward, as approved by you as per the attached, I respectfully request that you introduce the attached ordinance at the next City Council meeting.

If you have any questions regarding this ordinance, please contact Anthony Bertuca at (312) 744-5506.

Department of Business Affairs and Consumer Protection