



City of Chicago



O2017-5863

Office of the City Clerk

Document Tracking Sheet

Meeting Date:	7/26/2017
Sponsor(s):	Smith (43)
Type:	Ordinance
Title:	Grant(s) of privilege in public way for La Colombe Torrefaction, Inc.
Committee(s) Assignment:	Committee on Transportation and Public Way

ORDINANCE
LA COLOMBE TORREFACTION, INC.
Acct. No. 359767 - 11
Permit No. 1128159

Be It Ordained by the City Council of the City of Chicago:

SECTION 1. Permission and authority are hereby given and granted to LA COLOMBE TORREFACTION, INC., upon the terms and subject to the conditions of this ordinance to maintain and use one (1) sign(s) projecting over the public right-of-way attached to its premises known as 858 W. Armitage Ave..

Said sign structure(s) measures as follows; along W Armitage Ave:
One (1) at six (6) feet in length, six (6) feet in height and nine (9) feet above grade level.

The location of said privilege shall be as shown on prints kept on file with the Department of Business Affairs and Consumer Protection and the Office of the City Clerk.

Said privilege shall be constructed in accordance with plans and specifications approved by the Department of Transportation (Division of Project Development) and Zoning Department - Signs.

This grant of privilege in the public way shall be subject to the provisions of Section 10-28-015 and all other required provisions of the Municipal Code of Chicago.

The grantee shall pay to the City of Chicago as compensation for the privilege #1128159 herein granted the sum of three hundred (\$300.00) per annum in advance.

A 25% penalty will be added for payments received after due date.

The permit holder agrees to hold the City of Chicago harmless for any damage, relocation or replacement costs associated with damage, relocation or removal of private property caused by the City performing work in the public way.

Authority herein given and granted for a period of five (5) years from and after Date of Passage.

Alderman 

Michele Smith 43rd Ward

SIGN A	Le Colombe Existing D/F Cabinet Sign
Type:	(2) new aluminum faces w/applied vinyl graphics & (2) new gooseneck lamps
Illumination:	Externally illuminated w/ new gooseneck lamps
Static Pressure:	36.30

Note
 New aluminum panels painted dark blue with white vinyl graphics. Existing cabinet and retainers to be painted blue to match face. Sign will be illuminated from above with new gooseneck style lamps.

Illumination to be controlled by an adjustable 24 hour timer

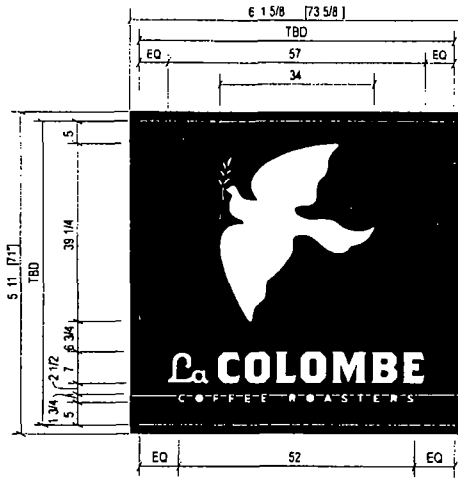

Sign Layout Detail

Scale 1/2" = 1' 0"

Specifications Existing D/F Cabinet Sign, w/ New Faces

- 1 Existing Facade Cabinet supports to brick building to remain repair if necessary
- 2 Existing sign cabinet to be painted to match 2767C
- 3 Existing retainers to be painted to match 2767C
- 4 (2) new 125 aluminum faces painted to match 2767C Blue with applied white vinyl graphics
- 5 2 New goose neck lamps clamped to existing pole

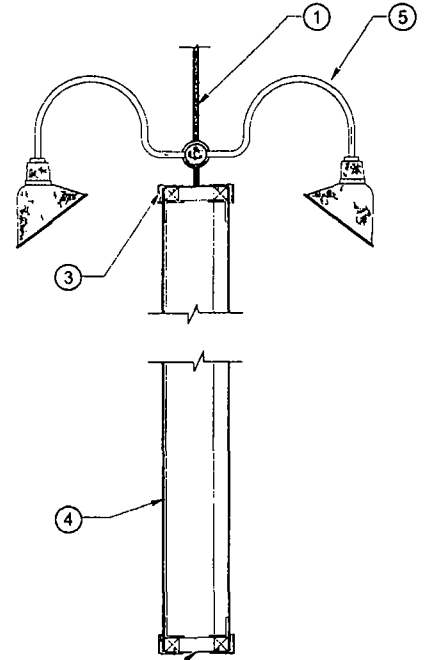

Section @ D/F Cabinet Sign

Scale NTS



La Colombe
 858 W Armitage Avenue
 Chicago IL 60614

Project ID# 111955
 Project Mgr Rob Young
 Designer Mike DeMarco
 Created on 03/01/2017

REVISIONS	R1_03/03/17_MD	Added note to sign A
	R2_03/07/17_MD	Updated sign specs/ chart
	R3_03/29/17_EH	Revised sign to have printed graphics instead of raised copy
	R4_05/02/17_KF	Removed Registered Trademark from logo on all pages