



City of Chicago



O2016-7417

Office of the City Clerk

Document Tracking Sheet

Meeting Date: 10/5/2016

Sponsor(s): Harris (8)

Type: Ordinance

Title: Grant(s) of privilege in public way for Southeast Chicago Chamber of Commerce - trash container - 8650 S Stony Island Ave - Privilege No. 1112196

Committee(s) Assignment: Committee on Transportation and Public Way

ORDINANCE
SOUTHEAST CHICAGO CHAMBER OF COMMERCE
Acct. No. 384199 - 10
Permit No. 1112196

Be It Ordained by the City Council of the City of Chicago:

SECTION 1. Permission and authority are hereby given and granted to SOUTHEAST CHICAGO CHAMBER OF COMMERCE, upon the terms and subject to the conditions of this ordinance to construct, install, maintain and use one (1) Trash container(s) on the public right-of-way adjacent to its premises known as 8650 S. Stony Island Ave..

Said Trash container(s) at S. Stony Island Avenue measure(s):

One (1) at two point two five (2.25) feet in length, and two point two five (2.25) feet in width for a total of five point zero six (5.06) square feet. Said trash container is approximately forty-six (46) inches in height.

The location of said privilege shall be as shown on prints kept on file with the Department of Business Affairs and Consumer Protection and the Office of the City Clerk.

Said privilege shall be constructed in accordance with plans and specifications approved by the Department of Transportation (Division of Project Development).

This grant of privilege in the public way shall be subject to the provisions of Section 10-28-015 and all other required provisions of the Municipal Code of Chicago.

The grantee shall pay to the City of Chicago as compensation for the privilege #1112196 herein granted the sum of seventy-five (\$75.00) per annum in advance.

A 25% penalty will be added for payments received after due date.

The permit holder agrees to hold the City of Chicago harmless for any damage, relocation or replacement costs associated with damage, relocation or removal of private property caused by the City performing work in the public way.

Authority herein given and granted for a period of five (5) years from and after Date of Passage.

Alderman 

Michelle A. Harris 8th Ward

- ADA COMPLIANT FOR ACCESSIBILITY CONCERNS
- 64 GALLONS OF CAPACITY
- ADVERTISING PANELS CAN BE CHANGED IN SECONDS
- UNOBTUSIVE AND ATTRACTIVE STYLING
- DURABLE STEEL CONSTRUCTION
- CORROSION RESISTANT MATERIALS AND POWDER COATED FINISHES
- STANDARD AND CUSTOM COLORS

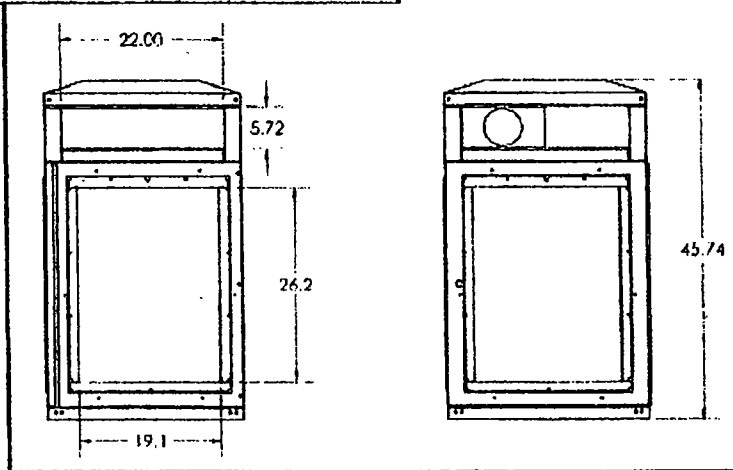
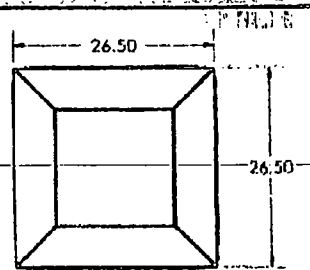

50

b. Includes side door entry, and the ability to provide customized advertising on 4 sides. Choice of color available. Standard colors at no additional charge, See standard color options below:

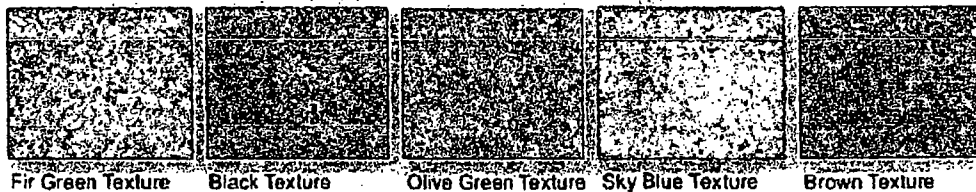

Custom Color Options available at an additional charge - see attached paint options for all options. Exact pricing for color depends on color choice.



10/5/2016

Alderman **Michelle A. Harris**
Ward # **08**
City of Chicago
City Hall, Room **300**
121 North LaSalle Street
Chicago, Illinois 60602

Re: An ordinance to use and maintain a portion of the public right-of-way for **one (1) trash container(s)** for **SOUTHEAST CHICAGO CHAMBER OF COMMERCE**, adjacent to the premises known as **8650 S. Stony Island Ave.**.

Dear Alderman **Michelle A. Harris**:

The applicant referenced above has requested the use of the public right-of-way for a **trash container(s)**. An ordinance has been prepared by the Department of Business Affairs and Consumer Protection – Small Business Center - Public Way Use Unit for presentation to the City Council. Because this request was made for properties located in your ward, as approved by you as per the attached, I respectfully request that you introduce the attached ordinance at the next City Council meeting.

If you have any questions regarding this ordinance, please contact Anthony Bertuca at (312) 744-5506.

Department of Business Affairs and Consumer Protection