



City of Chicago



O2017-4720

Office of the City Clerk

Document Tracking Sheet

Meeting Date:	6/22/2017
Sponsor(s):	Mell (33)
Type:	Ordinance
Title:	Grant(s) of privilege in public way for Metro PCS - sign - Privilege No. 1127872
Committee(s) Assignment:	Committee on Transportation and Public Way

ORDINANCE
METRO PCS
Acct. No. 413335 - 2
Permit No. 1127872

Be It Ordained by the City Council of the City of Chicago:

SECTION 1. Permission and authority are hereby given and granted to METRO PCS, upon the terms and subject to the conditions of this ordinance to maintain and use one (1) sign(s) projecting over the public right-of-way attached to its premises known as 3007 W. Irving Park Rd..

Said sign structure(s) measures as follows; along W Irving Park Rd:

One (1) at eleven (11) feet in length, one point one seven (1.17) feet in height and thirteen (13) feet above grade level.

The location of said privilege shall be as shown on prints kept on file with the Department of Business Affairs and Consumer Protection and the Office of the City Clerk.

Said privilege shall be constructed in accordance with plans and specifications approved by the Department of Transportation (Division of Project Development) and Zoning Department - Signs.

This grant of privilege in the public way shall be subject to the provisions of Section 10-28-015 and all other required provisions of the Municipal Code of Chicago.

The grantee shall pay to the City of Chicago as compensation for the privilege #1127872 herein granted the sum of one hundred (\$100.00) per annum in advance.

A 25% penalty will be added for payments received after due date.

The permit holder agrees to hold the City of Chicago harmless for any damage, relocation or replacement costs associated with damage, relocation or removal of private property caused by the City performing work in the public way.

Authority herein given and granted for a period of five (5) years from and after Date of Passage.

Alderman _____

Deborah Mell 33rd Ward

Front-Lit Channel Letters w/ LED Illumination • Raceway Mounted

Prepared Square Footage of this sign: 18.59 sq ft
 Lineal feet of store front: _____
 Actual Square Footage Allowed by village: _____



White Trimcap/ White Return

Approved Arlon Vinyl

Specifications: LED Channel Letters

- 1 Existing Facade Concrete Block/ Brick
- 2 0 040 Aluminum letter returns painted to match white
- 3 0 125 x 1 white Jewelite trimcap
- 4 040 White Aluminum backing
(interior of sign can will be white for maximum illumination)
- 5 Interone LED s
- 6 flexible conduit connectors
- 7 1/8 Acrylite #2283
- 8 LED transformer (Mean well)
- 9 waterproof disconnect switch per NEC 600 6
- 10 Aluminum Raceway to match fascia color
- 11 1/4 x 2 x 11 Aluminum Bracket
- 12 Liquid tight metallic conduit
(All penetration will be caulked w/ high grade silicone)
- 13 Mounting hardware to suit (Non Corrosive)

Electrical Detail: Channel Letters

Mean well CLG 60 12
 (1) 60w Transformers @ 0 80
 Total Amps 0 80
 (1) Minimum of 20 amp 120V Circuit Req

General Notes:

This sign is to be installed in accordance with the requirements of Article 600 of the National Electrical Code

- 1) Grounded and bonded per NEC 600 7/NEC 250
- 2) Existing branch circuit in compliance with NEC 600 5 not to exceed 20 amps
- 3) Sign is to be per NEC 600 3
- 4) disconnect switch per NEC 600 6 required per sign component before leaving manufacturer

*For multiple signs a disconnect is permitted but not required for each section

CHANNEL LETTER - TYPICAL SECTION - FRONT-LIT PLASTIC FACE

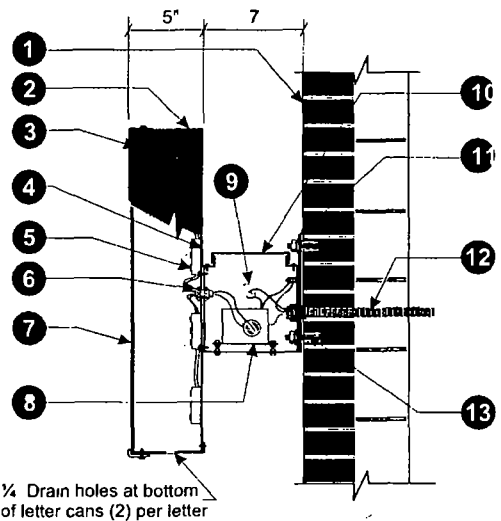

Section @ LED Channel Letter Raceway mount installation Scale N T S

ELECTRICAL NOTES
 Sign Company DOES NOT provide primary electrical to sign.
 Power to the sign must be done by a licensed electrical contractor or licensed electrician
 Each sign must have:
 1. A minimum of one dedicated 120V 20A circuit
 2. Junction box installed within 6 feet of sign
 3. Three wires Line, Ground, Neutral



5500 N. Kedzie Ave Chicago, IL 60625
 773-267-6007 | sales@tfasigns.com

Client Metro PCS
Address 3007 W Irving Park Rd
 Chicago IL 60618
Tel _____
Email _____

Landlord _____
Address _____
Tel _____
Email _____

Start Date 00/00/0000
Last Revision 00/00/0000
Job# 00000
Drawing# 00000a v1 s1 / e1
Page 1 of 2

Client Approval _____
Landlord Approval _____

Sales Rep Seung Park
Designer Vernon James
E322358



Department of Business Affairs and Consumer Protection
Small Business Center - Public Way Use Unit
City Hall - 121 N. LaSalle Street, Room 800 • Chicago, IL 60602
312-74-GOBIZ / 312-744-6249 • (312) 744-1944 (TTY)
<http://www.cityofchicago.org/bacp>

05/24/2017

Alderman **Deborah Mell**
Ward # 33
City of Chicago
City Hall, Room 200
121 North LaSalle Street
Chicago, Illinois 60602

Re: An ordinance to use and maintain a portion of the public right-of-way for **one (1) sign(s)** for **METRO PCS**, adjacent to the premises known as **3007 W. Irving Park Rd.**

Dear Alderman **Deborah Mell**:

The applicant referenced above has requested the use of the public right-of-way for a **sign(s)**. An ordinance has been prepared by the Department of Business Affairs and Consumer Protection – Small Business Center - Public Way Use Unit for presentation to the City Council. Because this request was made for properties located in your ward, as approved by you as per the attached, I respectfully request that you introduce the attached ordinance at the next City Council meeting.

If you have any questions regarding this ordinance, please contact Anthony Bertuca at (312) 744-5506.

Department of Business Affairs and Consumer Protection