



City of Chicago



O2019-7435

Office of the City Clerk

Document Tracking Sheet

Meeting Date:	9/18/2019
Sponsor(s):	Gardiner (45)
Type:	Ordinance
Title:	Canopy(s) for Mc Namara's Food & Drinks
Committee(s) Assignment:	Committee on Transportation and Public Way

ORDINANCE
MC NAMARA'S FOOD & DRINKS
Acct. No. 17090 - 1
Permit No. 1141957

Be It Ordained by the City Council of the City of Chicago:

SECTION 1. Permission and authority are hereby given and granted to MC NAMARA'S FOOD & DRINKS, upon the terms and subject to the conditions of this ordinance to maintain and use, as now constructed, two (2) Canopy(s) projecting over the public right-of-way adjacent to its premises known as 4328 W. Irving Park Rd..

Said Canopy(s) at W. Irving Park Road measure(s):

One (1) at fifty (50) feet in length, and three (3) feet in width for a total of one hundred fifty (150) square feet.

Said Canopy(s) at N. Lowell measure(s):

One (1) at fifteen (15) feet in length, and three (3) feet in width for a total of forty-five (45) square feet.

The location of said privilege shall be as shown on prints kept on file with the Department of Business Affairs and Consumer Protection and the Office of the City Clerk.

Said privilege shall be constructed in accordance with plans and specifications approved by the Zoning Department - Signs.

This grant of privilege in the public way shall be subject to the provisions of Section 10-28-015 and all other required provisions of the Municipal Code of Chicago.

The grantee shall pay to the City of Chicago as compensation for the privilege #1141957 herein granted the sum of one hundred twenty-five (\$125.00) per annum in advance.

A 25% penalty will be added for payments received after due date.

The permit holder agrees to hold the City of Chicago harmless for any damage, relocation or replacement costs associated with damage, relocation or removal of private property caused by the City performing work in the public way.

Authority herein given and granted for a period of five (5) years from and after 07/29/2019.

Alderman

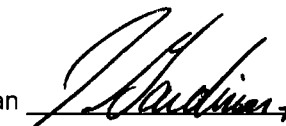

James Gardiner 45th Ward

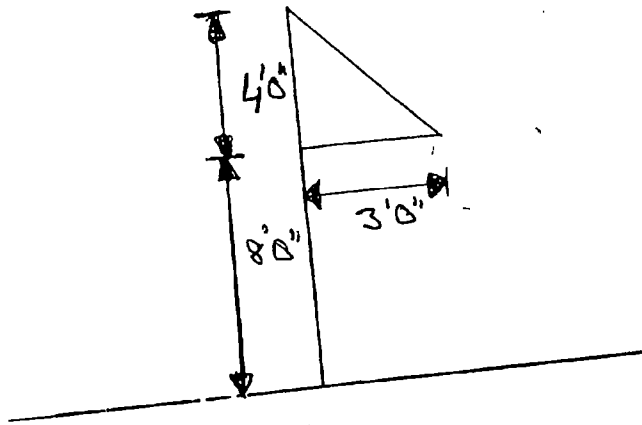
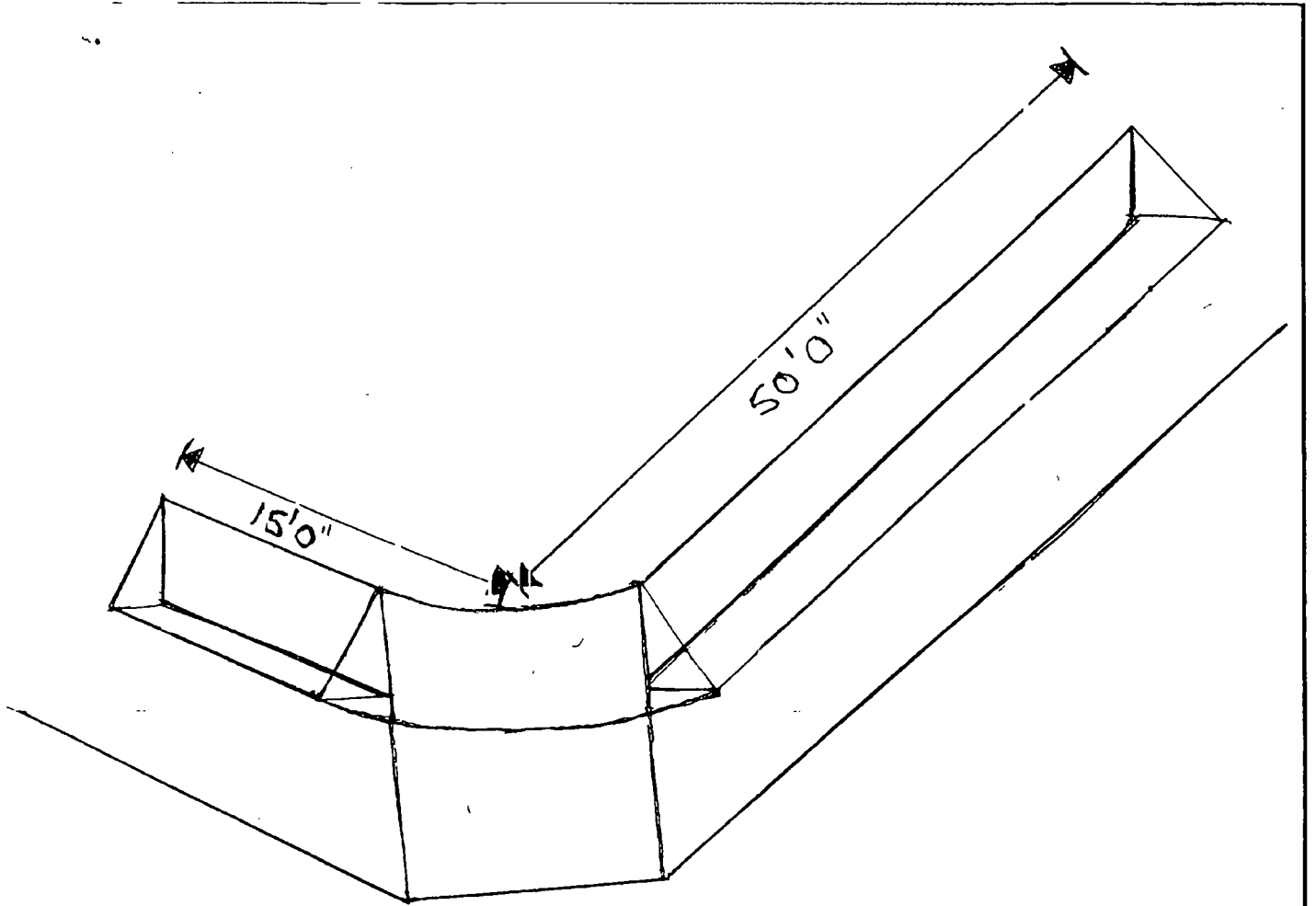



09/18/2019

Alderman James Gardiner
Ward # 45
City of Chicago
City Hall, Room 300
121 North LaSalle Street
Chicago, Illinois 60602

Re: An ordinance to use and maintain a portion of the public right-of-way for **two (2) canopy(ies)** for **MC NAMARA'S FOOD & DRINKS**, adjacent to the premises known as **4328 W. Irving Park Rd.**.

Dear Alderman **James Gardiner**:

The applicant referenced above has requested the use of the public right-of-way for a **canopy(ies)**. An ordinance has been prepared by the Department of Business Affairs and Consumer Protection – Small Business Center - Public Way Use Unit for presentation to the City Council. Because this request was made for properties located in your ward, as approved by you as per the attached, I respectfully request that you introduce the attached ordinance at the next City Council meeting.

If you have any questions regarding this ordinance, please contact Anthony Bertuca at (312) 744-5506.

Department of Business Affairs and Consumer Protection