



City of Chicago



O2013-5225

Office of the City Clerk

Document Tracking Sheet

| | |
|---------------------------------|--|
| Meeting Date: | 6/26/2013 |
| Sponsor(s): | Mell, Richard F. (33) |
| Type: | Ordinance |
| Title: | Awning(s) for VMR Financial Strategies, Inc. |
| Committee(s) Assignment: | Committee on Transportation and Public Way |

ORDINANCE
VMR FINANCIAL STRATEGIES INC.
Acct. No. 337754 - 1
Permit No. 1094050

Be It Ordained by the City Council of the City of Chicago:

SECTION 1. Permission and authority are hereby given and granted to VMR FINANCIAL STRATEGIES INC., upon the terms and subject to the conditions of this ordinance to maintain and use, as now constructed, one (1) Awning(s) projecting over the public right-of-way adjacent to its premises known as 2947 W. Belmont Ave..

Said Awning(s) at W. Belmont measure(s):

One (1) at twenty-three (23) feet in length, and four (4) feet in width for a total of ninety-two (92) square feet.

The location of said privilege shall be as shown on prints kept on file with the Department of Business Affairs and Consumer Protection and the Office of the City Clerk.

Said privilege shall be constructed in accordance with plans and specifications approved by the Zoning Department - Signs.

This grant of privilege in the public way shall be subject to the provisions of Section 10-28-015 and all other required provisions of the Municipal Code of Chicago.

The grantee shall pay to the City of Chicago as compensation for the privilege #1094050 herein granted the sum of fifty (\$50.00) per annum in advance.

A 25% penalty will be added for payments received after due date.

The permit holder agrees to hold the City of Chicago harmless for any damage, relocation or replacement costs associated with damage, relocation or removal of private property caused by the City performing work in the public way.

Authority herein given and granted for a period of five (5) years from and after Date of Passage.

Alderman 

Richard F. Mell 33rd Ward

Awnings Express

8028 S. Western Av. 773.579.1437

| | |
|---------------|----------------------------|
| Date: | 10.15.10 |
| Sales Person: | |
| Address: | 2947 W. Belmont Av. |



**BURGUNDY SUNBRELLA
FABRIC COVER
LACED ON - TYP
(100% PMS 527 COLOR)**

**Frame
Construction**

**3/4" SQ. GALV. STL
TUBING 16 GA. - TYP.
(TOP, BACK & SIDES)**

**5/8" RND. GALV. STL
TUBING - TYP.
(RAFTERS)**

**1/2" RND. GALV. STL
TUBING - TYP.
(LACING ROD)**

**1" SQ. GALV. STEEL
TUBING 16GA - TYP.
(BOTTOM PERIMETER)**

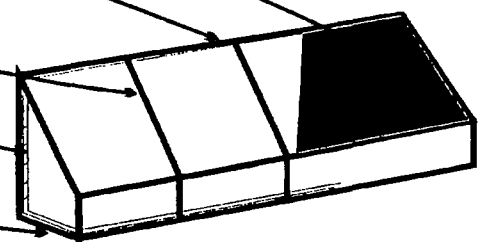

FRAME TO WALL ANCHOR DETAIL

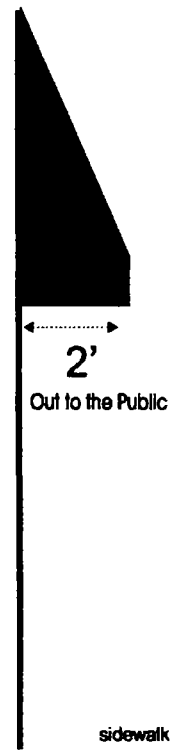
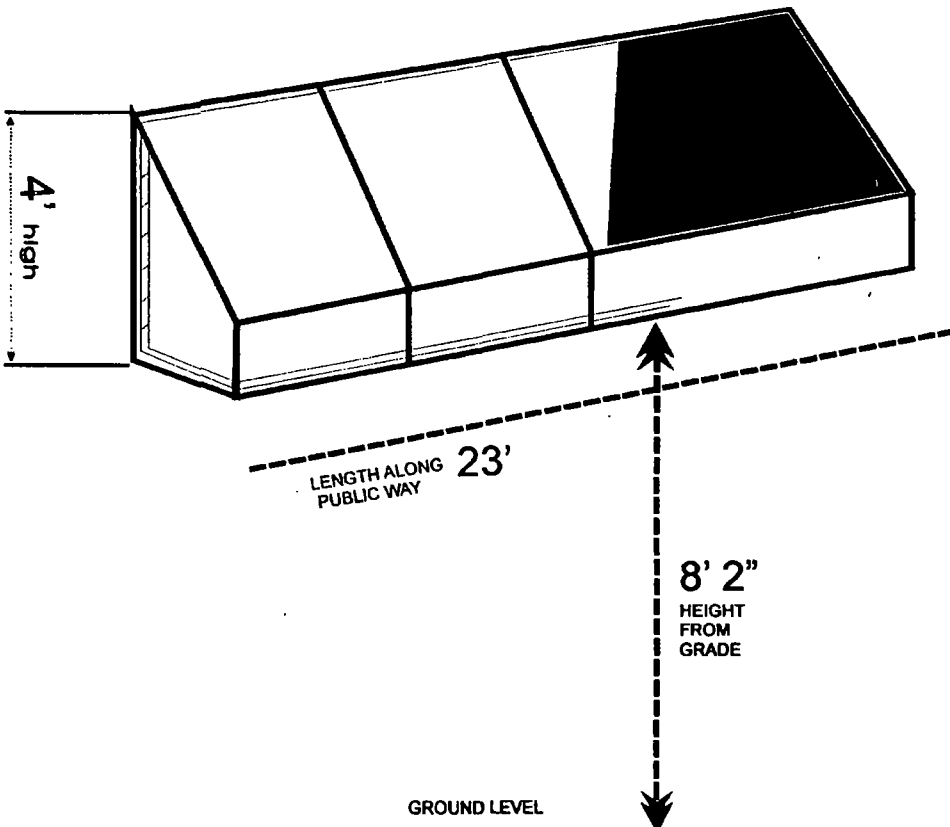
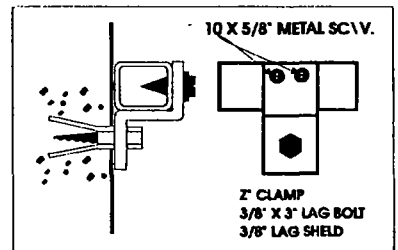



06/26/2013

Alderman Richard F. Mell
Ward # 33
City of Chicago
City Hall, Room 208
121 North LaSalle Street
Chicago, Illinois 60602

Re: An ordinance to use and maintain a portion of the public right-of-way for **one (1) awning(s)** for **VMR FINANCIAL STRATEGIES INC.**, adjacent to the premises known as **2947 W. Belmont Ave.**.

Dear Alderman **Richard F. Mell**:

The applicant referenced above has requested the use of the public right-of-way for a **awning(s)**. An ordinance has been prepared by the Department of Business Affairs and Consumer Protection – Business Assistance Center - Public Way Use Unit for presentation to the City Council. Because this request was made for properties located in your ward, as approved by you as per the attached, I respectfully request that you introduce the attached ordinance at the next City Council meeting.

If you have any questions regarding this ordinance, please contact Anthony Bertuca at (312) 744-5506.

Department of Business Affairs and Consumer Protection