



# City of Chicago



O2018-6269

Office of the City Clerk

## Document Tracking Sheet

<b>Meeting Date:</b>	7/25/2018
<b>Sponsor(s):</b>	Reilly (42)
<b>Type:</b>	Ordinance
<b>Title:</b>	Awning(s) for Pearl Tavern
<b>Committee(s) Assignment:</b>	Committee on Transportation and Public Way

ORDINANCE  
PEARL TAVERN  
Acct. No. 9348 - 1  
Permit No. 1134256

*Be It Ordained by the City Council of the City of Chicago:*

SECTION 1 Permission and authority are hereby given and granted to PEARL TAVERN, upon the terms and subject to the conditions of this ordinance to construct, install, maintain and use two (2) Awning(s) projecting over the public right-of-way adjacent to its premises known as 180 N. Wacker Dr.

Said Awning(s) at N UPPER WACKER DR measure(s):

One (1) at fifteen point four two (15.42) feet in length, and five (5) feet in width for a total of seventy-seven point one (77.1) square feet.

One (1) at thirteen point five (13.5) feet in length, and five (5) feet in width for a total of sixty-seven point five (67.5) square feet

The location of said privilege shall be as shown on prints kept on file with the Department of Business Affairs and Consumer Protection and the Office of the City Clerk.

Said privilege shall be constructed in accordance with plans and specifications approved by the Zoning Department - Signs

This grant of privilege in the public way shall be subject to the provisions of Section 10-28-015 and all other required provisions of the Municipal Code of Chicago.

The grantee shall pay to the City of Chicago as compensation for the privilege #1134256 herein granted the sum of one hundred (\$100.00) per annum in advance.

A 25% penalty will be added for payments received after due date.

The permit holder agrees to hold the City of Chicago harmless for any damage, relocation or replacement costs associated with damage, relocation or removal of private property caused by the City performing work in the public way

Authority herein given and granted for a period of five (5) years from and after Date of Passage.

Alderman \_\_\_\_\_

Brendan Reilly 42nd Ward

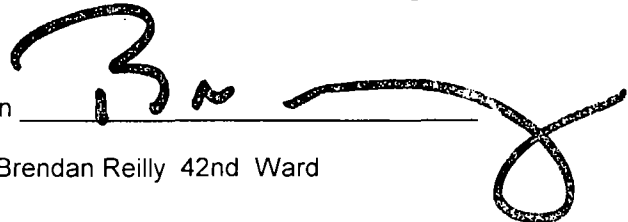
A handwritten signature in black ink, appearing to read 'Brendan Reilly', written over a horizontal line. The signature is stylized and includes a large loop at the end.

Side view, on 2

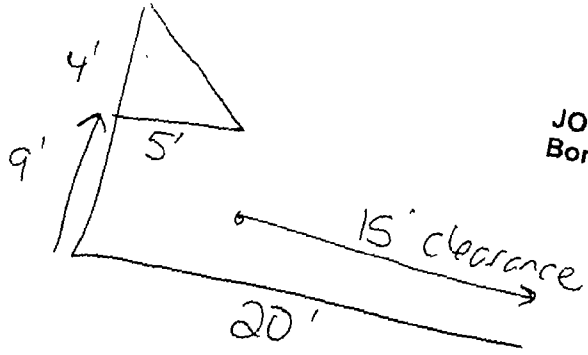
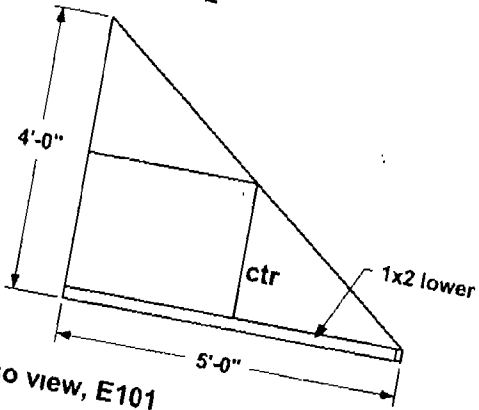

JOB # 731240  
Bonhomme Cafe

Iso view, E101

