



City of Chicago



O2015-2919

Office of the City Clerk

Document Tracking Sheet

Meeting Date:	4/15/2015
Sponsor(s):	Waguespack (32)
Type:	Ordinance
Title:	Grant(s) of privilege in public way for Max Muscle Wicker Park/Bucktown
Committee(s) Assignment:	Committee on Transportation and Public Way

ORDINANCE

Max Muscle Wicker Park/Bucktown

Acct. No. 395982 - 1

Permit No. 1117201

Be It Ordained by the City Council of the City of Chicago:

SECTION 1. Permission and authority are hereby given and granted to Max Muscle Wicker Park/Bucktown, upon the terms and subject to the conditions of this ordinance to maintain and use one (1) sign(s) projecting over the public right-of-way attached to its premises known as 1902 W. North Ave..

Said sign structure(s) measures as follows; along North Avenue:

One (1) at fourteen (14) feet in length, one point six seven (1.67) feet in height and twelve point five (12.5) feet above grade level.

The location of said privilege shall be as shown on prints kept on file with the Department of Business Affairs and Consumer Protection and the Office of the City Clerk.

Said privilege shall be constructed in accordance with plans and specifications approved by the Department of Transportation (Division of Project Development) and Zoning Department - Signs.

This grant of privilege in the public way shall be subject to the provisions of Section 10-28-015 and all other required provisions of the Municipal Code of Chicago.

The grantee shall pay to the City of Chicago as compensation for the privilege #1117201 herein granted the sum of one hundred (\$100.00) per annum in advance.

A 25% penalty will be added for payments received after due date.

The permit holder agrees to hold the City of Chicago harmless for any damage, relocation or replacement costs associated with damage, relocation or removal of private property caused by the City performing work in the public way.

Authority herein given and granted for a period of five (5) years from and after Date of Passage.

Alderman

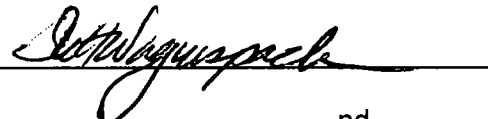

Scott Waguespack 32nd Ward

Front-Lit Channel Letters w/ LED illumination - Raceway Mounted

Proposed Square Footage of this sign:	18sq.ft.
Linear feet of store front:	20'-0"
Actual Square Footage Allowed by village:	20sq.ft.



CHANNEL LETTER - TYPICAL SECTION - FRONT-FIT PLASTIC FACE

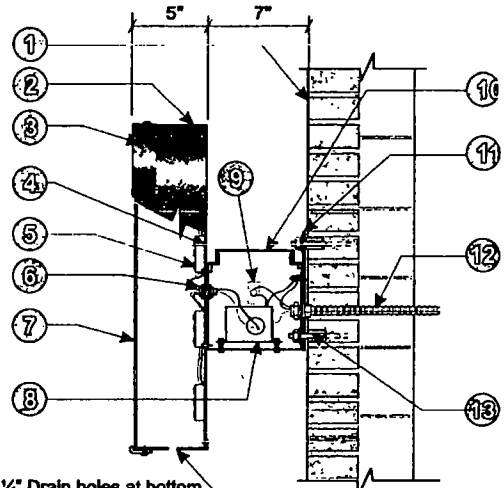

1/2" Drain holes at bottom of letter cans (2) per letter

Section @ LED Channel Letter Raceway mount installation Scale: N.T.S.



- Specifications: LED Channel Letters**
- Existing Facade: Concrete Block/ Brck
 - 0.040" Aluminum letter returns painted to match Black
 - 0.125" x 1" Black Jewelle trimcap
 - .040 White Aluminum backing (interior of sign can will be white for maximum illumination)
 - Interone UL approved red LED's
 - UL approved flexible conduit connectors
 - 1/8" Red Acrylite #Z283
 - UL approved LED transformer (Mean well)
 - UL approved waterproof disconnect switch per NEC 600-6
 - Aluminum Raceway to match fascia color
 - 1/4" x 2" x 11" Aluminum Bracket
 - UL approved Liquid tight metallic conduit (All penetration will be caulked w/ high grade silicone)
 - Mounting hardware to suit (Non-Corrosive)

Electrical Detail: Channel Letters

Mean well CLG-60-12
 (1) 60w Transformers @ 0.80
 Total Amps: 0.80
 (1) Minimum of 20 amp 120V Circuit Req.

- General Notes:**
- This sign is to be installed in accordance with the requirements of Article 600 of the National Electrical Code.
- Grounded and bonded per NEC 600.7/NEC 250
 - Existing branch circuit in compliance with NEC 600.5 not to exceed 20 amps
 - Sign is to be UL listed per NEC 600.3
 - UL disconnect switch per NEC 600.6- required per sign component before leaving manufacturer*
 *For multiple signs, a disconnect is permitted but not required for each section

ELECTRICAL NOTES

Sign Company DOES NOT provide primary electrical to sign.
 Power to the sign must be done by a licensed electrical contractor or licensed electrician.
 Each sign must have:

1. A minimum of one dedicated 120V 20A circuit
2. Junction box installed within 6 feet of sign
3. Three wires: Line, Ground, Neutral



Client: MAX MUSCLE
Address: 1902 W. North
 Chicago 60622
Tel: _____
Email: _____

Landlord: _____
Address: _____
Tel: _____
Email: _____

Start Date: 00/00/0000
Last Revision: 00/00/0000
Job#: 00000
Drawing#: 00000a.v1 s1 / e1
Page: 1 of 2

Client Approval _____
 Landlord Approval _____

Sales Rep: Seung Park
Designer: _____
E322358



Department of Business Affairs and Consumer Protection

Small Business Center - Public Way Use Unit
City Hall - 121 N. LaSalle Street, Room 800 • Chicago, IL 60602
312-74-GOBIZ / 312-744-6249 • (312) 744-1944 (TTY)
<http://www.cityofchicago.org/bacp>

04/15/2015

Alderman Scott Waguespack
Ward # 32
City of Chicago
City Hall, Room 300
121 North LaSalle Street
Chicago, Illinois 60602

Re: An ordinance to use and maintain a portion of the public right-of-way for **one (1) sign(s)** for **Max Muscle Wicker Park/Bucktown**, adjacent to the premises known as **1902 W. North Ave.**.

Dear Alderman **Scott Waguespack**:

The applicant referenced above has requested the use of the public right-of-way for a **sign(s)**. An ordinance has been prepared by the Department of Business Affairs and Consumer Protection – Small Business Center - Public Way Use Unit for presentation to the City Council. Because this request was made for properties located in your ward, as approved by you as per the attached, I respectfully request that you introduce the attached ordinance at the next City Council meeting.

If you have any questions regarding this ordinance, please contact Anthony Bertuca at (312) 744-5506.

Department of Business Affairs and Consumer Protection