



City of Chicago



O2018-6239

Office of the City Clerk

Document Tracking Sheet

Meeting Date:	7/25/2018
Sponsor(s):	Waguespack (32)
Type:	Ordinance
Title:	Awning(s) for Foot Station
Committee(s) Assignment:	Committee on Transportation and Public Way

ORDINANCE
FOOT STATION
Acct. No. 416340 - 4
Permit No. 1133573

Be It Ordained by the City Council of the City of Chicago:

SECTION 1. Permission and authority are hereby given and granted to FOOT STATION, upon the terms and subject to the conditions of this ordinance to construct, install, maintain and use one (1) Awning(s) projecting over the public right-of-way adjacent to its premises known as 2853 N. Lincoln Ave..

Said Awning(s) at N. LINCOLN AVENUE measure(s):

One (1) at twenty-one point six seven (21.67) feet in length, and four (4) feet in width for a total of eighty-six point six eight (86.68) square feet.

The location of said privilege shall be as shown on prints kept on file with the Department of Business Affairs and Consumer Protection and the Office of the City Clerk.

Said privilege shall be constructed in accordance with plans and specifications approved by the Zoning Department - Signs.

This grant of privilege in the public way shall be subject to the provisions of Section 10-28-015 and all other required provisions of the Municipal Code of Chicago.

The grantee shall pay to the City of Chicago as compensation for the privilege #1133573 herein granted the sum of fifty (\$50.00) per annum in advance.

A 25% penalty will be added for payments received after due date.

The permit holder agrees to hold the City of Chicago harmless for any damage, relocation or replacement costs associated with damage, relocation or removal of private property caused by the City performing work in the public way.

Authority herein given and granted for a period of five (5) years from and after Date of Passage.

Alderman 
Scott Waguespack 32nd Ward

SIGN 1: AWNING



SPECIFICATIONS

- 1 AWNING FABRIC MATERIAL
SUNBRELLE BURGUNDY 4631 0000
- 2 1 X 1 SQUARE TUBE FRAME
- 3 3/16 GALVANIZED STEEL Z CLIP ATTACHMENT
- 4 APPROPRIATE NON CORROSIVE WALL FASTENER
3/8 IN ZINC PLATED HEX LAG SCREW
SPACING EACH 4 FT
SEE MOUNTING OPTION DETAILS
- 5 #12 TEK SCREW

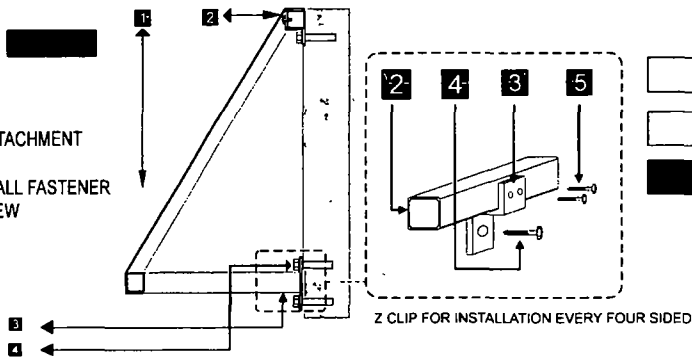

COLOR SCHEDULE

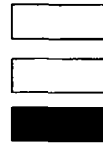

MOUNTING DETAIL

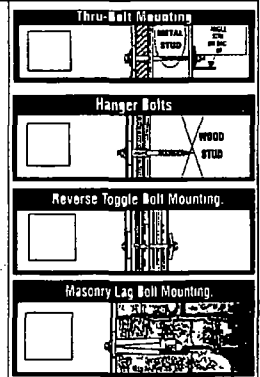

Client Name
Foot Station

Location
2853 N Lincoln Ave
Chicago IL 60657

Start Date 4/20/2018

Last Revision

Job#

Drawing#

Page 4/4

- Client Approval
- Landlord Approval

Sales Rep
kw

Designer
SL



10/10/10



07/25/2018

Alderman Scott Waguespack
Ward # 32
City of Chicago
City Hall, Room 300
121 North LaSalle Street
Chicago, Illinois 60602

Re: An ordinance to use and maintain a portion of the public right-of-way for **one (1) awning(s)** for **FOOT STATION**, adjacent to the premises known as **2853 N. Lincoln Ave.**.

Dear Alderman **Scott Waguespack**:

The applicant referenced above has requested the use of the public right-of-way for a **awning(s)**. An ordinance has been prepared by the Department of Business Affairs and Consumer Protection – Small Business Center - Public Way Use Unit for presentation to the City Council. Because this request was made for properties located in your ward, as approved by you as per the attached, I respectfully request that you introduce the attached ordinance at the next City Council meeting.

If you have any questions regarding this ordinance, please contact Anthony Bertuca at (312) 744-5506.

Department of Business Affairs and Consumer Protection