



# City of Chicago



O2021-2984

Office of the City Clerk

## Document Tracking Sheet

<b>Meeting Date:</b>	7/15/2021
<b>Sponsor(s):</b>	Cappleman (46)
<b>Type:</b>	Ordinance
<b>Title:</b>	Grant(s) of privilege in public way for Wrigleyville Lofts
<b>Committee(s) Assignment:</b>	Committee on Transportation and Public Way

Direct Intro  
# 46

ORDINANCE

N/A

Acct. No.: 474967 - 1

Permit No: BACP1535744

*Be It Ordained by the City Council of the City of Chicago:*

SECTION 1. Permission and authority are hereby given and granted to N/A upon the terms and subject to the conditions of this ordinance to maintain and use one (1) Sign(s) projecting over the public right-of-way attached to its premises known as 949 W DAKIN ST.

Said Sign structure(s) measures as follows along W Dakin Street:  
One (1) at four (4) feet in length, four (4) feet in height and ten (10) feet above grade level.

The location of said privilege shall be as shown on prints kept on file with the Department of Business Affairs and Consumer Protection and the Office of the City Clerk.

Said privilege shall be constructed in accordance with plans and specifications approved by the Zoning Department - Signs.

This grant of privilege in the public way shall be subject to the provisions of Section 10-28-015 and all other required provisions of the Municipal Code of Chicago.

The grantee shall pay to the City of Chicago as compensation for the privilege #BACP1535744 herein granted the sum of one hundred (\$100.00) per annum in advance.

A 25% penalty will be added for payments received after due date.

The permit holder agrees to hold the City of Chicago harmless for any damage, relocation or replacement costs associated with damage, relocation or removal of private property caused by the City performing work in the public way.

Authority herein given and granted for a period of five (5) years from and after Date of Passage.

Alderman:

James Cappleman 46th Ward

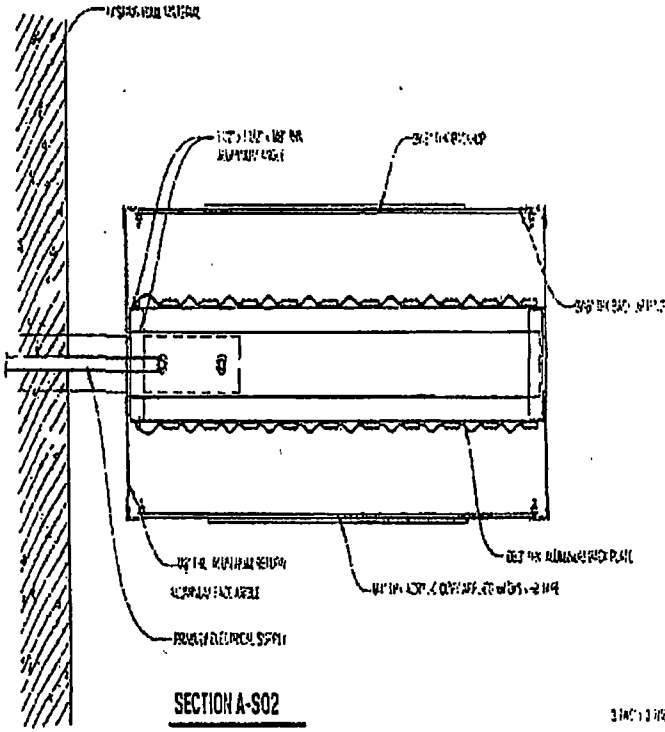

**SECTION A-S02**

SCALE: 1/2" = 1'-0"

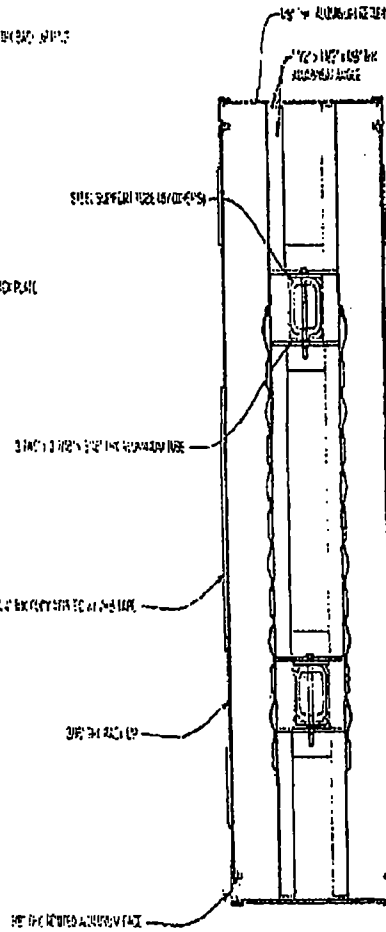

**SECTION B-S02**

SCALE: 1/2" = 1'-0"



1117 E. 11th Street  
Anchorage, Alaska 99501

The drawings are prepared by the contractor and are subject to the approval of the architect. It is the responsibility of the contractor to verify the accuracy of the drawings and to ensure that the work is completed in accordance with the drawings and specifications. The contractor shall be responsible for any errors or omissions in the drawings and specifications.

It is the responsibility of the contractor to verify the accuracy of the drawings and to ensure that the work is completed in accordance with the drawings and specifications.

**Project**  
949 W. OAKIN STREET

04/15/01

Scale: AS NOTED

Project No: 01-11-01

Date:

Revised:

REV	DESCRIPTION	BY	DATE
1			

Prepared by: JIMMY LAM  
Checked by: JIMMY LAM

Scale: AS

**CAB-01**

CH. INTER-LAD CASSETTE

1/2" type

90634

S02

000-000-0000

000