



City of Chicago



SO2020-6226

Office of the City Clerk

Document Tracking Sheet

Meeting Date: 12/16/2020

Sponsor(s): Misc. Transmittal

Type: Ordinance

Title: Zoning Reclassification Map No. 13-I at 2645-2759 W Foster Ave, 2716-2760 W Foster Ave, 2801-2859 W Foster Ave, 2826-2836 W Foster Ave, 5101-5159 N Francisco Ave, 5100-5158 N California Ave, 2724-2758 W Winona Ave, 2739-2759 W Winona Ave, 2800-2858 W Winona Ave and 2801-2850 W Winona Ave - App 20574

Committee(s) Assignment: Committee on Zoning, Landmarks and Building Standards

Final for Publication

SUBSTITUTE ORDINANCE

BE IT ORDAINED BY THE CITY COUNCIL OF THE CITY OF CHICAGO:

SECTION 1. Title 17 of the Municipal Code of Chicago, the Chicago Zoning Ordinance, is hereby amended by changing all the Residential-Institutional Planned Development Number 92, as amended and an RS3 Residential Single-Unit (Detached House) District symbols as shown on Map No. 13-I in the area bounded by:

West Foster Avenue; a line 250 feet west of and parallel to North California Avenue; the alley next north of and parallel to West Foster Avenue; a line 125 feet west of and parallel to North California Avenue; West Foster Avenue; North California Avenue; West Farragut Avenue; the alley next east of North California Avenue the alley next north of West Foster Avenue; a line 441 feet east of North California Avenue; West Foster Avenue; a line 337 feet east of North California Avenue; West Winona Street; a line 217 feet east of North California Avenue and West Carmen Avenue; North Francisco Avenue.

to those of a C1-5 Community Shopping District.

SECTION 2. Title 17 of the Municipal Code of Chicago, the Chicago Zoning Ordinance, is hereby amended by changing all C1-5 Community Shopping District symbols as shown on Map No. 13-I in the area bounded by:

West Foster Avenue; a line 250 feet west of and parallel to North California Avenue; the alley next north of and parallel to West Foster Avenue; a line 125 feet west of and parallel to North California Avenue; West Foster Avenue; North California Avenue; West Farragut Avenue; the alley next east of North California Avenue the alley next north of West Foster Avenue; a line 441 feet east of North California Avenue; West Foster Avenue; a line 337 feet east of North California Avenue; West Winona Street; a line 217 feet east of North California Avenue and West Carmen Avenue; North Francisco Avenue.

to those of Residential-Institutional Planned Development No. 92, as amended which is hereby established in the area above described, subject to the use and bulk regulations set forth in the Plan of Development attached hereto and made a part thereof.

SECTION 3. This ordinance shall be in force and effect from and after its passage and publication.

Address: 2645-2759 West Foster Ave.; 2716-60 West Foster Ave.; 2801-59 West Foster Ave.; 2826-36 West Foster Ave.; 2747-59 West Farragut Ave.; 5100-58 North California Ave.; 2724-58 West Winona Ave.; 2739-59 West Winona Ave.; 2800-58 West Winona Ave.; 2801-59 West Winona Ave.; 5101-59 North Francisco Ave.; 2826-36 West Foster Avenue

Final for Publication

STANDARD PLANNED DEVELOPMENT STATEMENTS

The Planned Development Statements describe the legal regulations and conditions that will control the development of the proposed project. The following statements shall be included in the ordinance; any proposed changes to these statements must be discussed and reviewed with the Chicago Department of Planning and Development. Based on the scope of the project, additional statements (listed at the end of this document) may be required. The following statements must be included in the ordinance:

1. The area delineated herein as Planned Development Number TBD, (Planned Development) consists of a net site area of approximately 599,685 square feet of property which is depicted on the attached Planned Development Boundary and Property Line Map (Property) and is owned or controlled by the Applicant, Swedish Hospital.
2. The requirements, obligations and conditions contained within this Planned Development shall be binding upon the Applicant, its successors and assigns and, if different than the Applicant, the legal title holders and any ground lessors. All rights granted hereunder to the Applicant shall inure to the benefit of the Applicant's successors and assigns and, if different than the Applicant, the legal title holder and any ground lessors. Furthermore, pursuant to the requirements of Section 17-8-0400 of the Chicago Zoning Ordinance, the Property, at the time of application for amendments, modifications or changes (administrative, legislative or otherwise) to this Planned Development are made, shall be under single ownership or designated control. Single designated control is defined in Section 17-8-0400. This Planned Development divides the Property into specifically delineated subareas, each having its own bulk and density standards. Subsequent to adoption of this Planned Development the owners of or designated controlling party for each subarea may seek amendments, changes, or modifications for that subarea without the consent of the owners or designated controlling party of the other subareas in accordance with Sec. 17-8-0400.
3. All applicable official reviews, approvals or permits are required to be obtained by the Applicant or its successors, assignees or grantees. Any dedication or vacation of streets or alleys or grants of easements or any adjustment of the right-of-way shall require a separate submittal to the Department of Transportation on behalf of the Applicant or its successors, assigns or grantees.

Any requests for grants of privilege, or any items encroaching on the public way, shall be in compliance with the Planned Development.

Ingress or egress shall be pursuant to the Planned Development and may be subject to the review and approval of the Departments of Planning and Development and Transportation. Closure of all or any public street or alley during demolition or construction shall be subject to the review and approval of the Department of Transportation.

Applicant.	Swedish Hospital
Address	2826-36 West Foster Avenue
Introduced	December 16, 2020
Plan Commission	September 16, 2021

Final for Publication

Pursuant to a negotiated and executed Perimeter Restoration Agreement (“Agreement”) by and between the Department of Transportation’s Division of Infrastructure Management and the Applicant, the Applicant shall provide improvements and restoration of all public way adjacent to the property, which may include, but not be limited to, the following as shall be reviewed and determined by the Department of Transportation’s Division of Infrastructure Management:

- Full width of streets
- Full width of alleys
- Curb and gutter
- Pavement markings
- Sidewalks
- ADA crosswalk ramps
- Parkway & landscaping

The Perimeter Restoration Agreement must be executed prior to any Department of Transportation and Planned Development Part II review permitting. The Agreement shall reflect that all work must comply with current Rules and Regulations and must be designed and constructed in accordance with the Department of Transportation’s Construction Standards for work in the Public Way and in compliance with the Municipal Code of Chicago Chapter 10-20. Design of said improvements should follow the Department of Transportation’s Rules and Regulations for Construction in the Public Way as well as The Street and Site Plan Design Guidelines. Any variation in scope or design of public way improvements and restoration must be approved by the Department of Transportation.

4. This Plan of Development consists of seventeen (17) Statements: a Bulk Regulations Table; an Existing Zoning Map; an Existing Land-Use Map; a Planned Development Boundary and Property Line Map; Proposed Site Plan; Sub-Area Map; Floor Plans; Landscape Plans; a Roof Plan; and, Building Elevations (North, South, East and West) prepared by Jensen & Halstead Architects and dated (date of Plan Commission presentation), submitted herein. Full-sized copies of the Site Plan, Landscape Plan and Building Elevations are on file with the Department of Planning and Development. In any instance where a provision of this Planned Development conflicts with the Chicago Building Code, the Building Code shall control. This Planned Development conforms to the intent and purpose of the Chicago Zoning Ordinance, and all requirements thereto, and satisfies the established criteria for approval as a Planned Development. In case of a conflict between the terms of this Planned Development Ordinance and the Chicago Zoning Ordinance, this Planned Development shall control.

Applicant	Swedish Hospital
Address	2826-36 West Foster Avenue
Introduced	December 16, 2020
Plan Commission	September 16, 2021

27947860v18

Final for Publication

5. The following uses are permitted in the area delineated herein as a Planned Development 92, as amended:

Subarea A: Hospital and related uses; health & fitness facilities; Assisted Living facilities; Daycare facilities; Medical and administrative offices; Parking & accessory uses; Nursing Home (Skilled Nursing Care); Colleges and Universities, Cultural Exhibits and Libraries; Parks and Recreation (including community garden), Fire Station, Religious Assembly, School and Utilities and Services - Minor.

Subarea B: Medical service; Hospital and related uses; health & fitness facilities; Office; Medical and administrative offices, daycare facilities; Restaurant (Limited); Retail, Parking and accessory uses.

6. On-Premise signs and temporary signs, such as construction and marketing signs, shall be permitted within the Planned Development, subject to the review and approval of the Department of Planning and Development. Off-Premise signs are prohibited within the boundary of the Planned Development.
7. For purposes of height measurement, the definitions in the Chicago Zoning Ordinance shall apply. The height of any building shall also be subject to height limitations, if any, established by the Federal Aviation Administration.
8. The maximum permitted floor area ratio (FAR) for the Property shall be in accordance with the attached Bulk Regulations and Data Table. For the purpose of FAR calculations and measurements, the definitions in the Zoning Ordinance shall apply. The overall permitted FAR identified in the Bulk Regulations and Data Table has been determined using a net site area of 599,685 square feet and an overall maximum base FAR of 1.4.
9. Upon review and determination, Part II Review, pursuant to Section 17-13-0610, a Part II Review Fee shall be assessed by the Department of Planning and Development. The fee, as determined by staff at the time, is final and binding on the Applicant and must be paid to the Department of Revenue prior to the issuance of any Part II approval.
10. The Site and Landscape Plans shall be in substantial conformance with the Landscape Ordinance and any other corresponding regulations and guidelines, including Section 17-13-0800. Final landscape plan review and approval will be by the Department of Planning and Development. Any interim reviews associated with site plan review or Part II reviews, are conditional until final Part II approval. The Applicant proposes a Tree planting program which will include the planting of twenty (20) new trees per year for a period of three (3) years.

Applicant	Swedish Hospital
Address	2826-36 West Foster Avenue
Introduced	December 16, 2020
Plan Commission	September 16, 2021

Final for Publication

11. The Applicant agrees to collaborate with the Department with regard to the artistic treatment of the east façade of the building proposed to be constructed in Subarea B. Final review and approval of the design will be by the Department.
12. The Applicant shall comply with Rules and Regulations for the Maintenance of Stockpiles promulgated by the Commissioners of the Departments of Streets and Sanitation, Fleet and Facility Management and Buildings, under Section 13-32-085, or any other provision of the Municipal Code of Chicago.
13. The terms and conditions of development under this Planned Development ordinance may be modified administratively, pursuant to Section 17-13-0611-A, by the Zoning Administrator upon the application for such a modification by the Applicant, its successors and assigns and, if different than the Applicant, the legal title holders and any ground lessors.
14. The Applicant acknowledges that it is in the public interest to design, construct and maintain the project in a manner which promotes, enables and maximizes universal access throughout the Property. Plans for all buildings and improvements on the Property shall be reviewed and approved by the Mayor's Office for People with Disabilities to ensure compliance with all applicable laws and regulations related to access for persons with disabilities and to promote the highest standard of accessibility.
15. The Applicant acknowledges that it is in the public interest to design, construct, renovate and maintain all buildings in a manner that provides healthier indoor environments, reduces operating costs and conserves energy and natural resources. The Applicant shall obtain the number of points necessary to meet the requirements of the Chicago Sustainable Development Policy, in effect at the time the Part II review process is initiated for each improvement that is subject to the aforementioned Policy and must provide documentation verifying compliance.
16. The Applicant acknowledges that it is the policy of the City to maximize opportunities for Minority and Women-owned Business Enterprises ("M/WBEs") and city residents to compete for contracts and jobs on construction projects approved through the planned development process. To assist the city in promoting and tracking such M/WBE and city resident participation, an applicant for planned development approval shall provide information at three points in the city approval process. First, the applicant must submit to DPD, as part of its application for planned development approval, an M/WBE Participation Proposal. The M/WBE Participation Proposal must identify the applicant's goals for participation of certified M/WBE firms in the design, engineering and construction of the project, and of city residents in the construction work. The city encourages goals of (i) 26% MBE and 6% WBE participation (measured against the total construction budget for the project or any phase thereof), and (ii) 50% city resident hiring (measured against the total construction work hours for the project or any phase thereof). The M/WBE Participation

Applicant	Swedish Hospital
Address	2826-36 West Foster Avenue
Introduced	December 16, 2020
Plan Commission	September 16, 2021

27947860v18

Final for Publication

Proposal must include a description of the Applicant's proposed outreach plan designed to inform M/WBEs and city residents of job and contracting opportunities. Second, at the time of the Applicant's submission for Part II permit review for the project or any phase thereof, the Applicant must submit to DPD (a) updates (if any) to the Applicant's preliminary outreach plan, (b) a description of the Applicant's outreach efforts and evidence of such outreach, including, without limitation, copies of certified letters to M/WBE contractor associations and the ward office of the alderman in which the project is located and receipts thereof; (c) responses to the Applicant's outreach efforts, and (d) updates (if any) to the applicant's M/WBE and city resident participation goals. Third, prior to issuance of a Certificate of Occupancy for the project or any phase thereof, the Applicant must provide DPD with the actual level of M/WBE and city resident participation in the project or any phase thereof, and evidence of such participation. In addition to the forgoing, DPD may request such additional information as the department determines may be necessary or useful in evaluating the extent to which M/WBEs and city residents are informed of and utilized in planned development projects. All such information will be provided in a form acceptable to the Zoning Administrator. DPD will report the data it collects regarding projected and actual employment of M/WBEs and city residents in planned development projects twice yearly to the Chicago Plan Commission and annually to the Chicago City Council and the Mayor.

17. This Planned Development shall be governed by Section 17-13-0612. Should this Planned Development ordinance lapse, the Zoning Administrator shall initiate a Zoning Map Amendment to rezone the property to C1-5 Neighborhood Commercial District.

Applicant	Swedish Hospital
Address	2826-36 West Foster Avenue
Introduced	December 16, 2020
Plan Commission	September 16, 2021

Final for Publication

RESIDENTIAL- INSTITUTIONAL PLANNED DEVELOPMENT NO. 92 BULK REGULATIONS AND DATA TABLE

Gross Site Area (sf):	780,300 s.f.
Area of Public Right of Way (sf):	180,615 s.f.
Net Site Area (sf):	599,685 s.f. <ul style="list-style-type: none">• Subarea A: 584,061 s.f.• Subarea B: 15,624 s.f.
Maximum Permitted Floor Area Ratio:	1.4 (Overall FAR) <ul style="list-style-type: none">• Subarea A = 1.33• Subarea B = 4.13
Allowed Uses:	All uses identified in Statement Number 5
No. of Off-street Parking Spaces:	<ul style="list-style-type: none">• Subarea A = 1,605• Subarea B = 32
No. of Bicycle Spaces:	<ul style="list-style-type: none">• Subarea A = Existing• Subarea B= 36<ul style="list-style-type: none">> 6 (exterior)> 30 (interior)
No. of Off-Street Loading Berths:	Subarea A (Existing): <ul style="list-style-type: none">• For Ambulatory Center: 0• For Ambulatory/Surgery Center West of California Avenue: 2• For Assisted Living Facility North of Foster Avenue: 1 Subarea B: <ul style="list-style-type: none">• Medical Outpatient Center: 1 (10' x 25')
Maximum Building Height:	108 ft. (overall building height) 96 ft. (zoning height)
Setbacks from Property Line:	In accordance with Site Plan
Maximum No. of Hospital Beds:	340 (Subarea A) 0 (Subarea B)
Maximum No. of Assisted Living Units:	56 (Subarea A) 0 (Subarea B)

Applicant	Swedish Hospital
Address	2826-36 West Foster Avenue
Introduced	December 16, 2020
Plan Commission	September 16, 2021

Final for Publication

EXISTING ZONING MAP

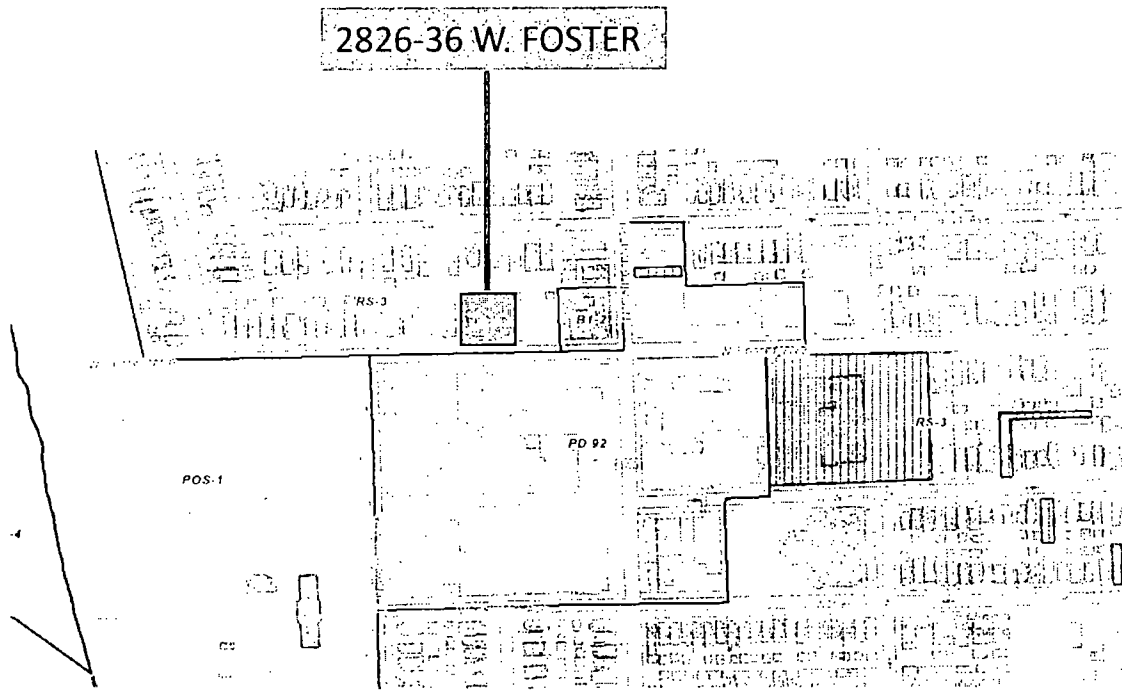

Applicant: Swedish Hospital
Address: 2826-36 West Foster Avenue
Date of Introduction: December 16, 2020
Plan Commission Hearing: September 16, 2021

Final for Publication

EXISTING LAND USE MAP

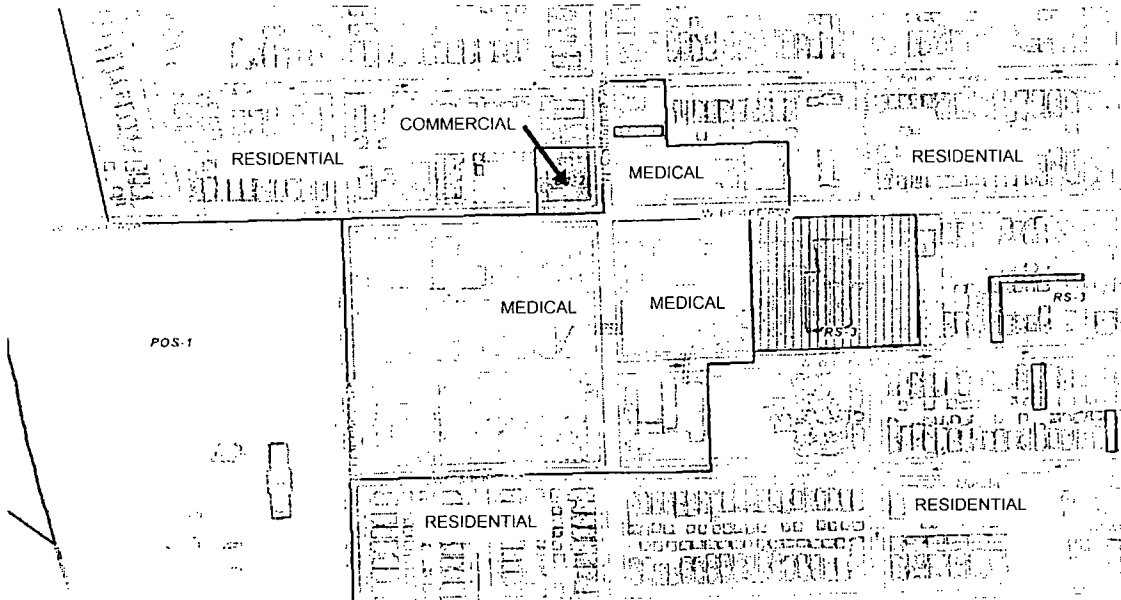

Applicant: Swedish Hospital
Address: 2826-36 West Foster Avenue
Date of Introduction: December 16, 2020
Plan Commission Hearing: September 16, 2021

Final for Publication

PLANNED DEVELOPMENT BOUNDARY MAP

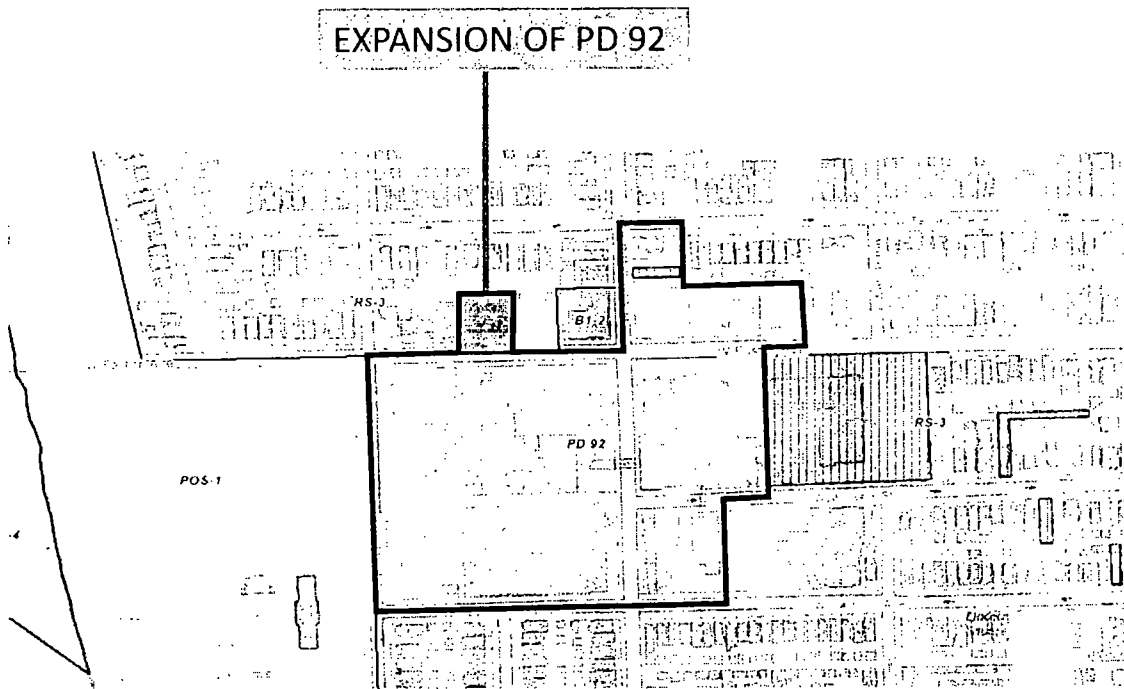

Applicant: Swedish Hospital
Address: 2826-36 West Foster Avenue
Date of Introduction: December 16, 2020
Plan Commission Hearing: September 16, 2021

Final for Publication



PROPOSED SITE PLAN

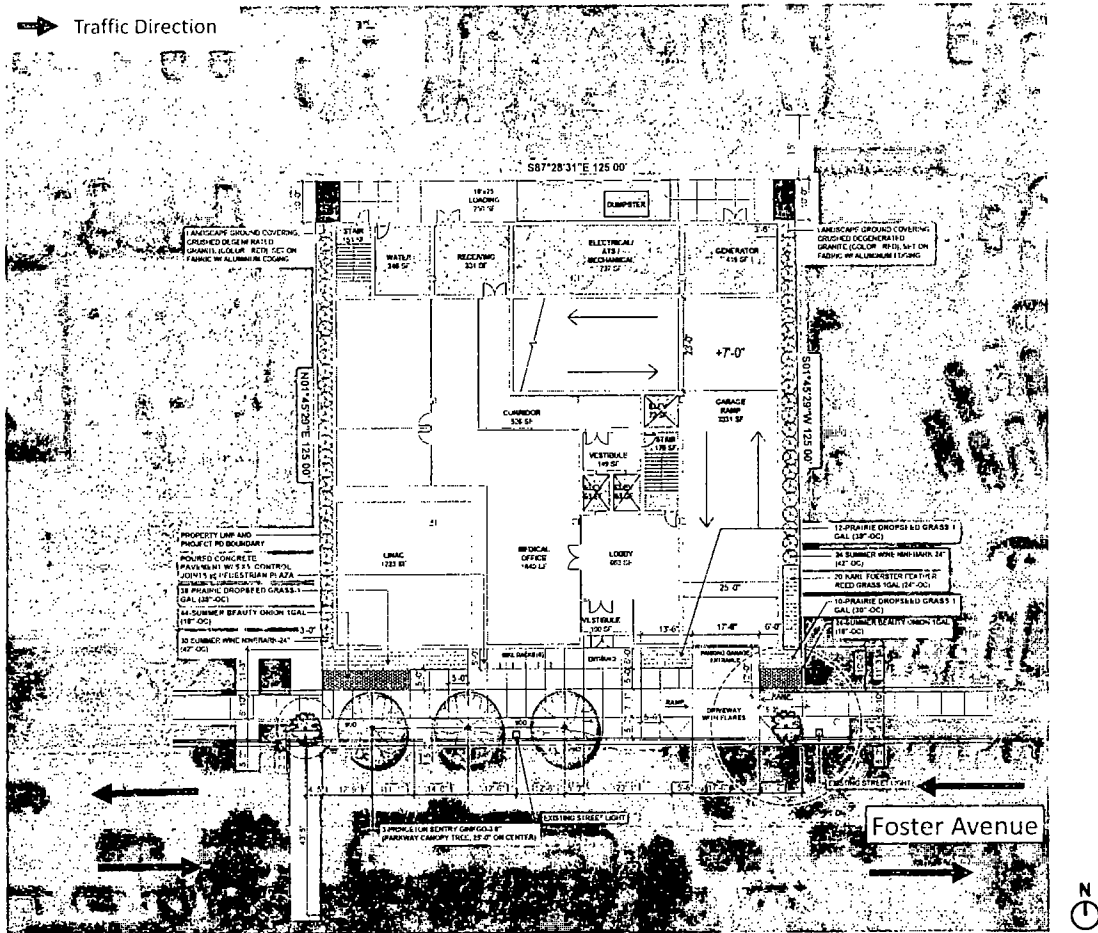

Applicant: Swedish Hospital
 Address: 2826-36 West Foster Avenue
 Date of Introduction: December 16, 2020
 Plan Commission Hearing: September 16, 2021

Final for Publication

SUB-AREA MAP

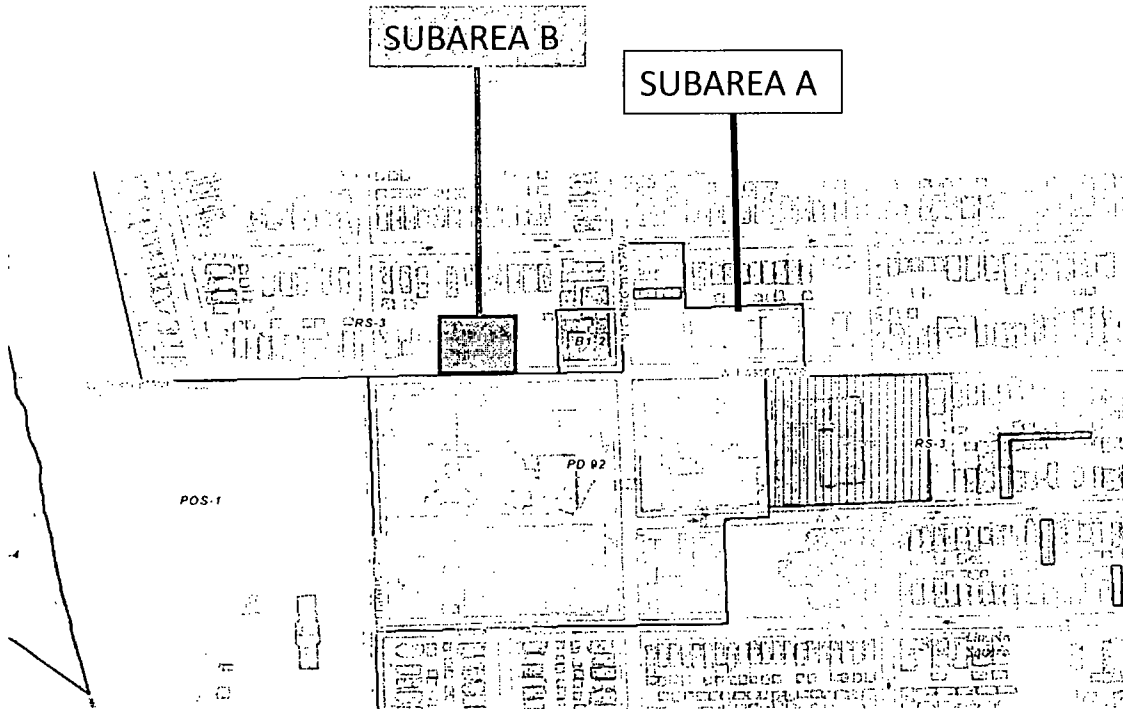

Applicant: Swedish Hospital
Address: 2826-36 West Foster Avenue
Date of Introduction: December 16, 2020
Plan Commission Hearing: September 16, 2021

Final for Publication

FLOOR PLANS

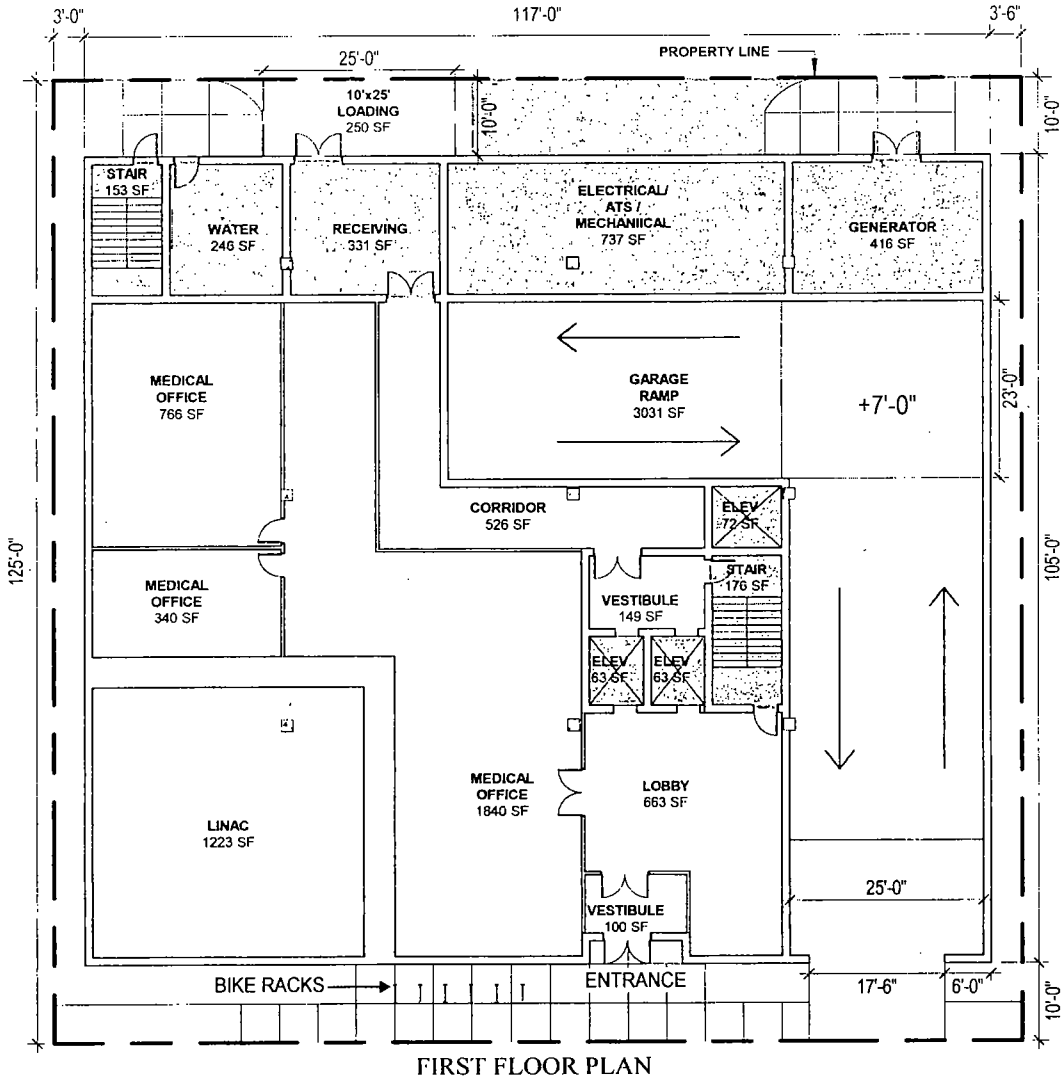

Applicant: Swedish Hospital
Address: 2826-36 West Foster Avenue
Date of Introduction: December 16, 2020
Plan Commission Hearing: September 16, 2021

Final for Publication

FLOOR PLANS

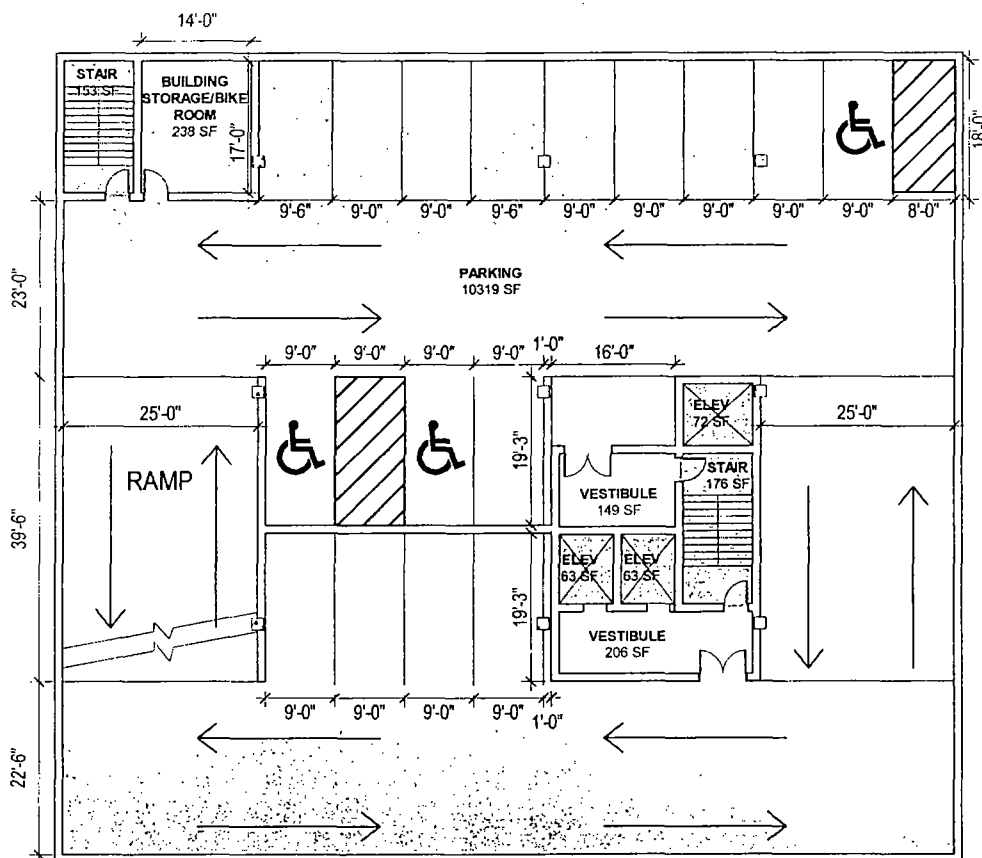

FLOORS 2-3

Applicant: Swedish Hospital
Address: 2826-36 West Foster Avenue
Date of Introduction: December 16, 2020
Plan Commission Hearing: September 16, 2021

Final for Publication

FLOOR PLANS

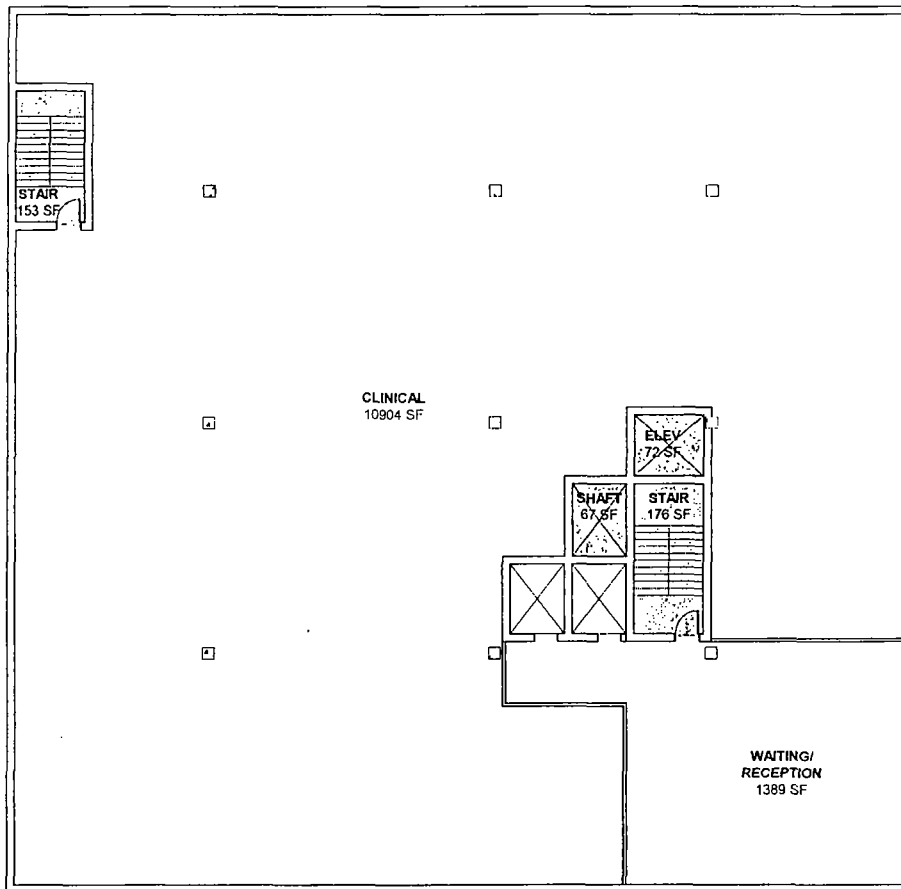

FLOORS 4-7

Applicant: Swedish Hospital
Address: 2826-36 West Foster Avenue
Date of Introduction: December 16, 2020
Plan Commission Hearing: September 16, 2021

GARAGE RAMP
RAMP UP
3031 SF

+7'-0"

S01°45'29"W 125.00'

CORRIDOR
526 SF

ELEV
72 SF

STAIR
176 SF

VESTIBULE
149 SF

ELEV
63 SF

ELEV
63 SF

MEDICAL OFFICE
1840 SF

LOBBY
663 SF

PROPOSED BIKE RACKS (6)

NEW STORM SEWER

VESTIBULE
100 SF

ENTRANCE

LANDSCAPE PLANTINGS

NEW SANITARY SEWER

PARKING GARAGE ENTRANCE

N87°28'31"W 125.00'

TREE NO. 2:
PRESERVE EXISTING HONEY LOCUST @ 24" CALIPER, FAIR CONDITION (DASHED LINE REPRESENTS TREE CANOPY, 1" TRUNK DIAMETER IS EQUAL TO 1.5' CANOPY SPREAD)

TREE PROTECTION FENCE (6' HIGH CHAINLINK FENCE W/ STURDY STEEL SUPPORT POSTS SPACED EQUALLY)

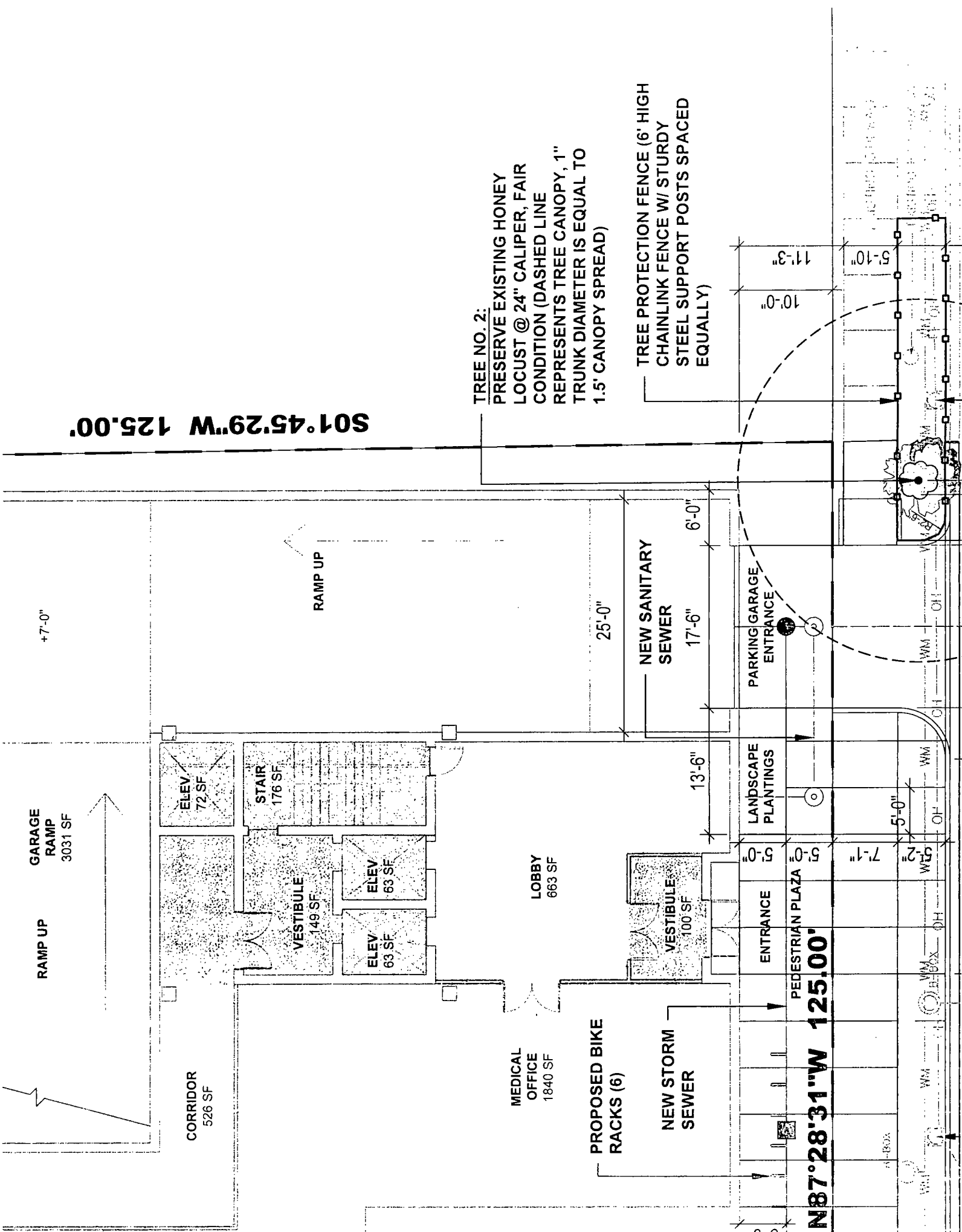

S01°45'29"W 125.00'

+7'-0"

RAMP UP
GARAGE RAMP
3031 SF

RAMP UP

CORRIDOR
526 SF

ELEV
72 SF

STAIR
176 SF

VESTIBULE
149 SF

ELEV
63 SF

ELEV
63 SF

MEDICAL OFFICE
1840 SF

LOBBY
663 SF

PROPOSED BIKE RACKS (6)

NEW STORM SEWER

VESTIBULE
100 SF

ENTRANCE

PEDESTRIAN PLAZA

P°28'31"W 125.00'

NEW SANITARY SEWER

PARKING GARAGE ENTRANCE

SITE LANDSCAPE SOIL - APPROVED IMPORTED TOPSOIL PLACED @ 18" DEPTH IN COMPACTED LAYERS; FINISH GRADE TO MATCH ADJACENT CONTROLS AND TOP OF PAVEMENT - ALLOW 3-4" FOR CULTIVATION, SOIL AMENDMENTS, AND FINAL LAYER OF ORGANIC MULCH (TYP.)

10'-0"
11'-3"

5'-10"

5'-0"

5'-0"

7'-4"

5'-2"

5'-0"

5'-0"

5'-0"

5'-0"

5'-0"



S01°45'29"W 125.00'

NOTE: ESTIMATED TIME OF PLANTING IS TARGETED FOR SPRING OF 2023, PENDING CONSTRUCTION

- 12-PRAIRIE DROPSEED GRASS-1 GAL (30"-OC)
- 24-SUMMER WINE NINEBARK-24" (42"-OC)
- 20-KARL FOERSTER FEATHER REED GRASS-1GAL (24"-OC)
- 12' SIGHT TRIANGLE
- 10-PRAIRIE DROPSEED GRASS-1 GAL (30"-OC)
- 24-SUMMER BEAUTY ONION-1GAL (18"-OC)

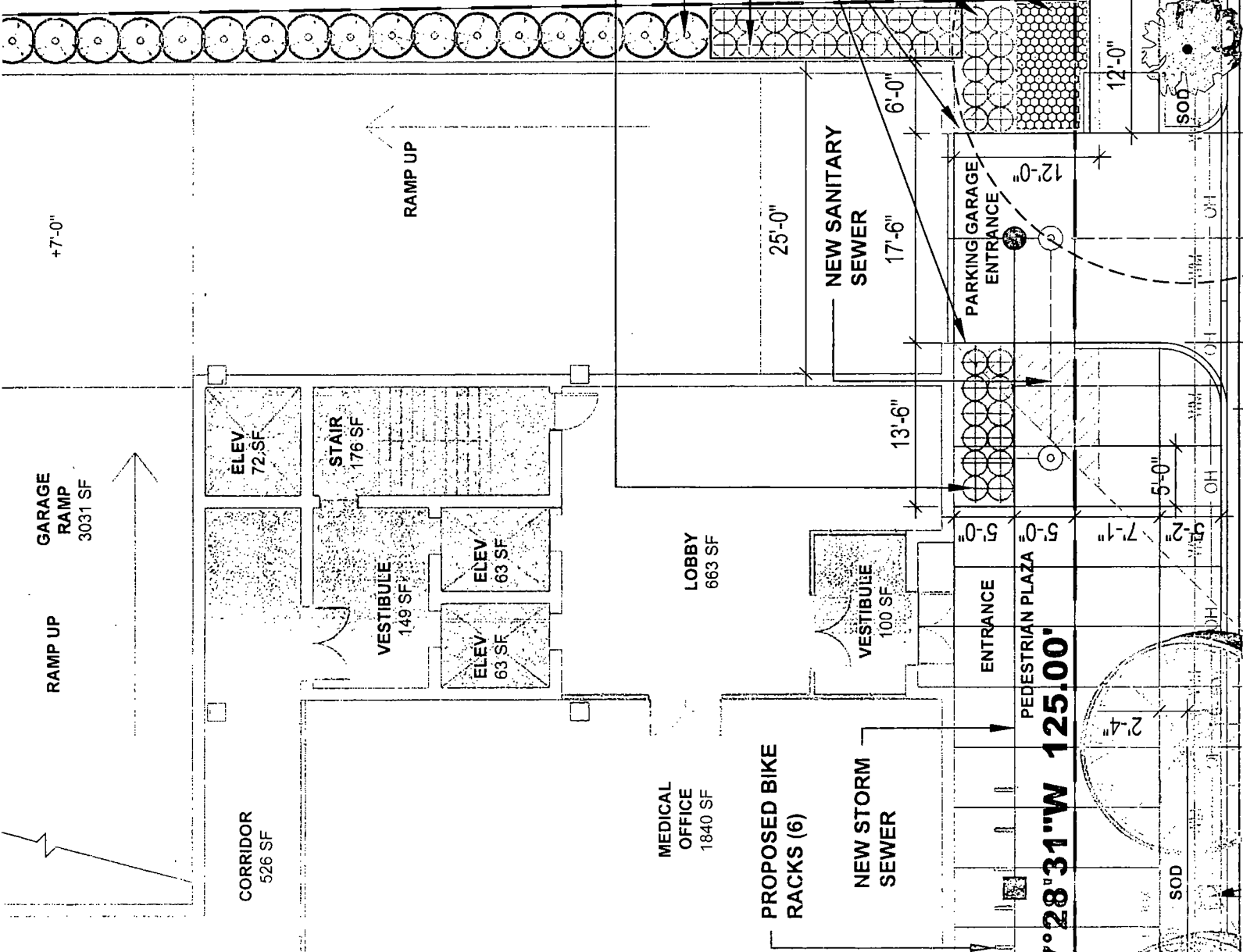

GARAGE RAMP
3031 SF

RAMP UP

+7'-0"

RAMP UP

CORRIDOR
526 SF

MEDICAL OFFICE
1840 SF

LOBBY
863 SF

STAIR
176 SF

VESTIBULE
149 SF

ELEV
63 SF

ELEV
63 SF

ELEV
72 SF

PROPOSED BIKE RACKS (6)

NEW STORM SEWER

NEW SANITARY SEWER

ENTRANCE

PARKING GARAGE ENTRANCE

PEDESTRIAN PLAZA

S02°28'31"W 125.00'

SOD

SOD

OH

OH

OH

OH

OH

OH

OH

OH

OH

2'-4"

5'-0"

12'-0"

12'-0"

10'-0"

11'-3"

5'-10"

5'-10"

5'-10"

EXISTING PAV. CONC. W/PAV. MARKING

EXISTING PAV. CONC. W/PAV. MARKING

EXISTING PAV. CONC. W/PAV. MARKING

EXISTING PAV. CONC. W/PAV. MARKING

EXISTING PAV. CONC. W/PAV. MARKING

EXISTING PAV. CONC. W/PAV. MARKING

Weather Reed Grass

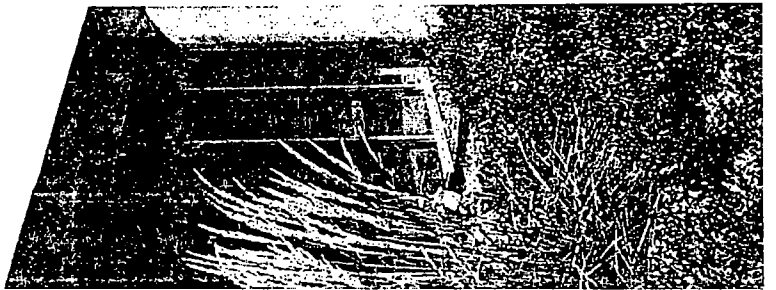
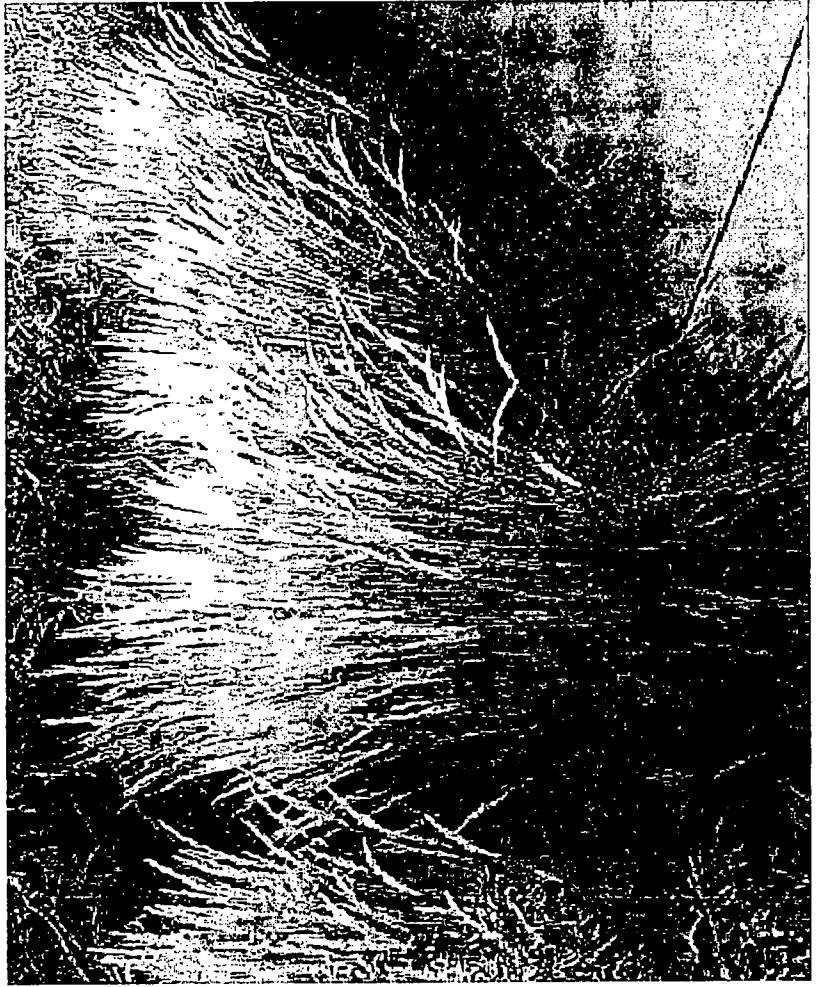

105'-0"

3'-0"

5'-0"

5'-6"

104'-0"

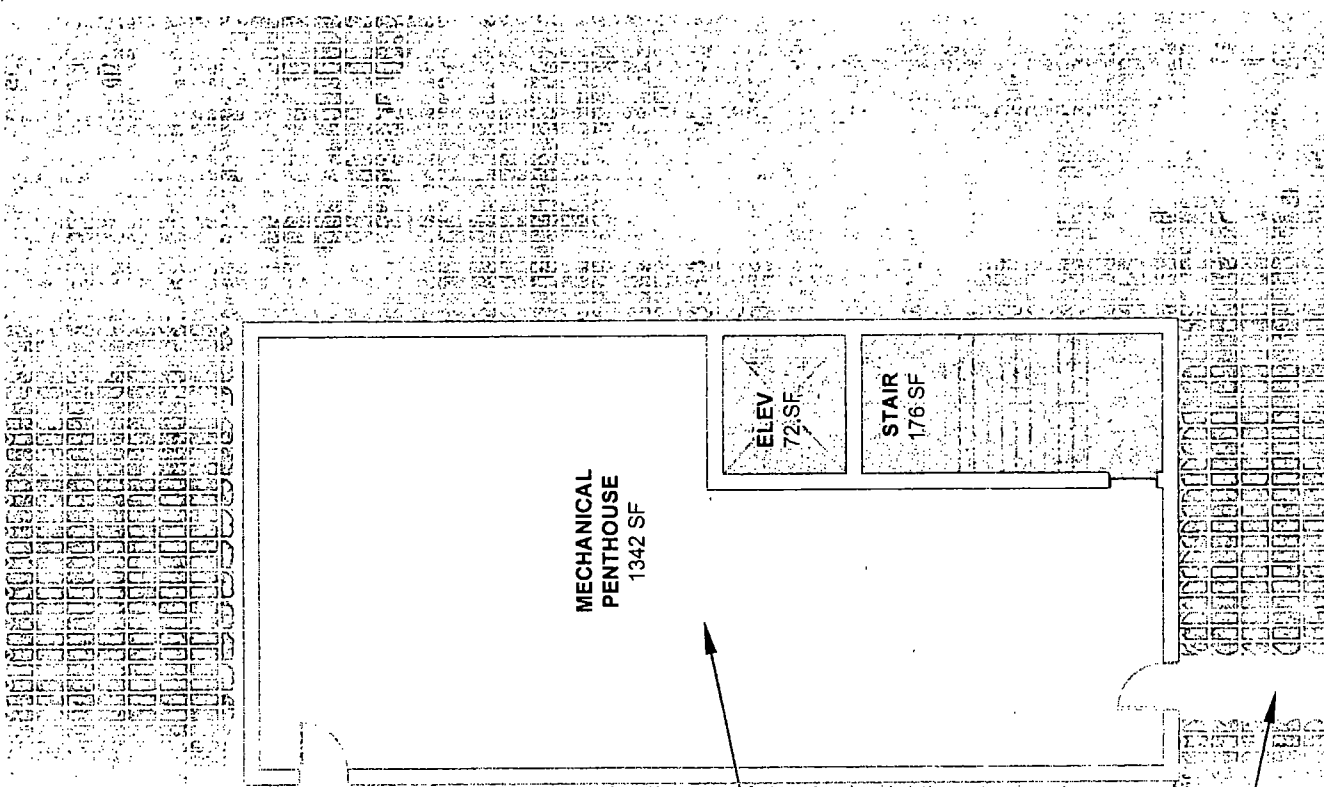

MECHANICAL
PENTHOUSE
1342 SF

ELEV
72 SF

STAIR
176 SF

ROPE, TIES & BURLAP FROM BALL (TREES 4" OR LARGER, PERFORM SAME 1-YEAR AFTER PLANTING)

PROVIDE 3" LAYER OF PREMIUM SHREDDED HARDWOOD, DO NOT CONTACT TRUNK/ROOT FLARE W/ MULCH

SET ROOTBALL ON UNDISTURBED SOIL BACKFILL W/ SPECIFIED AMENDED PLANTING SOIL

PCC SIDEWALK, SEE CIVIL PLANS AGGREGATE BASE COMPACTED SUBGRADE

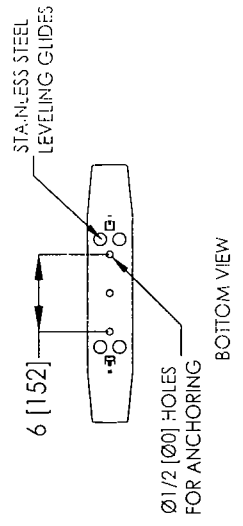
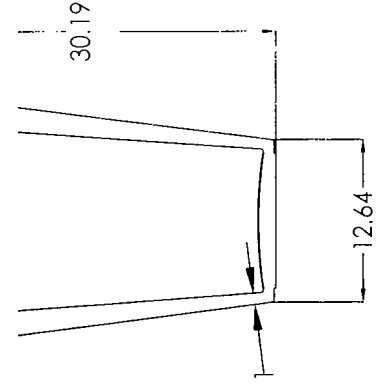
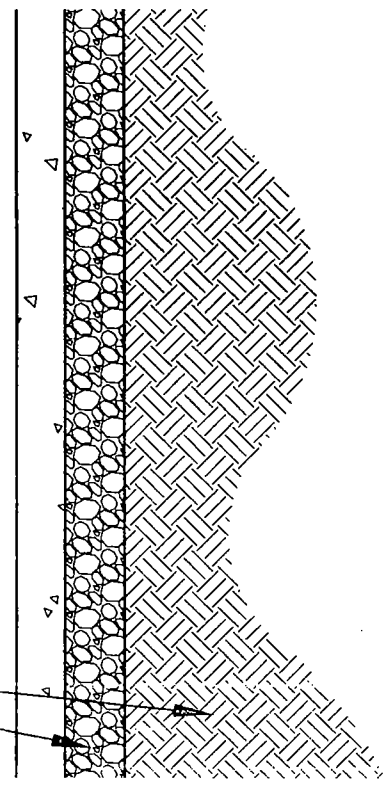

BOTTOM VIEW

landscapeforms
 Drawing: NL696-02
 Dimensions are in inches [mm]
 Spanish Industrial Design | 51.245

CONFIDENTIAL DRAWING INFORMATION CONTAINED HEREIN IS THE PROPERTY OF LANDSCAPE FORMS, INC. INTENDED USE IS LIMITED TO DESIGN PROFESSIONALS SPECIFYING LANDSCAPE FORMS, INC. PRODUCTS AND THEIR DIRECT CLIENTS. DRAWING IS NOT TO BE COPIED OR DISCLOSED TO OTHERS WITHOUT THE CONSENT OF LANDSCAPE FORMS, INC.
 © 2013 LANDSCAPE FORMS, INC. ALL RIGHTS RESERVED

Bike Rack

2 Scale 1"=1'-0"

AND FURTHER A CONTINUOUS CORNER.

4. PERMALOC ASPHALT-EDGE AS MANUFACTURED BY PERMALOC CORPORATION, HOLLAND MI. (800) 356-9660

5. CONTRACTOR'S NOTE: FOR PRODUCT AND PURCHASING INFORMATION VISIT: WWW.PERMALOC.COM

Aluminium Edging

Not to Scale

2

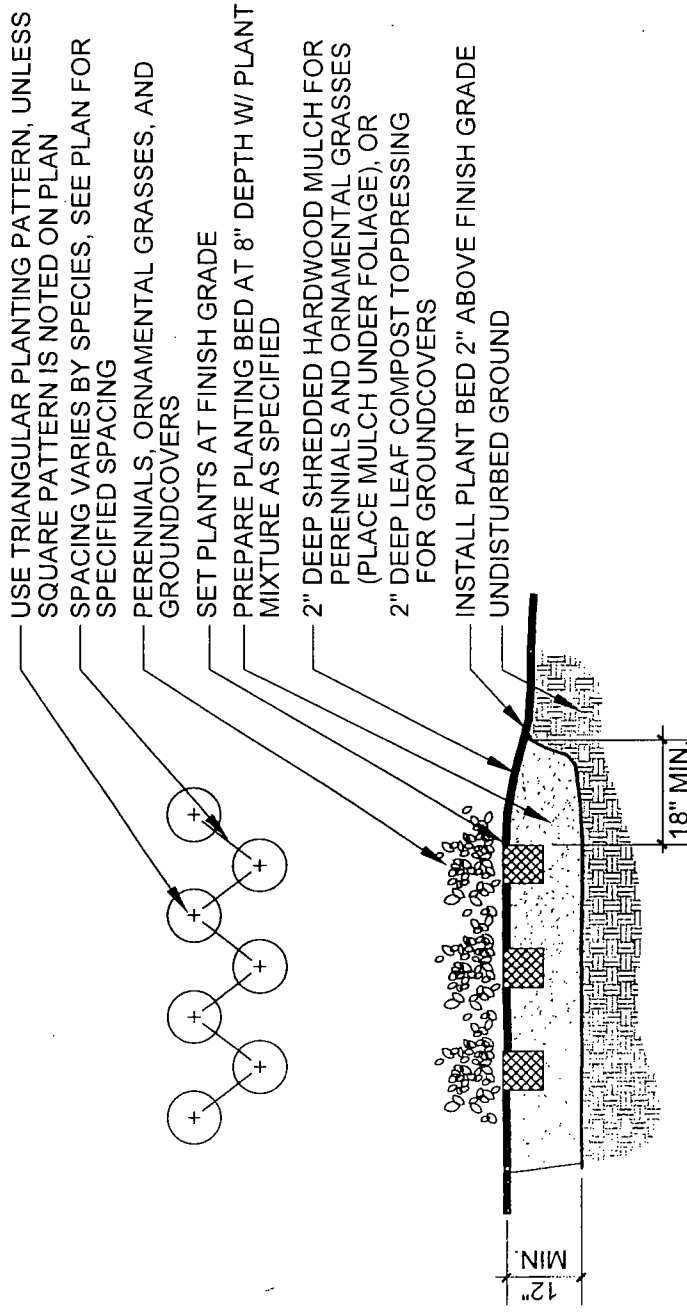
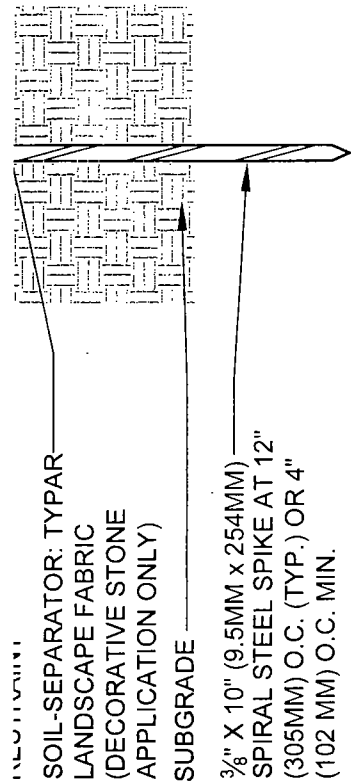

Perennial & Groundcover Planting

Not to Scale

4

Final for Publication

FLOOR PLANS

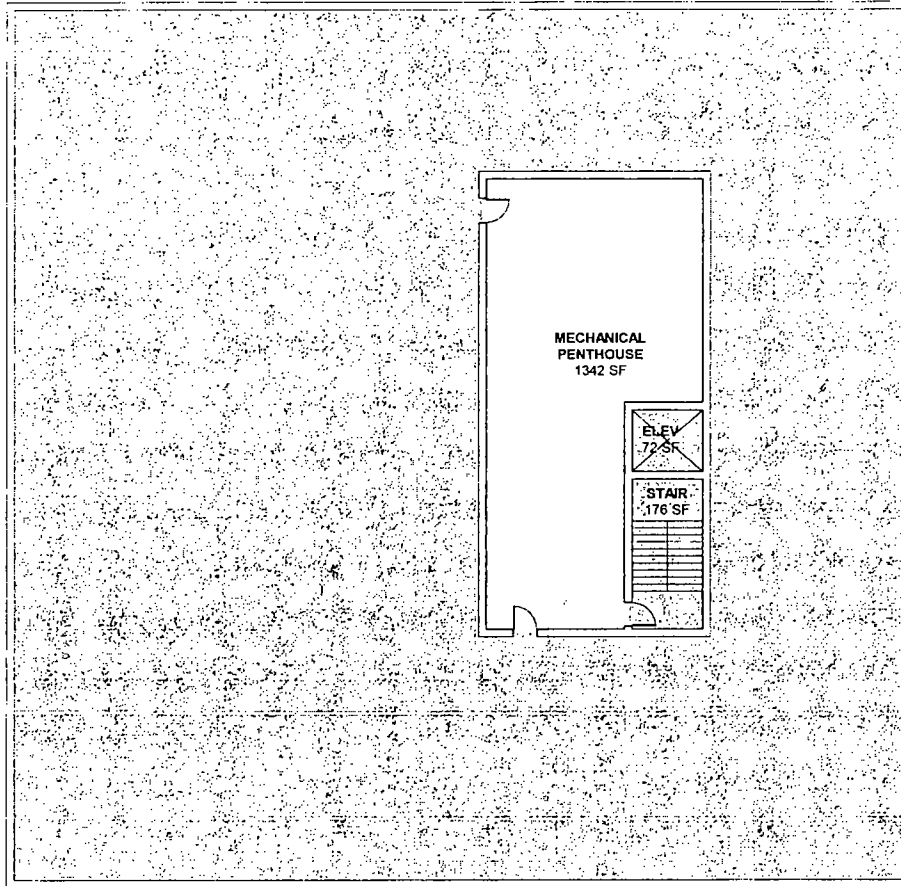

ROOF PLAN

Applicant: Swedish Hospital
Address: 2826-36 West Foster Avenue
Date of Introduction: December 16, 2020
Plan Commission Hearing: September 16, 2021

Final for Publication

ELEVATIONS

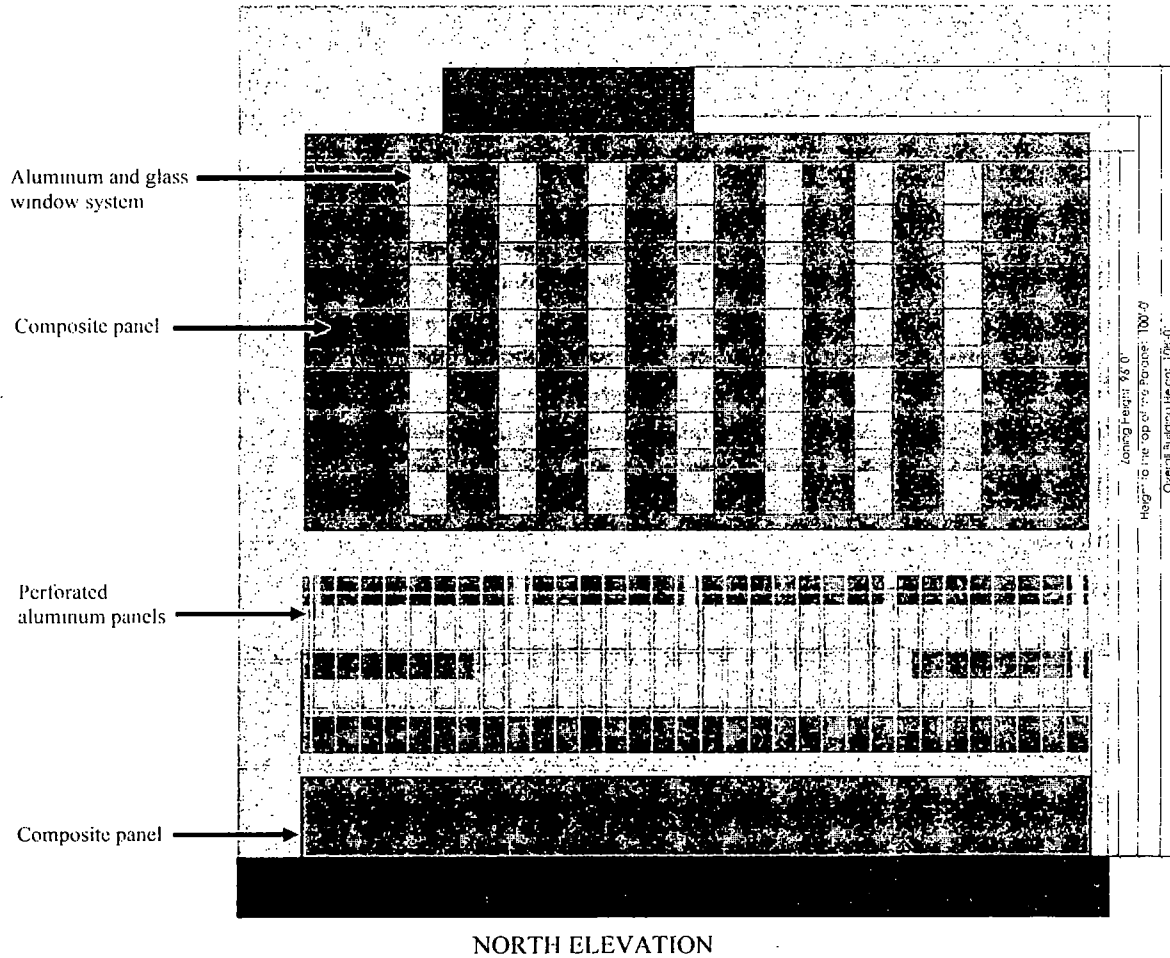

Applicant: Swedish Hospital
Address: 2826-36 West Foster Avenue
Date of Introduction: December 16, 2020
Plan Commission Hearing: September 16, 2021

Final for Publication

ELEVATIONS

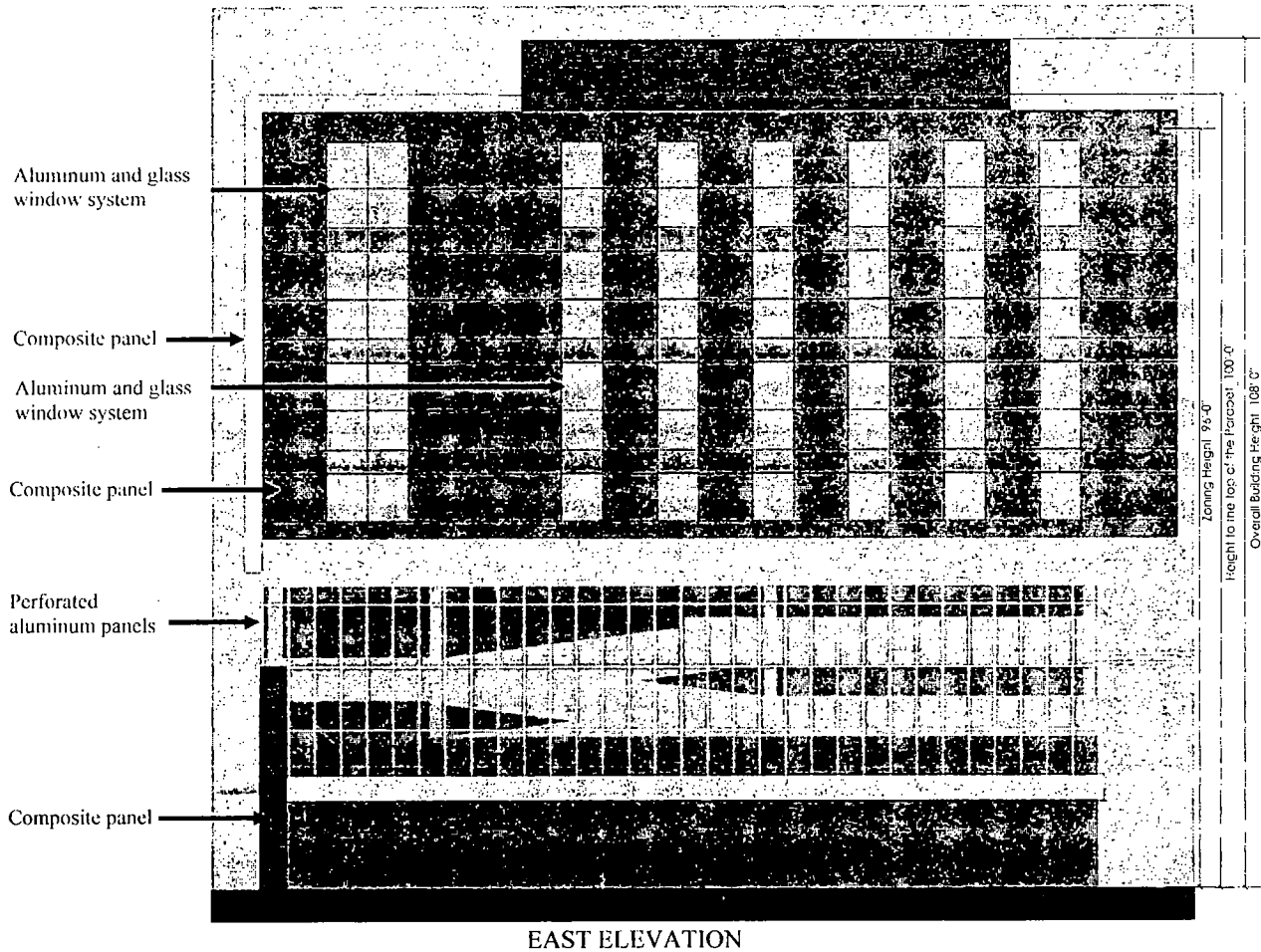

Applicant: Swedish Hospital
Address: 2826-36 West Foster Avenue
Date of Introduction: December 16, 2020
Plan Commission Hearing: September 16, 2021

Final for Publication

ELEVATIONS

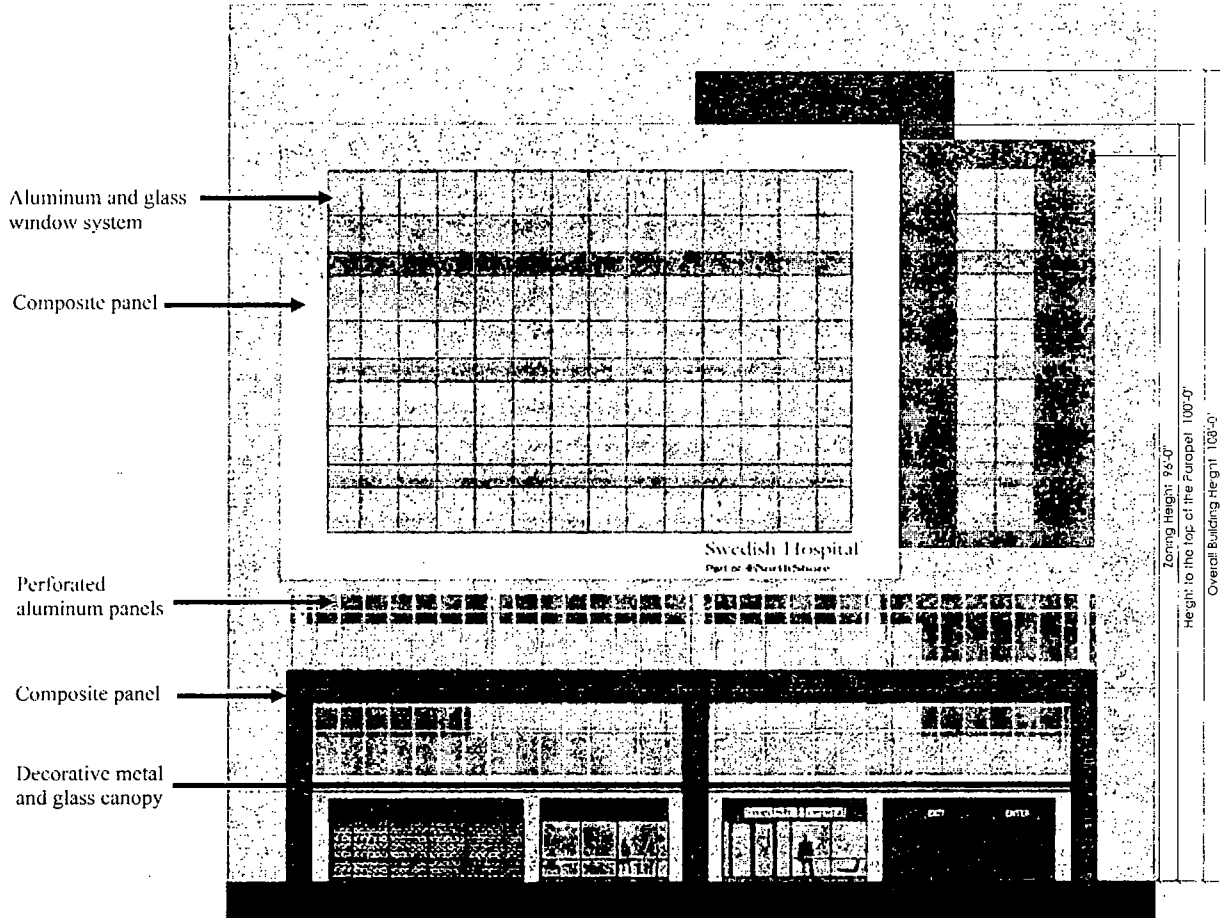

SOUTH ELEVATION

Applicant: Swedish Hospital
Address: 2826-36 West Foster Avenue
Date of Introduction: December 16, 2020
Plan Commission Hearing: September 16, 2021

Final for Publication



ELEVATIONS

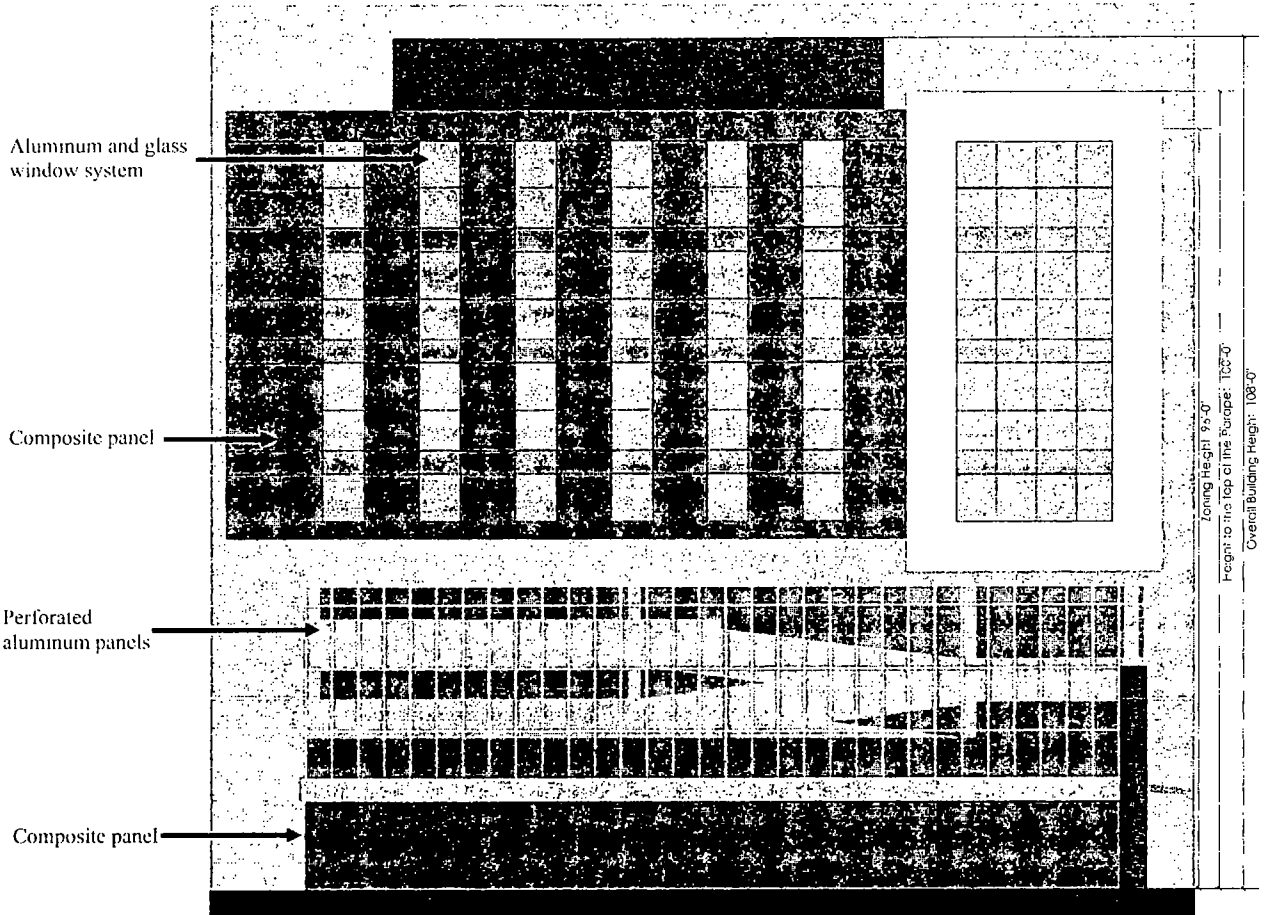

WEST ELEVATION

Applicant: Swedish Hospital
Address: 2826-36 West Foster Avenue
Date of Introduction: December 16, 2020
Plan Commission Hearing: September 16, 2021

Final for Publication



DEPARTMENT OF PLANNING AND DEVELOPMENT
CITY OF CHICAGO

MEMORANDUM

To: Alderman Thomas Tunney
Chairman, City Council Committee on Zoning

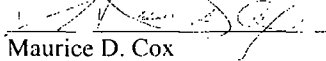
From: 
Maurice D. Cox
Chicago Plan Commission

Date: September 16, 2021

Re: Proposed Amendment to Residential Institutional Planned Development 92

On September 16, 2021, the Chicago Plan Commission recommended approval of an amendment to the planned development submitted by Swedish Covenant Health dba Swedish Hospital. A copy of the proposed planned development amendment is attached. I would very much appreciate your assistance in having this introduced at the next possible City Council Committee on Zoning.

Also enclosed is a copy of the staff report to the Plan Commission which includes the Department of Planning and Development recommendation and a copy of the resolution. If you have any questions in this regard, please do not hesitate to contact me at 312-742-9442.

Cc: Steve Valenziano
PD Master File (Original PD, copy of memo)